

SERVICE MANUAL

MODEL

PVM-9L2

DEST.

WORLD

CHASSIS NO.

SCC-M04C-A

MODEL

DEST.

CHASSIS NO.

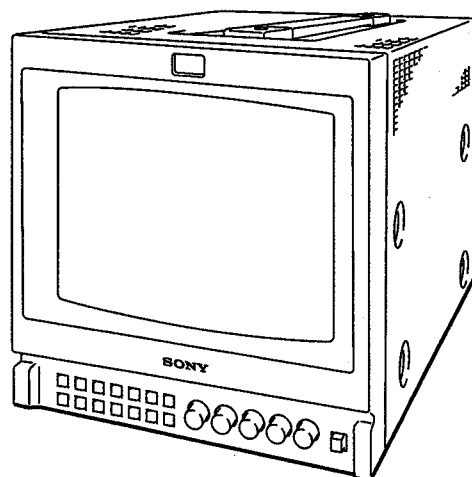

TRINITRON® COLOR VIDEO MONITOR

SONY®

⚠ 警告

このマニュアルは、サービス専用です。

お客様が、このマニュアルに記載された設置や保守、点検、修理などを行うと感電や火災、人身事故につながる可能性があります。

危険をさけるため、サービストレーニングを受けた技術者のみご使用ください。

⚠ WARNING

This manual is intended for qualified service personnel only.

To reduce the risk of electric shock, fire or injury, do not perform any servicing other than that contained in the operating instructions unless you are qualified to do so. Refer all servicing to qualified service personnel.

⚠ WARNUNG

Die Anleitung ist nur für qualifiziertes Fachpersonal bestimmt.

Alle Wartungsarbeiten dürfen nur von qualifiziertem Fachpersonal ausgeführt werden. Um die Gefahr eines elektrischen Schlages, Feuergefahr und Verletzungen zu vermeiden, sind bei Wartungsarbeiten strikt die Angaben in der Anleitung zu befolgen. Andere als die angegebenen Wartungsarbeiten dürfen nur von Personen ausgeführt werden, die eine spezielle Befähigung dazu besitzen.

⚠ AVERTISSEMENT

Ce manuel est destiné uniquement aux personnes compétentes en charge de l'entretien. Afin de réduire les risques de décharge électrique, d'incendie ou de blessure n'effectuer que les réparations indiquées dans le mode d'emploi à moins d'être qualifié pour en effectuer d'autres. Pour toute réparation faire appel à une personne compétente uniquement.

WARNING!!

AN INSULATED TRANSFORMER SHOULD BE USED DURING ANY SERVICE TO AVOID POSSIBLE SHOCK HAZARD, BECAUSE OF LIVE CHASSIS. THE CHASSIS OF THIS RECEIVER IS DIRECTLY CONNECTED TO THE AC POWER LINE.

SAFETY-RELATED COMPONENT WARNING !!

COMPONENTS IDENTIFIED BY A **⚠** MARK ON THE SCHEMATIC DIAGRAMS, EXPLODED VIEWS AND IN THE PARTS LIST ARE CRITICAL TO SAFE OPERATION. REPLACE THESE COMPONENTS WITH SONY PARTS WHOSE PART NUMBERS APPEAR AS SHOWN IN THIS MANUAL OR IN SUPPLEMENTS PUBLISHED BY SONY. CIRCUIT ADJUSTMENTS THAT ARE CRITICAL TO SAFE OPERATION ARE IDENTIFIED IN THIS MANUAL. FOLLOW THESE PROCEDURES WHENEVER CRITICAL COMPONENTS ARE REPLACED OR IMPROPER OPERATION IS SUSPECTED.

ATTENTION!!

AFIN D'ÉVITER TOUT RISQUE D'ÉLECTROCUTION PROVENANT D'UN CHÂSSIS SOUS TENSION, UN TRANSFORMATEUR D'ISOLEMENT DOIT ÊTRE UTILISÉ LORS DE TOUT DÉPANNAGE. LE CHÂSSIS DE CE RÉCEPTEUR EST DIRECTEMENT RACCORDÉ À L'ALIMENTATION SECTEUR.

ATTENTION AUX COMPOSANTS RELATIFS À LA SÉCURITÉ!!

LES COMPOSANTS IDENTIFIÉS PAR UNE MARQUE **⚠** SUR LES SCHÉMAS DE PRINCIPE, LES VUES EXPLOSÉES ET LES LISTES DE PIÈCES SONT D'UNE IMPORTANCE CRITIQUE POUR LA SÉCURITÉ DU FONCTIONNEMENT. NE LES REMPLACER QUE PAR DES COMPOSANTS SONY DONT LE NUMÉRO DE PIÈCE EST INDIQUÉ DANS LE PRÉSENT MANUEL OU DANS DES SUPPLÉMENTS PUBLIÉS PAR SONY. LES RÉGLAGES DE CIRCUIT DONT L'IMPORTANCE EST CRITIQUE POUR LA SÉCURITÉ DU FONCTIONNEMENT SONT IDENTIFIÉS DANS LE PRÉSENT MANUEL. SUIVRE CES PROCÉDURES LORS DE CHAQUE REMPLACEMENT DE COMPOSANTS CRITIQUES, OU LORSQU'UN MAUVAIS FONCTIONNEMENT EST SUSPECTÉ.

Table of Contents

1. Service Informations

1-1.	Board Layout	1-1
1-2.	Disassembly	1-2
1-2-1.	Cabinet Assy Removal	1-2
1-2-2.	Q Board Removal	1-2
1-2-3.	B Board Removal	1-3
1-2-4.	D Board Removal	1-4
1-2-5.	C Board Removal	1-5
1-2-6.	P Board Removal	1-5
1-2-7.	Rear Assy Removal	1-6
1-2-8.	AC Inlet Removal	1-6
1-2-9.	G Block Assy Removal	1-7
1-2-10.	G Board Removal	1-7
1-2-11.	Bezel Complete Assy Removal	1-8
1-2-12.	J Board Removal	1-8
1-2-13.	H Board Removal	1-9
1-2-14.	Deflection Yoke Removal	1-9
1-2-15.	Picture Tube Removal	1-10
1-2-16.	Removal of Anode Cap	1-10
1-2-17.	Bezel Assy and X Board Removal	1-11

2. Set-up Adjustment

2-1.	Equipment Required	2-1
2-2.	Preparations (1)	2-1
2-3.	Preparation (2). Initialization	2-12
2-4.	Writing Model Data	2-12
2-5.	Picture Output	2-12
2-6.	Free-run Frequency Adjustment	2-12
2-7.	Landing Adjustment	2-13
2-8.	H Blanking Adjustment	2-14
2-9.	Deflection Adjustment	2-15
2-10.	Convergence Adjustment (1)	2-16
2-11.	Deflection Yoke Neck Rotation Adjustment	2-17
2-12.	Convergence Adjustment (2)	2-18
2-13.	G2 Adjustment	2-18
2-14.	White Balance Adjustment (15k)	2-19
2-15.	SUB BRIGHT, SUB CONTRAST Adjustment	2-19

2-16.	White Balance Interference Correction Adjustment	2-20
2-16-1.	NTSC Composite Adjustment	2-20
2-16-2.	PAL Composite Adjustment	2-20
2-16-3.	COMPONENT Adjustment	2-20
2-16-4.	SDI Adjustment	2-20
2-17.	Focus Adjustment	2-21
2-18.	V BLK Adjustment	2-21

3. Safety Related Adjustment

3-1.	+B Voltage Check	3-1
3-2.	Hold-down Circuit Connection Check	3-1
3-3.	Protection Circuit Confirmation	3-2
3-3-1.	HV Protector Circuit Confirmation	3-2
3-3-2.	IK Protector Circuit Check	3-2

4. Electrical Adjustments

4-1.	Equipment Required	4-1
4-2.	B Board Adjustments	4-2
4-2-1.	Preparations	4-2
4-2-2.	NTSC SETUP 0 Mode Adjustment	4-3
4-2-2-1.	Y/C Input	4-3
4-2-2-2.	Composite Input	4-4
4-2-3.	NTSC SETUP 7.5 Mode Adjustment	4-4
4-2-3-1.	Y/C Input	4-4
4-2-3-2.	Composite Input	4-4
4-2-4.	PAL Mode Adjustment	4-5
4-2-4-1.	Y/C Input	4-5
4-2-4-2.	Composite Input	4-5
4-2-5.	Y PBPR SMPTE (601) Signal Adjustment	4-6
4-2-6.	Y PBPR BETACAM SETUP 0 Signal Adjustment	4-6
4-2-7.	Y PBPR BETACAM SETUP 7.5 Signal Adjustment	4-7

5. Theory of Operation

5-1.	D Board and P Board	5-1
5-2.	G Board	5-2

6. Semiconductors..... 6-1

7. Spare Parts

7-1. Notes on Repair Parts	7-1
7-2. Exploded Views	7-2
7-3. Electrical Parts List	7-8

8. Block Diagrams

B (1/3), Q (1/2), D(1/2)	8-1
B (2/3), C, H (1/2)	8-2
B (3/3), H (2/2), Q (2/2), X	8-3
G, D (2/2), P, J, DY	8-4

9. Diagrams

9-1. Schematic Diagrams and Printed Wiring Boards	9-2
Schematic Diagrams	
Q	9-3
B (1/5)	9-6
B (2/5)	9-7
B (3/5)	9-8
B (4/5)	9-9
B (5/5)	9-10
H	9-13
P	9-15
C	9-17
J	9-17
D (1/2)	9-20
D (2/2)	9-21
G	9-23
Printed Wiring Boards	
Q	9-2
B	9-4
X	9-5
H	9-13
P	9-14
C	9-16
J	9-16
D	9-18
G	9-24



Section 1

Service Informations

1-1. Board Layout

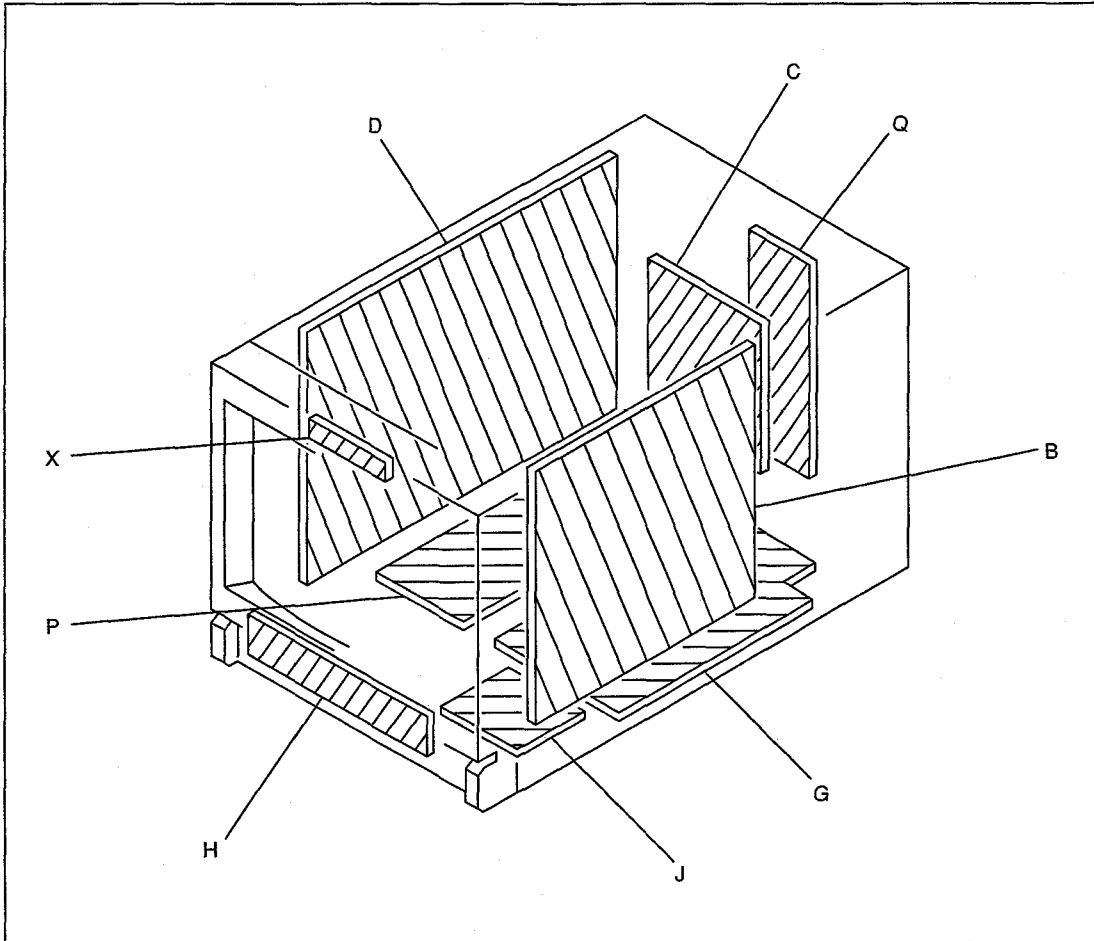

1-2. Disassembly

1-2-1. Cabinet Assy Removal

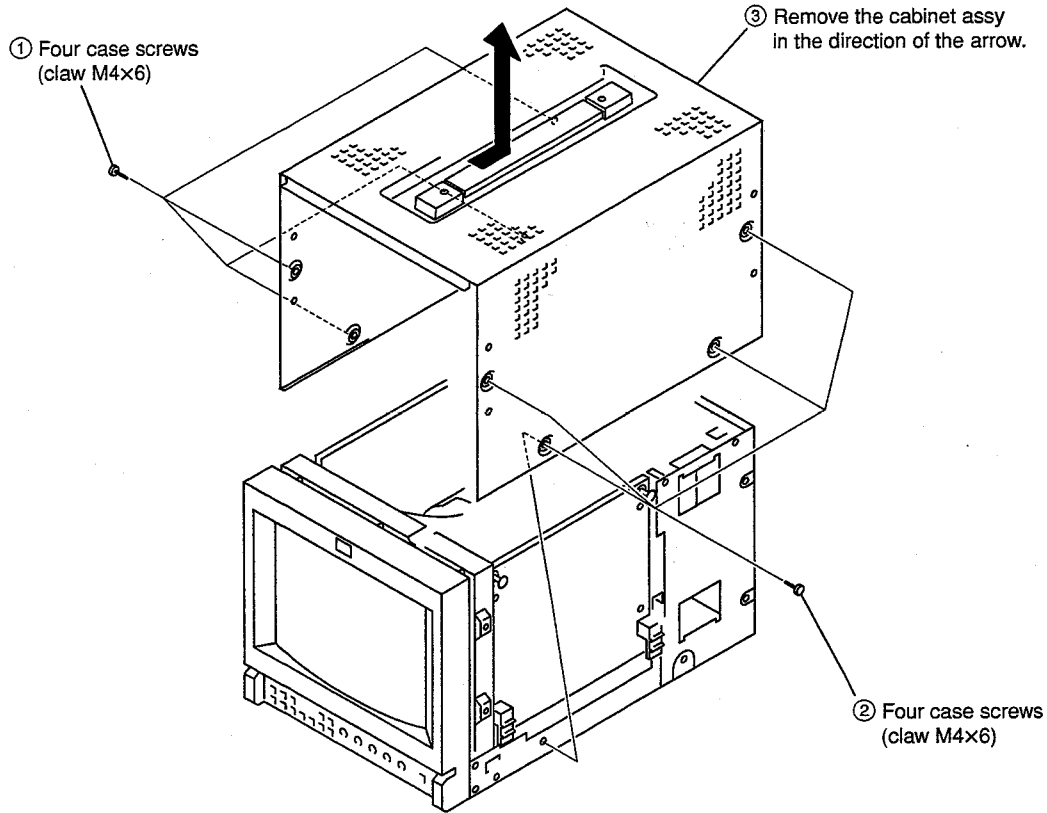

1-2-2. Q Board Removal

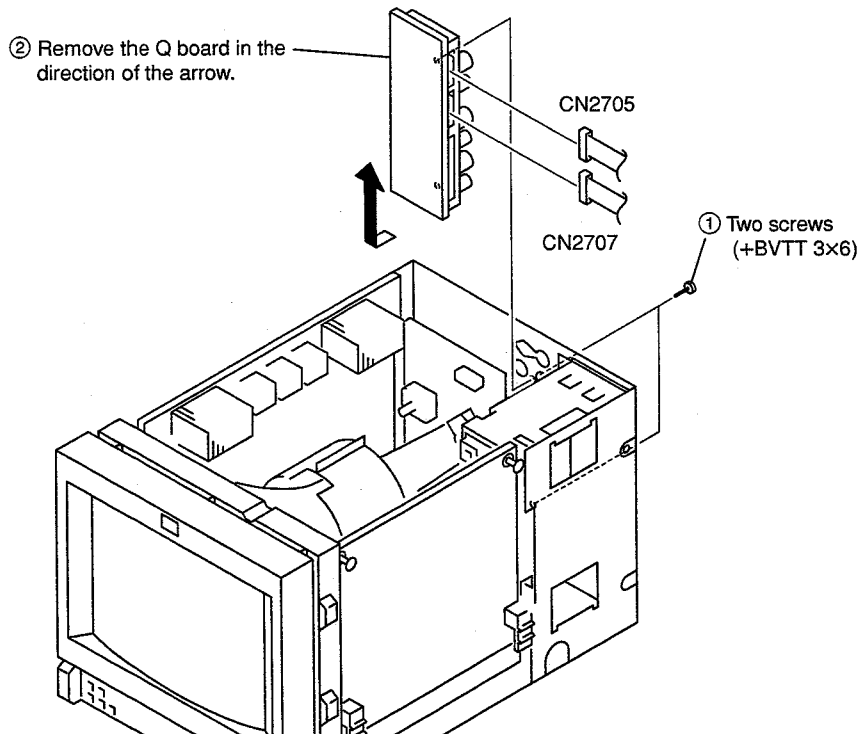

1-2-3. B Board Removal

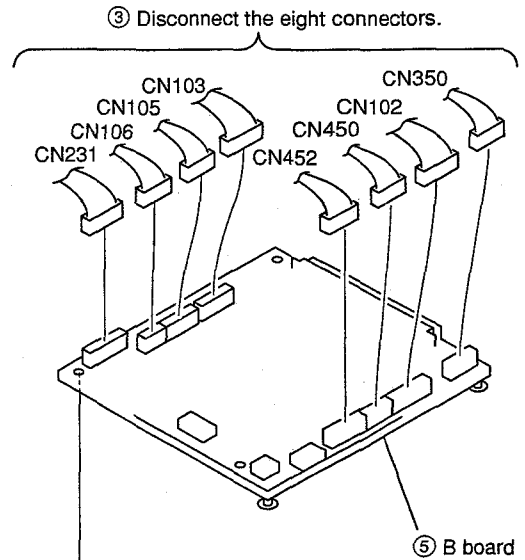
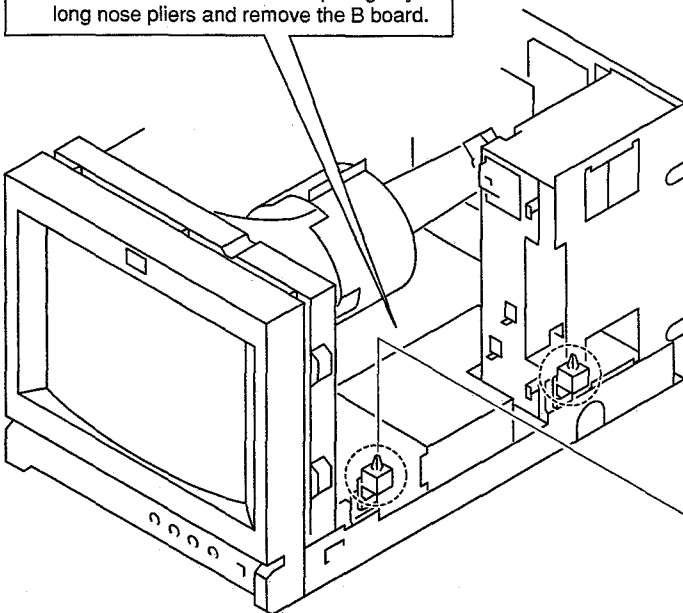
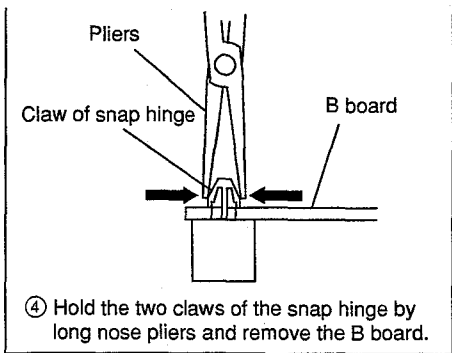
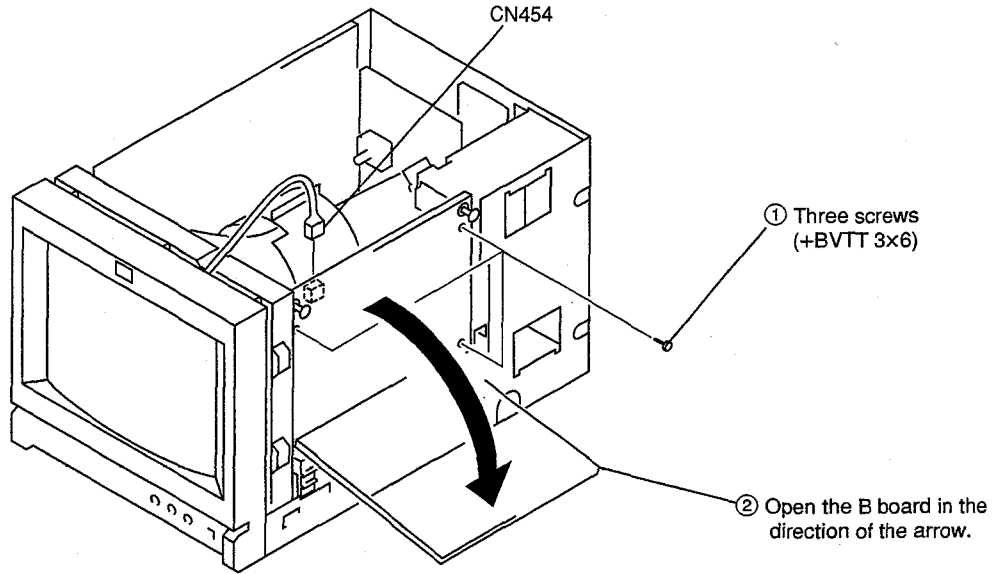

1-2-4. D Board Removal

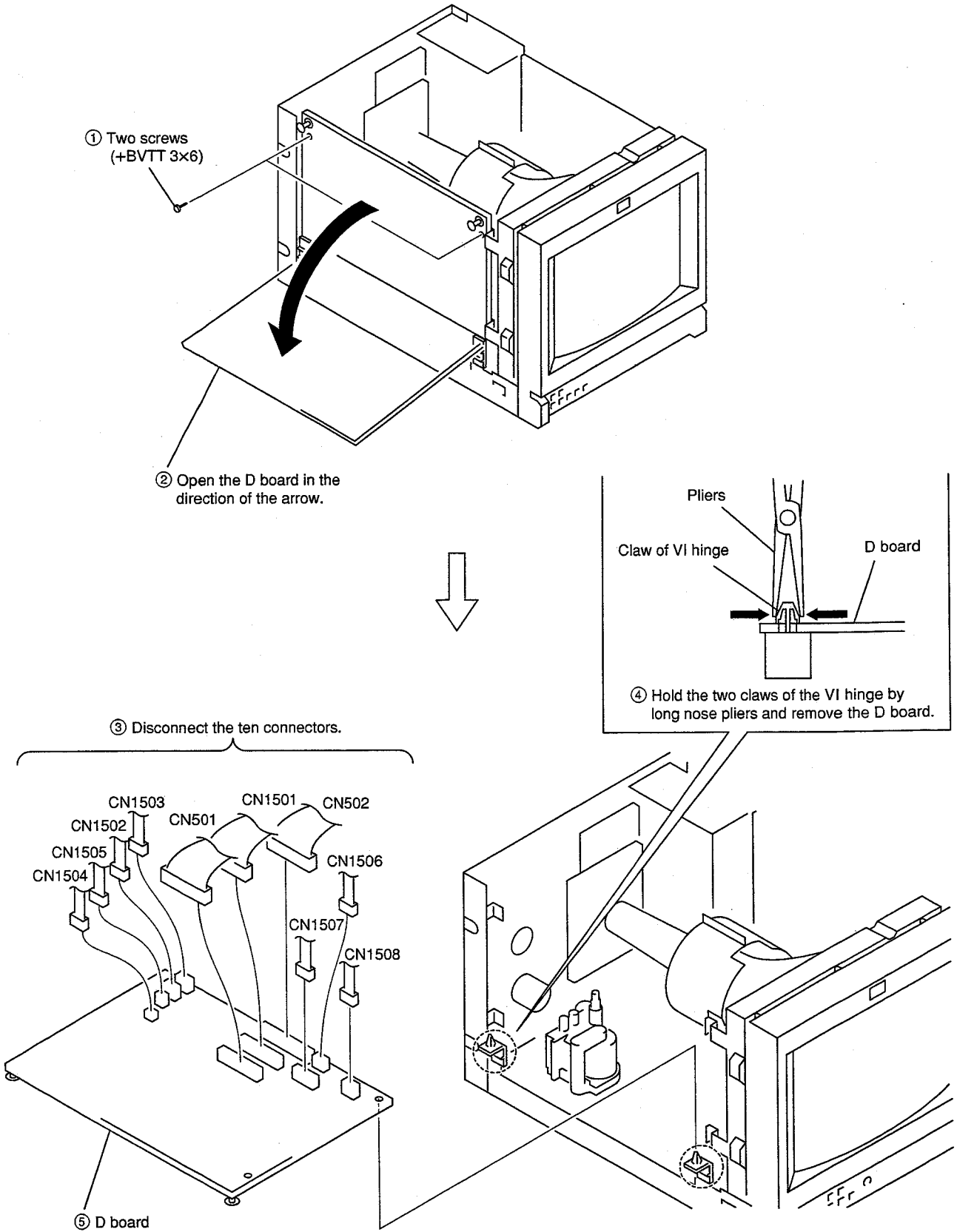

1-2-5. C Board Removal

* Open the D board before proceeding to the next step.

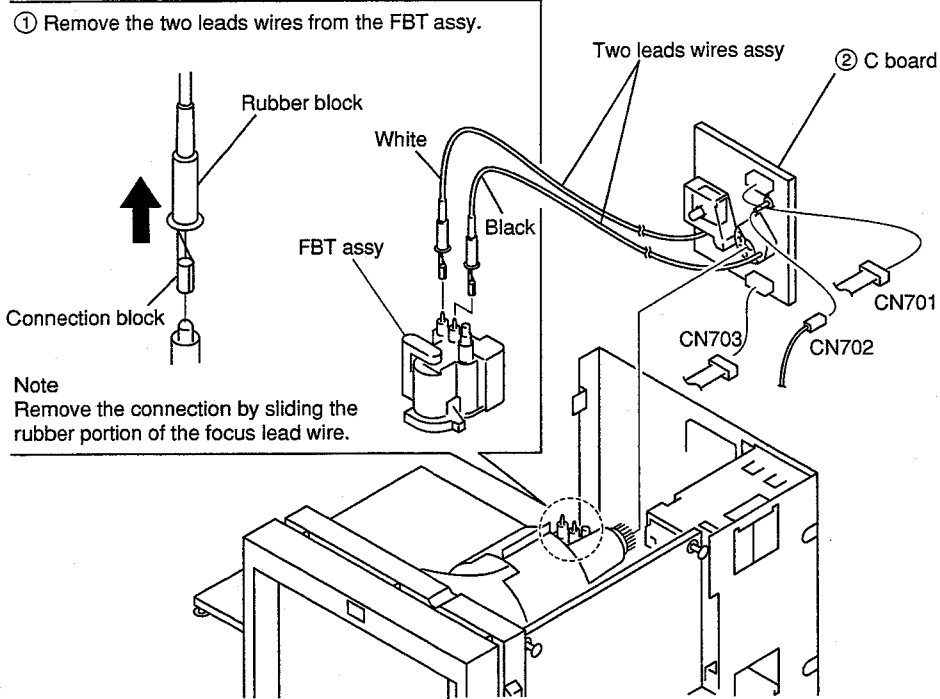

1-2-6. P Board Removal

* Open the D board before proceeding to the next step.

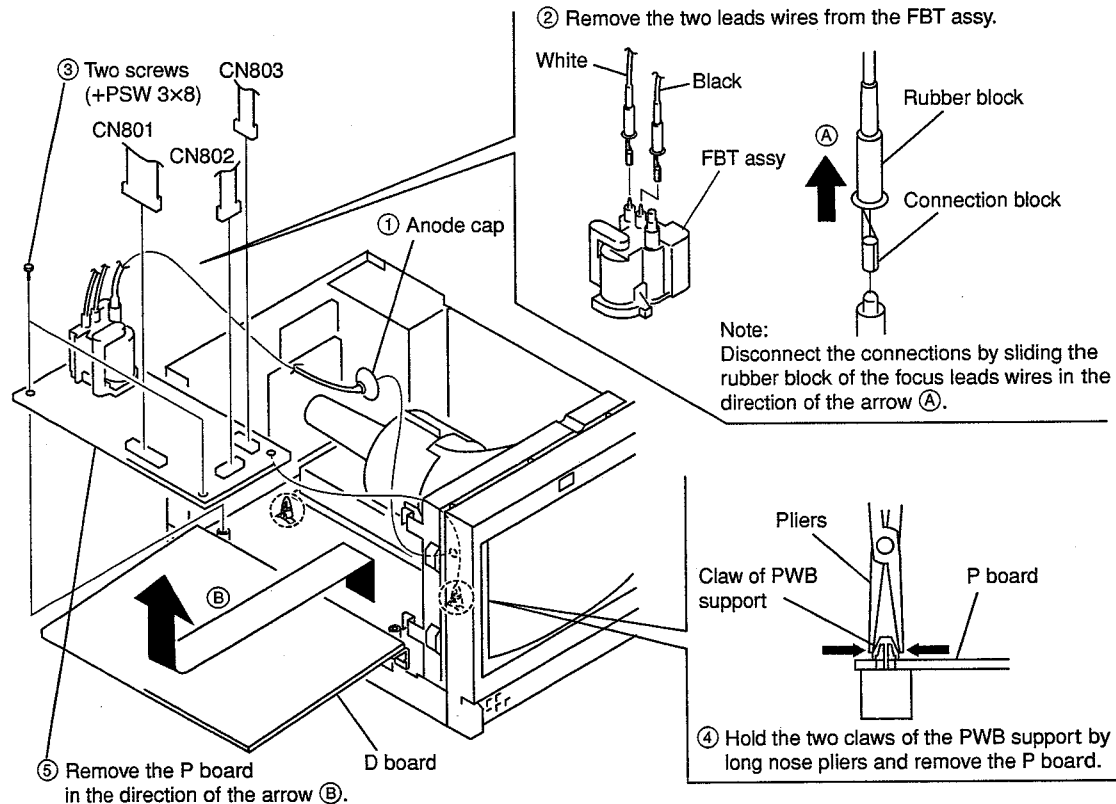

1-2-7. Rear Assy Removal

* Open the B and D boards before Proceeding to the next step.

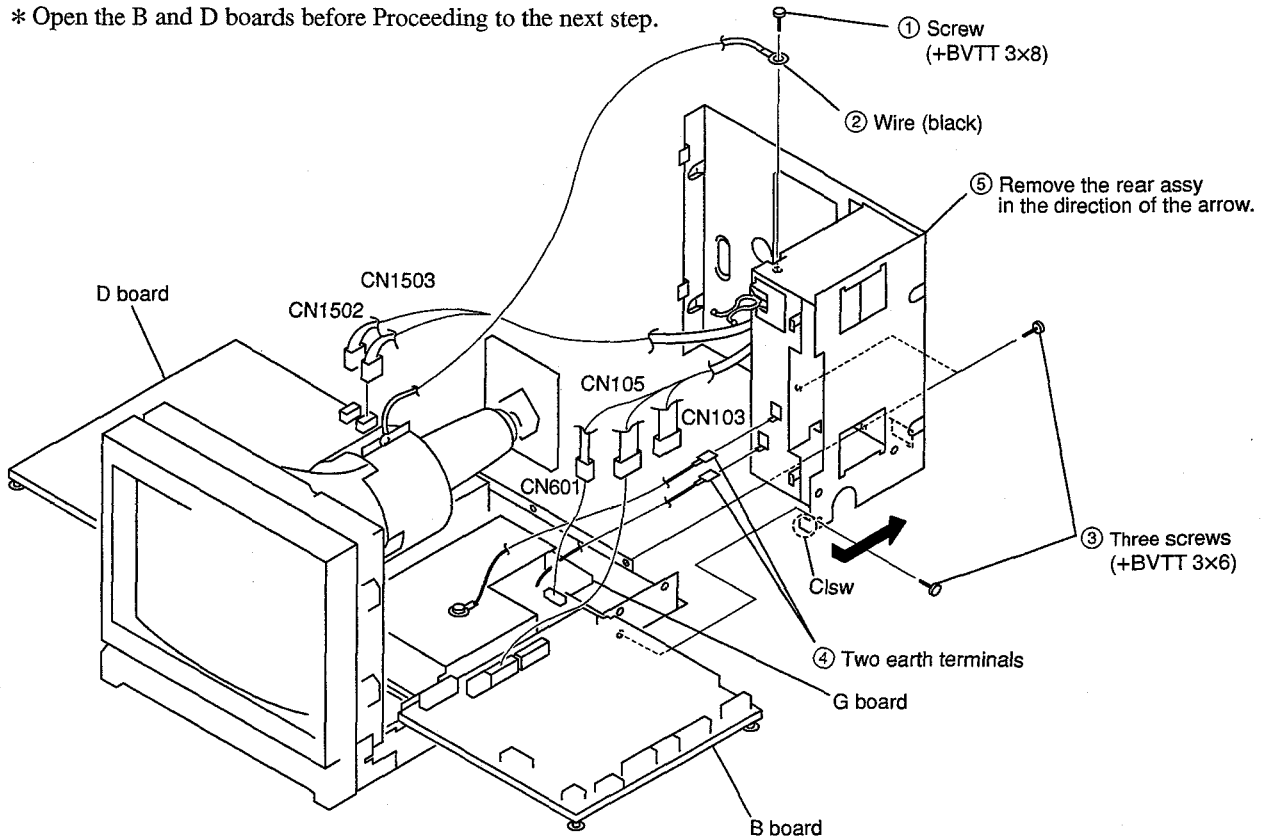

1-2-8. AC Inlet Removal

* Remove the rear assy before removing the AC inlet.

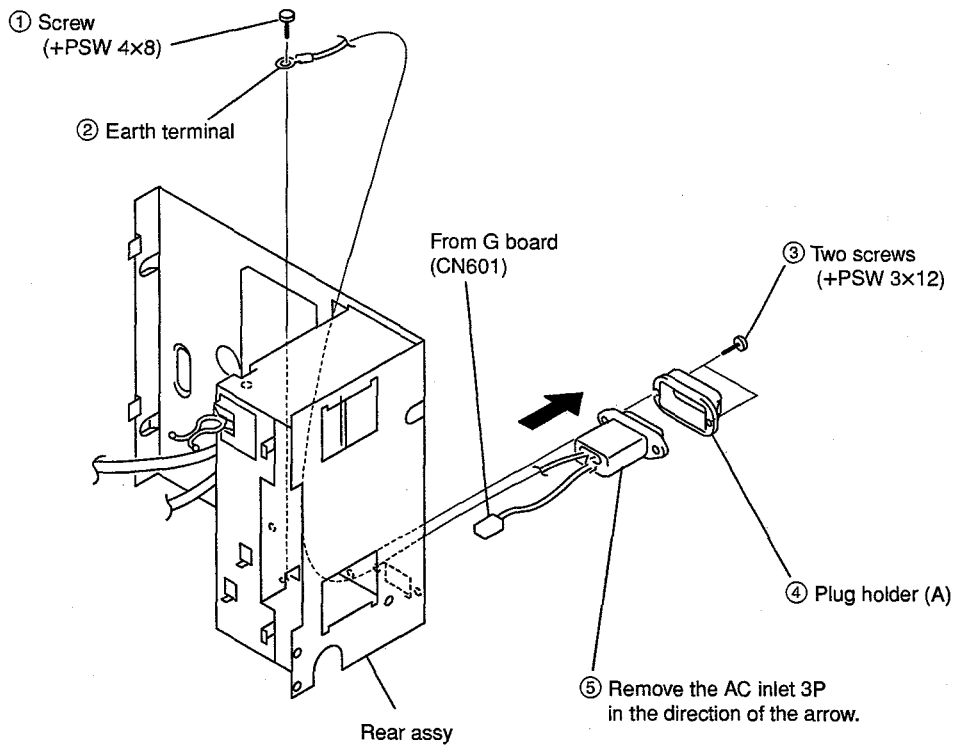

1-2-9. G Block Assy Removal

* Open the B and D boards then remove the rear assy before proceeding to the next step.

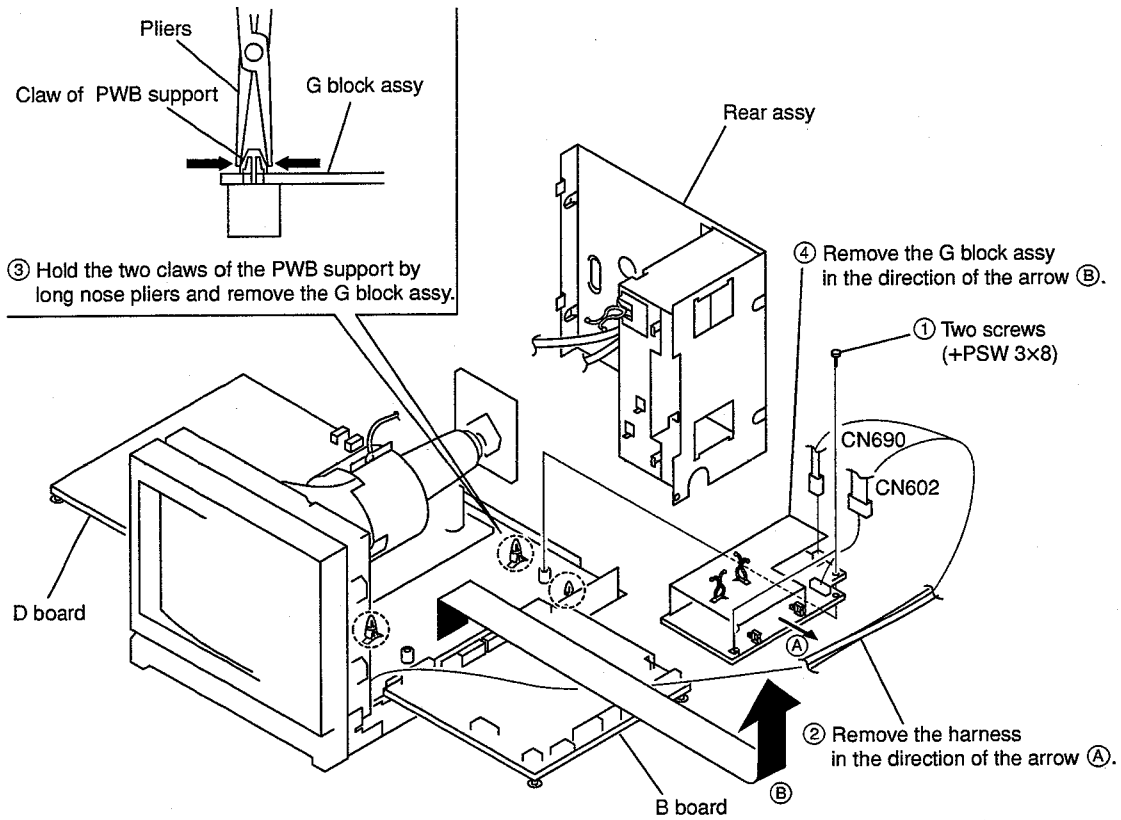

1-2-10. G Board Removal

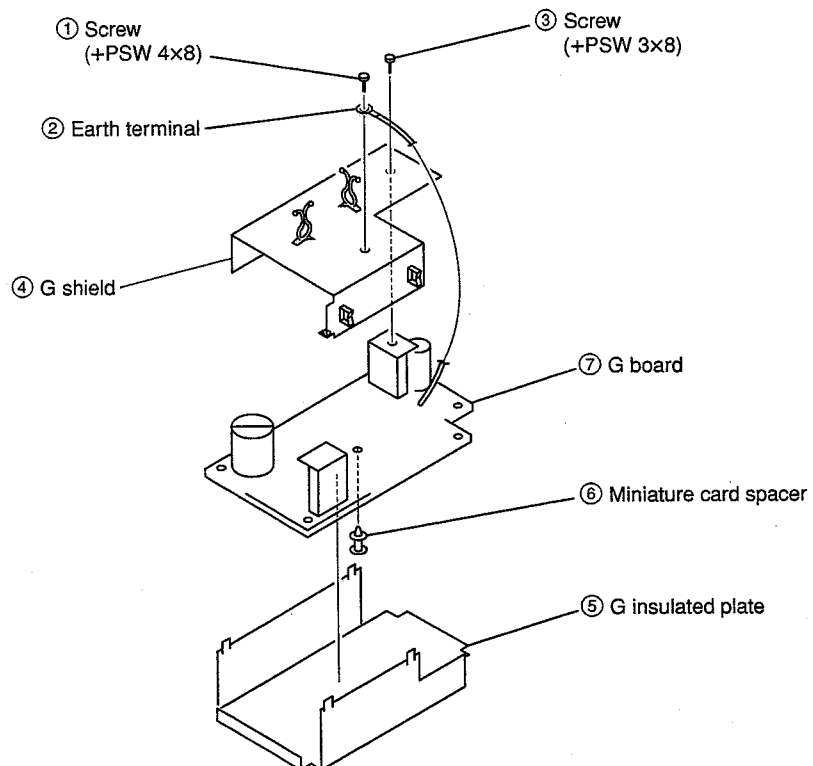

1-2-11. Bezel Complete Assy Removal

* Open the B and D boards then remove the C board before proceeding to the next step.

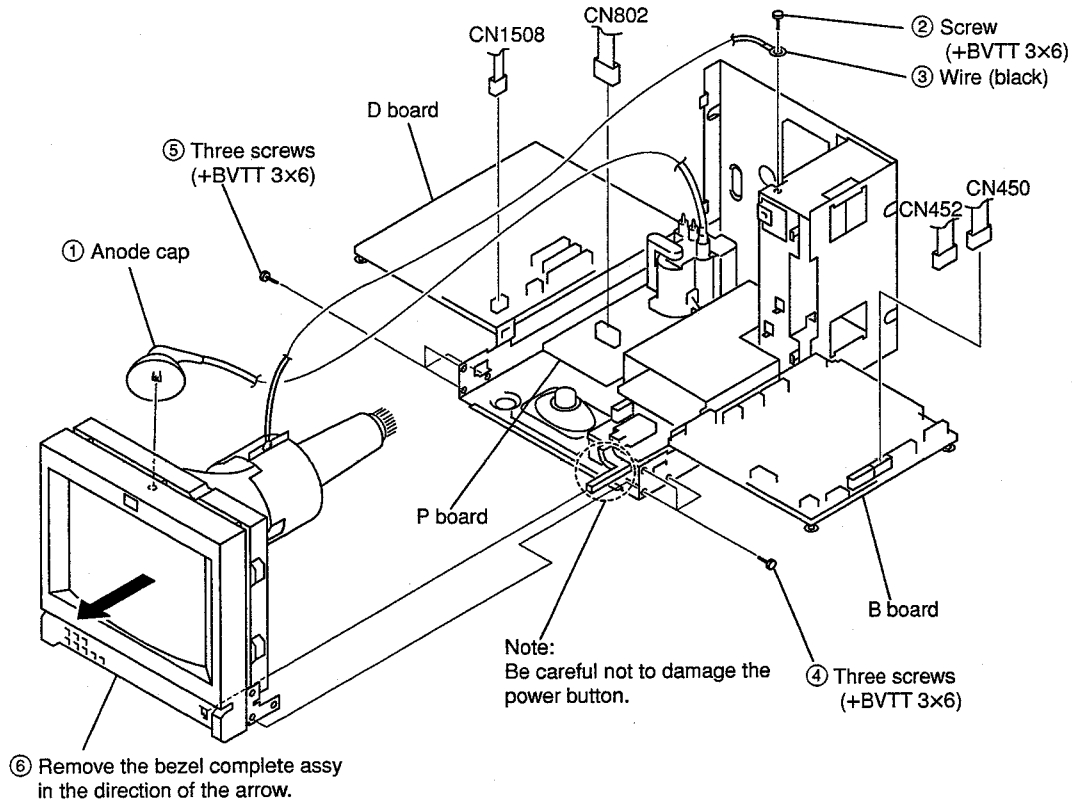

1-2-12. J Board Removal

* Remove the front assy and Picture tube before removing J board.

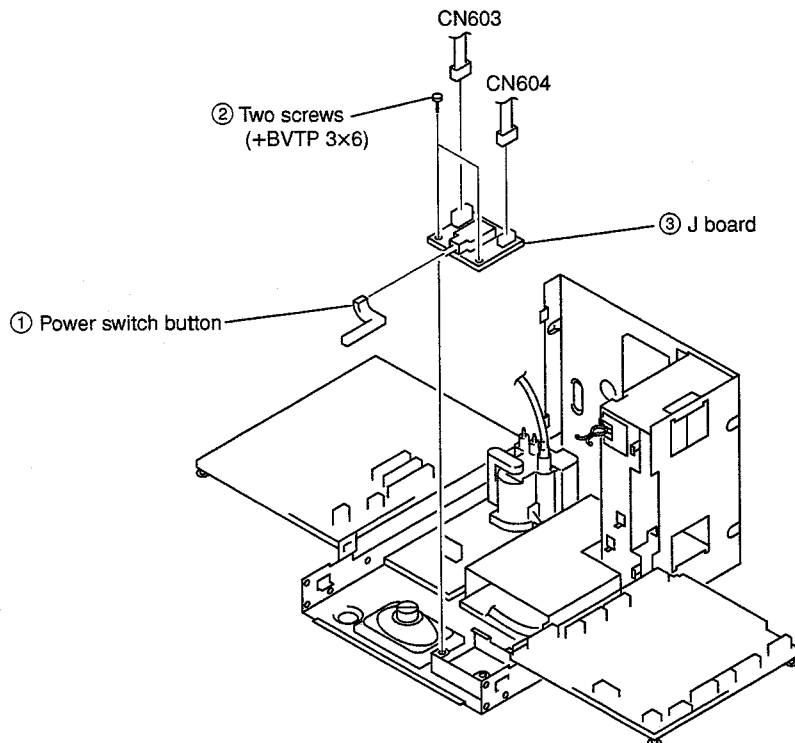

1-2-13. H Board Removal

* Remove the C board and bezel complete assy before removing the H board.

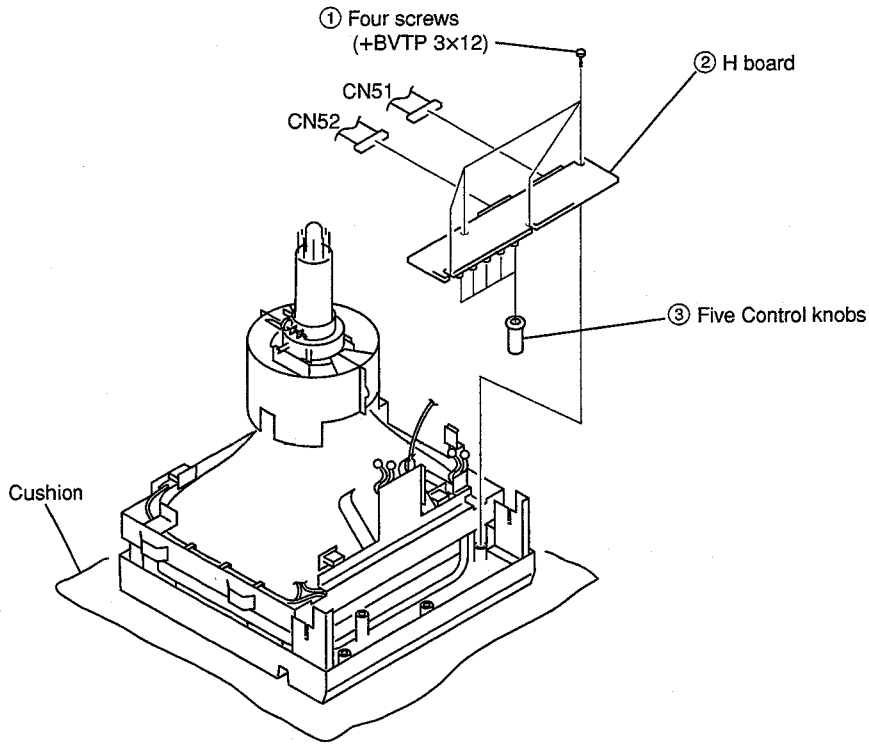

1-2-14. Deflection Yoke Removal

* Remove the C board and bezel complete assy before removing the deflection yoke.

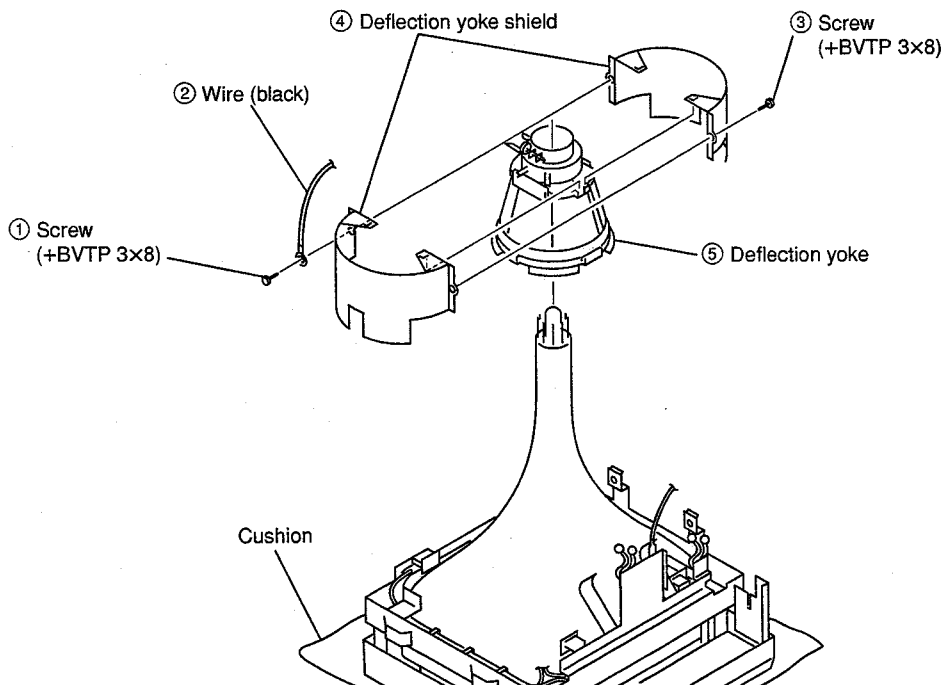

1-2-15. Picture Tube Removal

* Remove C board, bezel complete assy and deflection yoke before removing the picture tube.

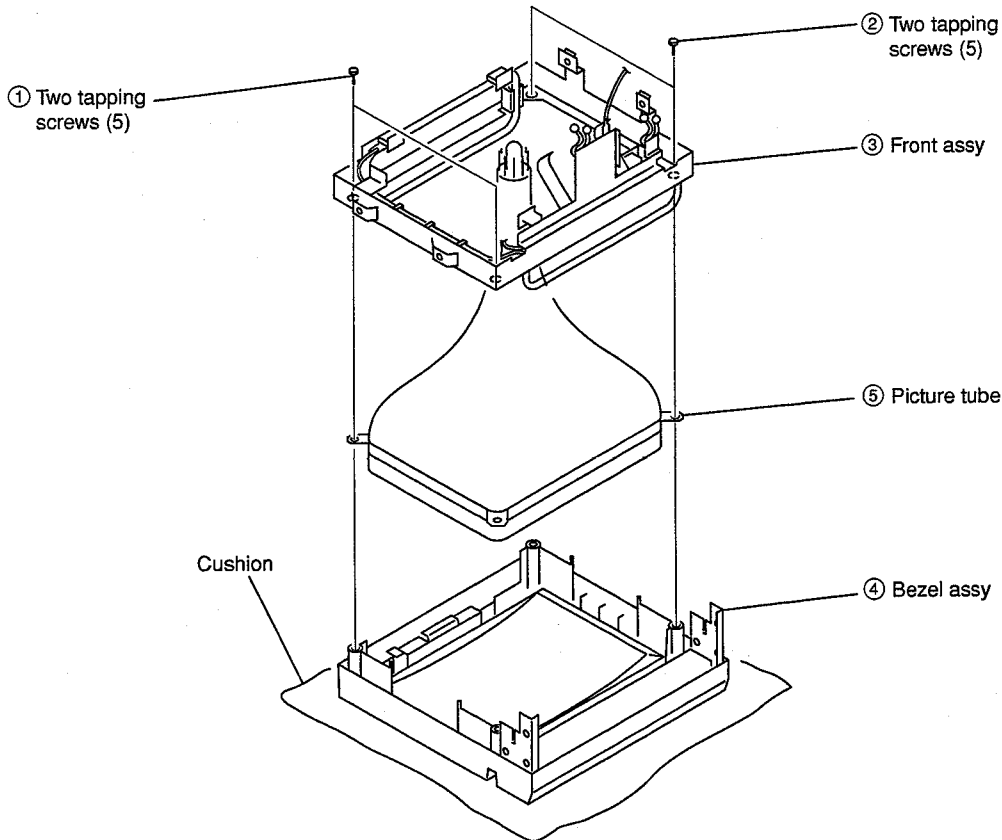

1-2-16. Removal of Anode Cap

Note

Short-circuit the anode of the picture tube and the anode cap to the metal chassis, picture tube shield or carbon painted on the picture tube, after removing the anode.

• Removal Procedure

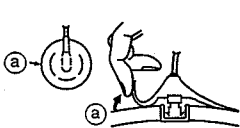

(1) Turn up one side of the rubber cap in the direction indicated by arrow (a).

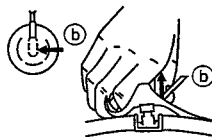

(2) Using a thumb, pull up the rubber cap firmly in the direction indicated by arrow (b).

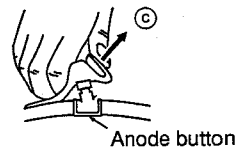

(3) When one side of the rubber cap is separated from the anode button, the anode-cap can be removed by turning up the rubber cap and pulling up it in the direction of the arrow (c).

• Handling Precautions

- (1) Do not scratch the surface of anode cap with a sharp object.
- (2) Do not press the rubber so hard that it damages the inside of anode caps. A shatter-hook terminal is built into the rubber.
- (3) Do not turn the foot of the rubber over. The shatter-hook terminal will stick out or damage the rubber.

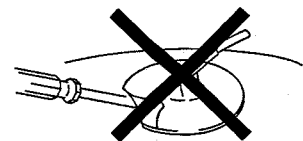
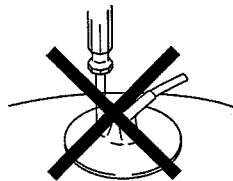

1-2-17. Bezel Assy and X Board Removal

* Remove the front assy and picture tube before removing the bezel assy and X board.

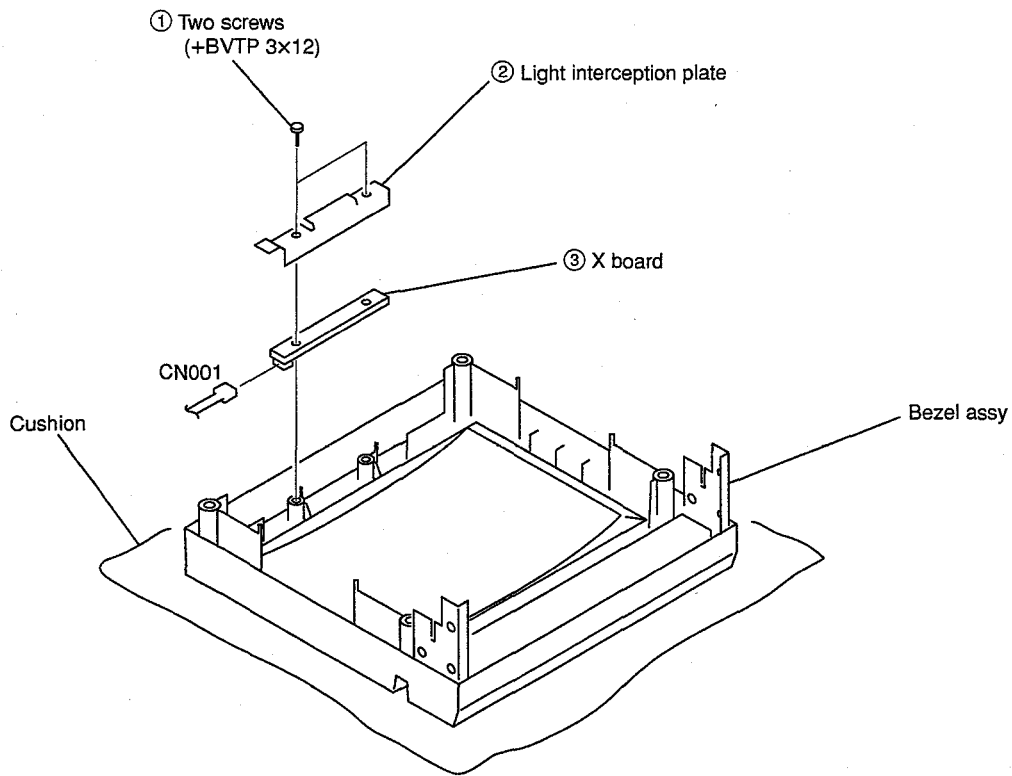

Section 2

Set-up Adjustment

2-1. Equipment Required

- Oscilloscope
Tektronix 2465 or equivalent (with bandwidth of 350 MHz)
- NTSC/PAL component signal generator
Tektronix TG2000 +AVG1 (option module)
+AWVG1 (option module) or equivalent
- SDI signal generator
Tektronix TSG-422
- Monoscope signal generator
ShibaSoku TP22AX or equivalent
- VG (programmable video signal generator)
VG854 or equivalent
- Frequency counter
Advantest TR5821AK or equivalent
- Digital VOM
Advantest TR6845 or equivalent
- Slide induction transformer
- High tension voltmeter
- DC power supply
- Ammeter
- Luminance meter
Minolta CA-100 or equivalent.
If the Minolta CA-100 is not available, perform the measurement by visual inspection by comparing the monitor that has already been adjusted earlier with the monitor that you want to adjust.

Note

Start the following adjustments 5 minutes after the main power is turned on.

* In this chapter, indicates the control items in the service mode.

Example : 60 H-FREQ

2-2. Preparations (1)

Service Mode

This set is provided with a switch for service on the front panel that can be used to make various adjustments. The operation method of this switch is explained in detail below.

1. Entering the service mode
Simultaneously press the [ENTER] key and the [DEGAUSS] key shown on the display of the menu.

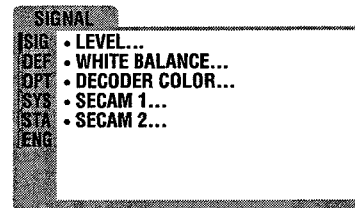

2. Operating the Service Mode
Select the desired service item with the [↑], [↓] key and press the [ENTER] key to enter the adjustment mode.
Press the [↑] key to increase the adjustment value.
Press the [↓] key to decrease the adjustment value.
Press the [ENTER] key to save the adjustment value.
Press the [MENU] key to cancel the entry.
3. Finishing the service mode
Simultaneously press the [ENTER] key and the [DEGAUSS] key shown on the display of the menu.
4. Easy ON/OFF of the service mode
If once entering the service mode after having turned on the power, easy ON/OFF is possible by once more pressing the LINE A, LINE B, OPTION A or OPTION B switch on the front panel (the LED lights) as long as the power is not turned off or as long as the service mode is not finished.

Service Mode screen display

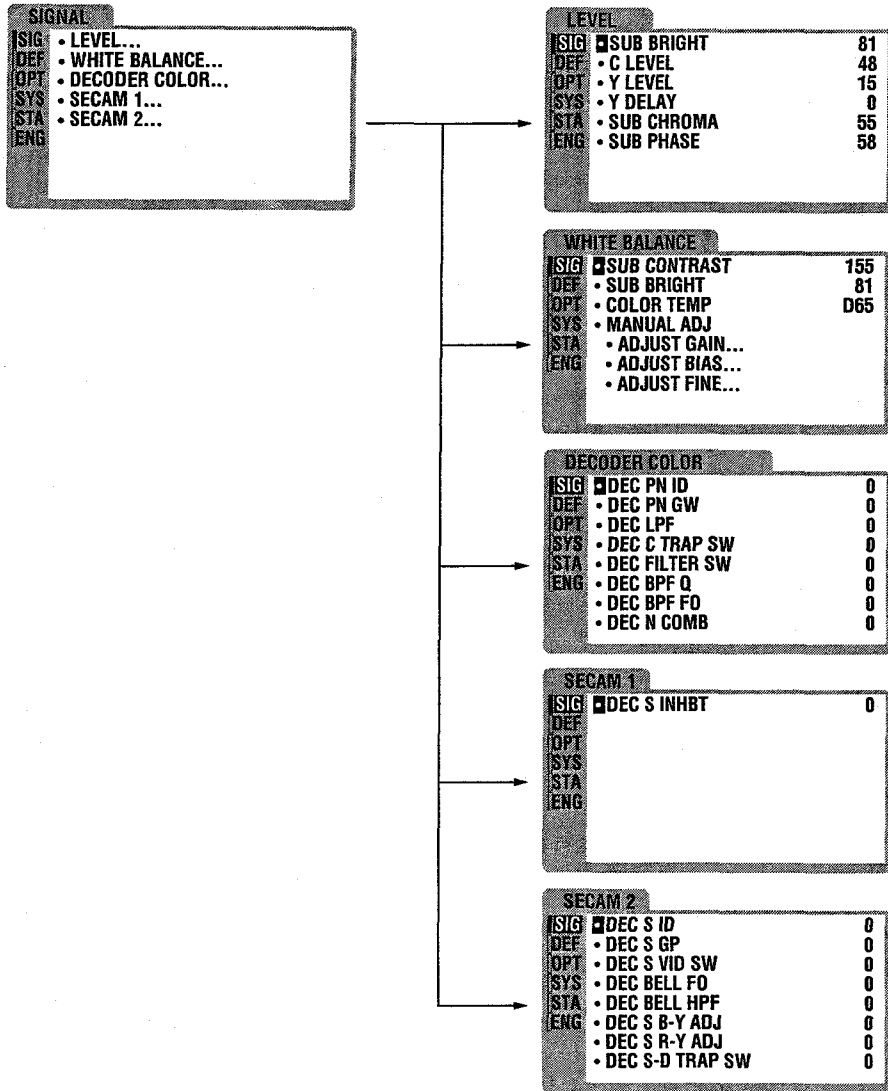

SYSTEM		
SIG	VERSION	1.0
DEF	• MODEL INCH	14
OPT	• MODEL TYPE	J
SYS	• AGING MODE	
STA	• FACTORY...	
ENG	• SIGNAL...	
	• MAINTENANCE ID	0
	• SETUP...	

AGING MODE

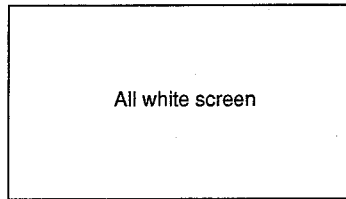

All white screen

To return to the original screen,
press the button of the input selector
illuminating in orange.

SYSTEM		
SIG	VERSION	1.0
DEF	• MODEL INCH	14
OPT	• MODEL TYPE	J
SYS	• AGING MODE	
STA	• FACTORY...	
ENG	• SIGNAL...	
	• MAINTENANCE ID	0
	• SETUP...	

FACTORY

SYSTEM		
SIG	<input checked="" type="checkbox"/> LOAD...	
DEF		
OPT	• STANDARD...	
SYS		
STA		
ENG		

LOAD cannot be selected and remains in the blue display unless the NVM data is valid. In such a case, clear the NVM and make the NVM data valid first. However, if the default factory data is damaged, or if the FACTORY SET process is not executed after ROM is replaced, LOAD cannot be executed. STANDARD returns the various setups of the user menu to the default factory setting.

SIGNAL

SYSTEM		
SIG	<input checked="" type="checkbox"/> COLOR DET.	AUTO
DEF		
OPT		
SYS		
STA		
ENG		

SETUP

SYSTEM		
SIG	<input checked="" type="checkbox"/> CHINESE ENA	OFF
DEF		
OPT		
SYS		
STA		
ENG		

Name	Description	Set memory
VALID	Validity identification byte=h'55	0x55
HFV SENS	Horizontal frequency 15K	27
HFV CONTROL	Horizontal frequency 15K	249
H SIZE	480/60I NORMAL	123
	480/80I UNDER	93
	575/50I NORMAL	120
	575/50I UNDER	90
FORMER H POSITION	Not used (FORMER H POSITION is moved to 0x114)	0
	Not used	0
SIDE PINBAL	480/60I 4:3 NORMAL	14
	480/60I 4:3 UNDER	14
	480/60I 16:9 NORMAL	14
	480/60I 16:9 UNDER	14
	575/50I 4:3 NORMAL	14
	575/50I 4:3 UNDER	14
	575/50I 16:9 NORMAL	14
	575/50I 16:9 UNDER	14
PARA CONTROL	480/60I 4:3 NORMAL	13
	480/60I 4:3 UNDER	13
	480/60I 16:9 NORMAL	14
	480/60I 16:9 UNDER	14
	575/50I 4:3 NORMAL	13
	575/50I 4:3 UNDER	13
	575/50I 16:9 NORMAL	14
	575/50I 16:9 UNDER	14
SIDE PIN W	480/60I 4:3 NORMAL	30
	480/60I 4:3 UNDER	32
	480/60I 16:9 NORMAL	32
	480/60I 16:9 UNDER	32
	575/50I 4:3 NORMAL	33
	575/50I 4:3 UNDER	33
	575/50I 16:9 NORMAL	30
	575/50I 16:9 UNDER	30
SIDE PIN	480/60I 4:3 NORMAL	60
	480/60I 4:3 UNDER	60
	480/60I 16:9 NORMAL	61
	480/60I 16:9 UNDER	61
	575/50I 4:3 NORMAL	59
	575/50I 4:3 UNDER	59
	575/50I 16:9 NORMAL	60
	575/50I 16:9 UNDER	60

Name	Description	Set memory
SIDE PIN S	480/60I 4:3 NORMAL	30
	480/60I 4:3 UNDER	30
	480/60I 16:9 NORMAL	30
	480/60I 16:9 UNDER	30
	575/50I 4:3 NORMAL	30
	575/50I 4:3 UNDER	30
	575/50I 16:9 NORMAL	30
	575/50I 16:9 UNDER	31
TRAPEZOID	480/60I 4:3 NORMAL	30
	480/60I 4:3 UNDER	30
	480/60I 16:9 NORMAL	30
	480/60I 16:9 UNDER	30
	575/50I 4:3 NORMAL	30
	575/50I 4:3 UNDER	30
	575/50I 16:9 NORMAL	30
	575/50I 16:9 UNDER	30
V SIZE	480/60I 4:3 NORMAL	70
	480/60I 4:3 UNDER	15
	480/60I 16:9 NORMAL	66
	480/60I 16:9 UNDER	16
	575/50I 4:3 NORMAL	50
	575/50I 4:3 UNDER	11
	575/50I 16:9 NORMAL	64
	575/50I 16:9 UNDER	18
V CENT	480/60I	180
	575/50I	200
V S LIN	480/60I 4:3 NORMAL	21
	480/60I 4:3 UNDER	22
	480/60I 16:9 NORMAL	27
	480/60I 16:9 UNDER	29
	575/50I 4:3 NORMAL	20
	575/50I 4:3 UNDER	22
	575/50I 16:9 NORMAL	27
	575/50I 16:9 UNDER	30
V C LIN	480/60I 4:3 NORMAL	28
	480/60I 4:3 UNDER	30
	480/60I 16:9 NORMAL	26
	480/60I 16:9 UNDER	27
	575/50I 4:3 NORMAL	31
	575/50I 4:3 UNDER	29
	575/50I 16:9 NORMAL	30
	575/50I 16:9 UNDER	30

Name	Description	Set memory
WB G BIAS L	D65 15K	0
	D93 15K	0
	USER 15K	0
WB G BIAS H	D65 15K	0x64
	D93 15K	0x64
	USER 15K	0x64
WB B GAIN L	D65 15K	0
	D93 15K	0
	USER 15K	0
WB B GAIN H	D65 15K	0xaf
	D93 15K	0xaf
	USER 15K	0xaf
WB B BIAS L	D65 15K	0
	D93 15K	0
	USER 15K	0
WB B BIAS H	D65 15K	0x64
	D93 15K	0x64
	USER 15K	0x64
WB FINE	Other than PAL B : Cb OFFSET 1/R : Cr OFFSET1	0x88
	PAL B : Cb OFFSET 1/R : Cr OFFSET1	0x88
	Other than option boards B : Cb OFFSET 2/R : Cr OFFSET2	0x88
	Option boards B : Cb OFFSET 2/R : Cr OFFSET2	0x88
MODEL INCH	Model Identification Code	0
MODEL TYPE	Model Identification Code	0
SUBCON CONTRAST	SUBCON LINE-A (COMPOSITE)	50
	SUBCON LINE-A (S)	50
	SUBCON LINE-B (COMPOSITE)	50
	Not used (Keep blank for S Extension Input for LINE-B)	255
	SUBCON RGB	50
	SUBCON COMPONENT	50
	SUBCON OPTION-A (Other than 129X)	50
	SUBCON OPTION-B (Other than 129X)	50
	SUBCON OPTION-RGB (129X)	50
SUBCON OPTION-COMPONENT (129X)	50	
SUBCON BRIGHT	SUBCON LINE-A (COMPOSITE)	50
	SUBCON LINE-A (S)	50
	SUBCON LINE-B (COMPOSITE)	50

Name	Description	Set memory
SUBCON BRIGHT	Not used (Keep blank for S Extension Input for LINE-B)	255
	SUBCON RGB	0xb2
	SUBCON COMPONENT	50
	SUBCON OPTION-A (Other than 129X)	50
	SUBCON OPTION-B (Other than 129X)	50
	SUBCON OPTION-RGB (129X)	0xb2
	SUBCON OPTION-COMPONENT (129X)	50
SUBCON CHROMA	SUBCON LINE-A (COMPOSITE)	50
	SUBCON LINE-A (S)	50
	SUBCON LINE-B (COMPOSITE)	50
	Not used (Keep blank for S Extension Input for LINE-B)	255
	SUBCON RGB	50
	SUBCON COMPONENT	50
	SUBCON OPTION-A (Other than 129X)	50
	SUBCON OPTION-B (Other than 129X)	50
	SUBCON OPTION-RGB (129X)	50
	SUBCON OPTION-COMPONENT (129X)	50
SUBCON PHASE	SUBCON LINE-A (COMPOSITE)	50
	SUBCON LINE-A (S)	50
	SUBCON LINE-B (COMPOSITE)	50
	Not used (Keep blank for S Extension Input for LINE-B)	255
	SUBCON RGB	50
	SUBCON COMPONENT	50
	SUBCON OPTION-A (Other than 129X)	50
	SUBCON OPTION-B (Other than 129X)	50
	SUBCON OPTION-RGB (129X)	50
SUBCON OPTION-COMPONENT (129X)	50	
SUBCON APERTURE	SUBCON LINE-A (COMPOSITE)	0
	SUBCON LINE-A (S)	0
	SUBCON LINE-B (COMPOSITE)	0
	Not used (Keep blank for S Extension Input for LINE-B)	255
	SUBCON RGB	0
	SUBCON COMPONENT	0
	SUBCON OPTION-A (Other than 129X)	0
	SUBCON OPTION-B (Other than 129X)	0
	SUBCON OPTION-RGB (129X)	0
SUBCON OPTION-COMPONENT (129X)	0	

Name	Description	Set memory	
FORMER AUTO CHROMA PHASE	NTSC A : AUTO SETUP (0=OFF 1=ON) (Moved to 0x01FD)	0	
	(S)-NTSC A : AUTO SETUP (0=OFF 1=ON)	0	
	NTSC 4.43 A : AUTO SETUP (0=OFF 1=ON)	0	
	(S)-NTSC 4.43 A : AUTO SETUP (0=OFF 1=ON)	0	
	PAL A : AUTO SETUP (0=OFF 1=ON)	0	
	(S)-PAL A : AUTO SETUP (0=OFF 1=ON)	0	
	COMPONENT A : AUTO SETUP (0=OFF 1=ON)	0	
	BKM-129X A : AUTO SETUP (0=OFF 1=ON)	0	
	BKM-120D A : AUTO SETUP (0=OFF 1=ON)	0	
	BKM-150CP A : AUTO SETUP (0=OFF 1=ON)	0	
	BKM-155DV A : AUTO SETUP (0=OFF 1=ON)	0	
	Y LEVEL	NTSC-0	13
		NTSC-7.5	16
NTSC 4.43		10	
PAL		14	
(S)-NTSC-0		14	
(S)-NTSC-7.5		17	
(S)-NTSC 4.43		10	
(S)-PAL		15	
SMPTE/SDI		14	
BETA-0		13	
BETA-7.5		16	
C LEVEL	NTSC	42	
	NTSC 4.43	35	
	PAL	39	
	(S)-NTSC	40	
	(S)-NTSC 4.43	35	
	(S)-PAL	39	
	SMPTE/SDI	47	
	BETA-0	25	
	BETA-7.5	29	

Name	Description	Set memory
SYSTEM SETTINGS 1	System Setup (Step 1) F : Color identification forced mode (0=AUTO 1=NTSC 2=PAL) S : Chinese language is supported (0=OFF 1=ON)	0
SYSTEM SETTINGS 2	System Setup (Step 2)	0
AUTO CHROMA PHASE	NTSC A : AUTO SETUP (0=OFF 1=ON)	0
	(S)-NTSC A : AUTO SETUP (0=OFF 1=ON)	0
	NTSC 4.43 A : AUTO SETUP (0=OFF 1=ON)	0
	(S)-NTSC 4.43 A : AUTO SETUP (0=OFF 1=ON)	0
	PAL A : AUTO SETUP (0=OFF 1=ON)	0
	(S)-PAL A : AUTO SETUP (0=OFF 1=ON)	0
	COMPONENT A : AUTO SETUP (0=OFF 1=ON)	0
	BKM-129X A : AUTO SETUP (0=OFF 1=ON)	0
	BKM-120D A : AUTO SETUP (0=OFF 1=ON)	0
	BKM-150CP A : AUTO SETUP (0=OFF 1=ON)	0
	BKM-155DV A : AUTO SETUP (0=OFF 1=ON)	0

2-7. Landing Adjustment

1. CONTRAST... MAX
BRIGHT... Conspicuous position
2. Roughly adjust the white balance, G2, and convergence.
3. Switch the video signal generator output signal to green only.
4. Adjust the purity knob so that the green will come to the center of the screen. Make R and B almost identical. (Fig. 2-1)
5. Switch to B only, R only, and G only and verify each. (Figs. 2-1, 2-2, and 2-3)
6. Bring the deflection yoke gradually forward and adjust the deflection yoke so that R and B on both sides of the screen will be green. (Fig. 2-2 → Fig. 2-3)
7. If the deflection yoke comes forward too much, the pattern shown in Fig. 2-4 will appear. If so, move the deflection yoke backward. (Fig. 2-4 → Fig. 2-3)
8. Switch the single color switch to B and verify the single color. (Fig. 2-6)
9. Switch the single color switch to R and verify the single color. (Fig. 2-9)
10. When two colors are mixed, set the mixed color as the standard, and repeat steps 6 and 7.
11. Switch to an all-white signal and check the uniformity.
12. When the deflection yoke position is determined, fasten it with the fixture.

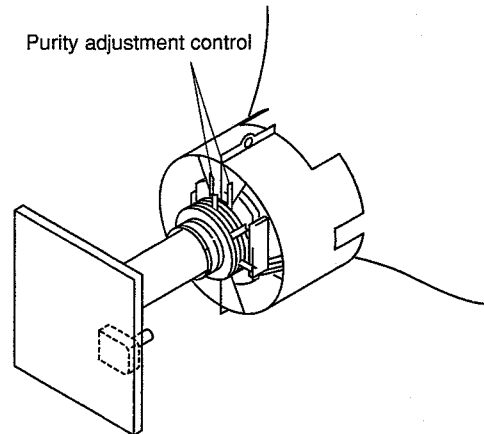

Fig. 2-11

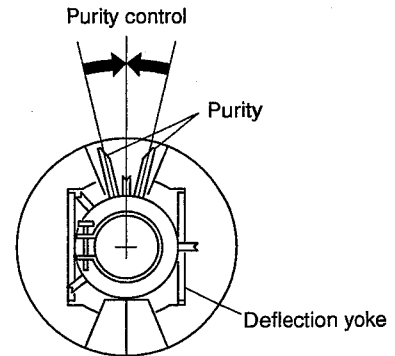

Fig. 2-12

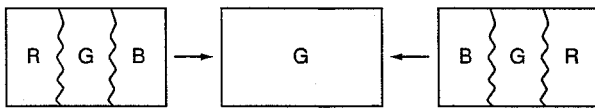
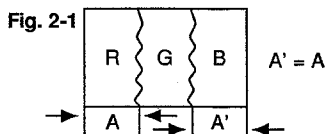

Fig. 2-2

Fig. 2-3

Fig. 2-4

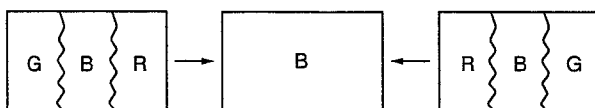

Fig. 2-5

Fig. 2-6

Fig. 2-7

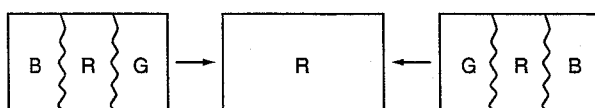

Fig. 2-8

Fig. 2-9

Fig. 2-10

Note

Attach the magnets inside the NTC for the model PVM-9L2 referring to Fig. 2-13.

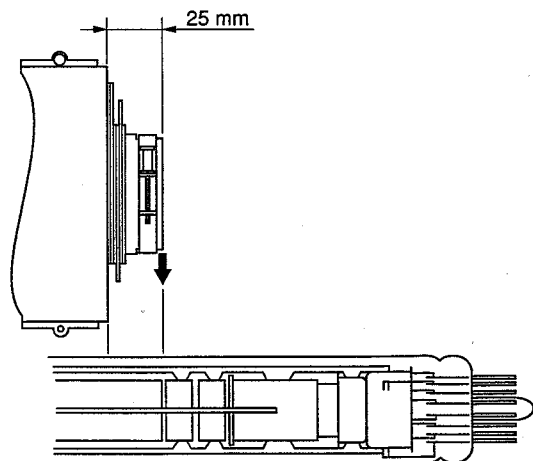

Fig. 2-13

2-9. Deflection Adjustment

Find the following adjustment menu in the layer under the DEFLECTION menu of the service mode.

RASTER H	GEOMETRY
H SIZE	V S LIN
H BLK LEFT	V C LIN
H POSITION	TRAPEZOID
	SIDE PIN
RASTER V	SIDE PIN W
V SIZE	SIDE PIN BAL
V CENTER	PARA CONTROL
V BLK TOP	SIDE PIN S

1. Connect the 480/60I cross hatch signal to the LINE A connector.
2. Enter the service mode.
3. Select the 4:3 normal scan mode and check the followings. (The 16:9 button and UNDER SCAN button turn off.)
DY Inclination Distortion check
Top and bottom V PIN Distortion Check
If the specifications cannot be met, perform the DY Neck Rotation Adjustment.
4. Perform the horizontal trapezoid distortion adjustment using the TLY volume control of DY. If the horizontal trapezoid distortion is difficult to see, select Green Only mode. If the horizontal trapezoid distortion is adjusted significantly, the top and bottom vertical convergence will become out of adjustments.
5. Connect the 480/60I monoscope signal to the LINE A connector.
6. Adjust **V CENTER** of the menu until picture comes to the center of the screen in the vertical direction.
7. Connect the 480/60I cross hatch signal to the LINE A connector.
8. Adjust **V C LIN** and **V S LIN** so that the ratio between the upper and lower halves of the screen becomes normal. Then adjust **V SIZE** to make the screen sizes as specified in 4 : 3 underscanned 4 : 3, 16 : 9 underscanned 16 : 9.
9. Adjust trapezoid distortion and PIN distortion at the corners of screen with **PARA CONTROL**, **TRAPEZOID**, **SIDE PIN BAL**, **SIDE PIN**, **SIDE PIN S**, **SIDE PIN W**. Then adjust the screen size with **H SIZE** to the specified sizes of 4 : 3 and 16 : 9
10. Repeat adjustments from step 7 to step 9 until all specifications are satisfied at the same time. (Tracking)
11. Repeat adjustments from step 7 to step 9 starting from the 4 : 3 UNDER SCAN mode, then 16 : 9 NORMAL SCAN mode and finally 16:9 UNDER SCAN mode. (J/UC)
12. Perform the same adjustment for the 575/50I video signal.

Horizontal frequency	Signal specification	ASPECT ratio
15.625 kHz	575/50I	16 : 9/4 : 3
15.734 kHz	480/60I	16 : 9/4 : 3

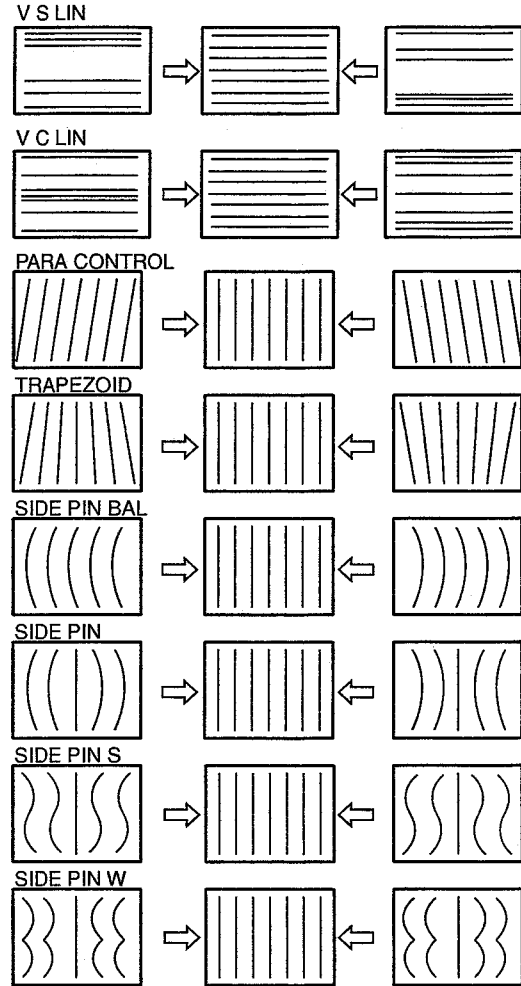

Screen Size Specification

(When inputting a crosshatch signal of H : 16 hatches and V : 10 hatches from VG-854)

480/60I	575/50I
4 : 3 normal scan	4 : 3 normal scan
H : 15.0 ± 0.2 hatches	H : 15.2 ± 0.2 hatches
V : 9.3 ± 0.2 hatches	V : 9.35 ± 0.2 hatches
4 : 3 underscan	4 : 3 underscan
H : 147 ± 2 mm	H : 147 ± 2 mm
V : 110 ± 2 mm	V : 110 ± 2 mm
16 : 9 normal scan	16 : 9 normal scan
H : 15.0 ± 0.2 hatches	H : 15.2 ± 0.2 hatches
V : 95.5 ± 2 mm	V : 94.5 ± 2 mm
16 : 9 underscan	16 : 9 underscan
H : 147 ± 2 mm	H : 147 ± 2 mm
V : 83 ± 2 mm	V : 83 ± 2 mm

2-11. Deflection Yoke Neck Rotation Adjustment

1. If there is mis-convergence on both sides of the X or Y axis of the screen, turn the neck of the deflection yoke in the direction of the arrow to hold the mis-convergence for the entire CRT screen within the tolerance.

- (1) Reverse cross mis-convergence pattern

Move the deflection yoke downward.

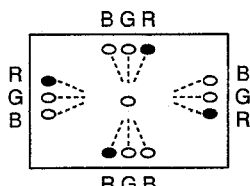

Fig. 2-18

- (2) Cross mis-convergence pattern

Move the deflection yoke upward.

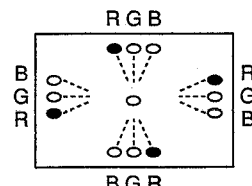

Fig. 2-19

- (3) Pattern of left-sided deflection yoke

Move the deflection yoke to the right when viewed from the CRT screen.

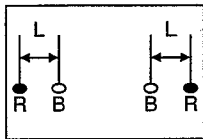

Fig. 2-20

- (4) Pattern of right-sided deflection yoke

Move the deflection yoke to the left when viewed from the CRT screen.

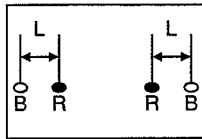

Fig. 2-21

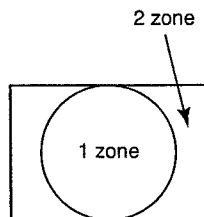

Fig. 2-23

2. Turn the neck of the deflection yoke to align the V pin vertically.
3. Insert the wedge between the deflection yoke and CRT funnel to lock the deflection yoke. (Fig.2-24)

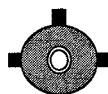
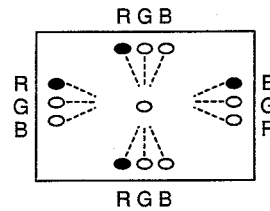

Fig. 2-24

4. The following patterns cannot be corrected by turning the neck. (Figs.2-25, 2-26, and 2-27)



* Gun rotation

The X-axis and Y-axis beams are distorted on both sides.

Fig. 2-25

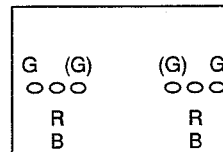

* HCR Large (small)

The horizontal portion of the G raster is wider (narrower) than that of the RB raster on both sides of the screen.

Fig. 2-26

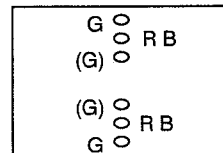

* VCR Large (small)

The vertical portion of the G raster is wider (narrower) than that of the RB raster on both sides of the screen.

Fig. 2-27

2-14. White Balance Adjustment (15k)

1. Connect the 15k windows signal to the LINE A connector.
2. Enter the service mode.
3. Select LINE A.
4. From the operation panel, set as follows :
CONTRAST : 80 (Center clicking)
BRIGHT : 0 (mechanical center)
5. Set the CHROMA knob on the front panel to MIN.
6. Select the following sub menus from the Service Menu in the order of : [SIGNAL] → [WHITE BALANCE] and set [COLOR TEMP] to D65.
7. Select [ADJUST GAIN].
8. While fixing G GAIN/BIAS to 700, adjust B and R for optimum white balance.
Standard value : D65 (X = 313, Y = 329 ± 1 JND)
9. Upon completion of adjustment, press the [MENU] key to return to the previous menu.
10. Change the signal level to 3 cd/m².
11. Select [ADJUST BIAS] of the menu.
12. While fixing G to 700 in the same way as in step 10, adjust B and R for the unity cut-off level.
13. Upon completion of adjustment, press the [MENU] key to return to the previous menu.
14. Repeat adjustments from step 9 to step 14 until all specifications are satisfied all at the same time.
(Tracking)
15. Set [COLOR TEMP] to D93.
16. Repeat adjustments from step 7 to step 14 in the same way.
However, fix the following controls to the fixed values as shown below and make the adjustment.
G GAIN: 700
G BIAS: 400
Standard value : D93 (X = 284, Y = 298 ± 1 JND)

2-15. SUB BRIGHT, SUB CONTRAST Adjustment

1. Connect the monoscope signal to the LINE A connector.
2. Enter the service mode.
3. Select WHITE BALANCE.
4. Select SUB BRIGHT.
5. Set as follows from the front panel:
CONTRAST : 0 (MIN)
BRIGHT : 0 (mechanical center)
6. In the service mode, adjust **SUB-BRIGHT** so that the following setup is obtained at the 20-step gray scale with setup 0:
0 and 5 IRE ⇒ CUT OFF
10 IRE ⇒ Slightly illuminates
7. Select the USER MENU and select USER.CONFIG → NTSC SETUP from the USER MENU. Set the NTSC SETUP to 7.5.
8. In the service mode, adjust **SUB-BRIGHT** so that the following setup is obtained at the 20-step gray scale with setup 7.5:
0 and 5 IRE ⇒ CUT OFF
10 IRE ⇒ Slightly illuminates
9. Set CONTRAST on the operation panel to the mechanical center click position.
10. Turn off the CONTRAST display.
11. Select SUB CONTRAST.
12. Input the window signal whose size is less than what is shown below.

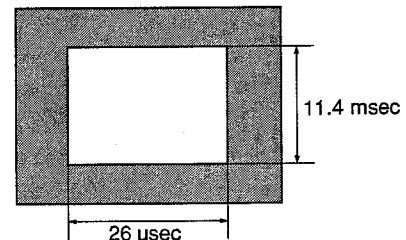

Fig. 2-30

13. Adjust luminance to the under standard value with SUB-CONTRAST.

Standard value :

9 inch MODEL	
SUB CONT	170 cd/m ²

14. Select UNDER SCAN. (4 : 3 UNDER SCAN)
15. Select SUB CONTRAST and adjust luminance to the standard value that is specified in step 13, with SUB-CONTRAST.
16. Select 16 : 9. (16 : 9 UNDER SCAN)
17. Select SUB CONTRAST and adjust luminance to the standard value that is specified in step 13, with SUB-CONTRAST.
18. Select UNDER SCAN. (16 : 9 NORMAL)
19. Select SUB CONTRAST and adjust luminance to the standard value that is specified in step 13, with SUB-CONTRAST.
20. Return to the 4 : 3 NORMAL screen.
21. Turn the POWER OFF.

2-17. Focus Adjustment

Find the following adjustment menu in the layer under the DEFLECTION menu of the service mode.

FOCUS

H DF PARA
H DF PHASE

1. Connect the 480/60I crosshatch signal to the LINE A connector.
2. Perform the coarse focus adjustment until focus is optimized at the center of screen using the following adjustments.
RV707 on C board

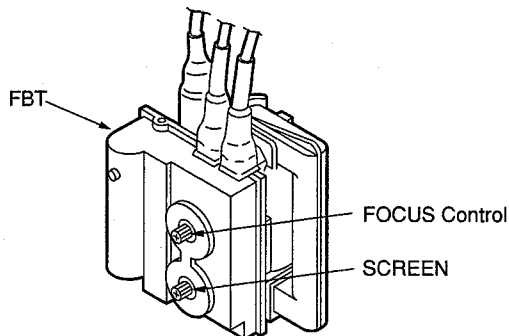

2-18. V BLK Adjustment

The following adjustment sub menus are located in the layer under the DEFLECTION menu of the Service Mode.

RASTER V

V SIZE
V CENTER
V BLK TOP

1. Connect the 480/60I crosshatch signal to the LINE A connector.
2. Adjust the BRIGHT control on the operation panel so that raster becomes visible on screen.
3. Press the UNDER SCAN button to enter the under-scan mode.
4. Press the 16:9 button on the operation panel to enter the 4:3 mode. (LED turns off.)
5. Adjust **V BLK TOP** so that the upper blanking is aligned with the video signal scarcely.
6. Switch the video input to the 575/50I signal and perform the same adjustment.
7. Adjust **V BLK TOP** of the menu so that the upper blanking of screen is immediately before the upper end of video signal.

Section 3

Safety Related Adjustment

This section explains the adjustment procedure when safety related component(s) is replaced. Perform the following adjustment when the safety related component(s) is replaced.

[Preparation]

Equipment Required

- Oscilloscope
Tektronix 2465 or equivalent (with bandwidth of 350 MHz)
- NTSC/PAL component signal generator
Tektronix TG2000 +AVG1 (option module) +AWVG1 (option module) or equivalent
- Monoscope signal generator
ShibaSoku TP22AX or equivalent
- VG (programmable video signal generator)
VG854 or equivalent
- DC power supply
- Digital VOM
Advantest TR6845 or equivalent
- Slide induction transformer
- Electrostatic Voltmeter
- High tension voltmeter
- Ammeter
- Luminance meter
Minolta CA-100 or equivalent.
If the Minolta CA-100 is not available, perform the measurement by visual inspection by comparing the monitor that has already been adjusted earlier with the monitor that you want to adjust.

Note

Start the following adjustments after 5 minutes have passed after the main power is turned on.

When the parts (with a \blacksquare mark on the circuit diagram) shown below are replaced, confirm the matters described in items 3-1 and 3-2 shown below.

D board (HV protector circuit)

- D504, D516, D1518, D1520, IC1508, IC1509, Q503, Q504, Q505, Q506, Q1523, Q1524, Q1525, R522, R523, R524, R526, R1573, R1575, R1577, R1580, R1581, R1582, R1583, R1584, R1593, R1594, R1598, R1599, R1620

D board (IK protector circuit)

- D504, D516, D1519, IC1509, Q503, Q504, Q505, Q506, Q1522, R522, R523, R524, R526, R1574, R1576, R1578, R1585, R1586, R1587, R1588, R1589, R1590, R1591, R1592, R1620

3-1. +B Voltage Check

1. Supply the power source voltage of 130 V_{AC} to the set and turn ON the power.
2. Connect the 480/60I all black signal to the input and adjust the BRIGHT and CONTRAST of the User Control of the main menu to MIN.
3. Check that the +B voltage is 38.5 to 41.5 V.
+B voltage measurement point
Between C549 positive terminal on D board and GND

3-2. Hold-down Circuit Connection Check

1. Supply the power source voltage of 120 V_{AC} to the set and turn ON the power.
2. Connect the 480/60I all black signal to the input and adjust the BRIGHT and CONTRAST of the User Control of the main menu to MIN.
3. Check that the voltage between C1573 positive terminal on D board and GND is 3.80 V or more.

3-3. Protection Circuit Confirmation

3-3-1. HV Protector Circuit Confirmation

1. Supply AC power voltage of 130 ± 3 V_{AC} to the unit and turn the POWER ON.
2. Input a 480/60I all-black signal and set the BRIGHT and CONTRAST VRs on the User Control screen of the menu, to MIN.
3. Check that the voltage between C1573 positive terminal on D board and GND is 3.80 V or more.
4. Apply voltage of 4.6 to 4.8 V from an external DC power supply between C1573 positive terminal on the D board and GND. Confirm that the hold-down circuit does not activate.
5. Apply voltage of 4.99 to 5.14 V from an external DC power supply between C1573 positive terminal on the D board and GND. Confirm that the hold-down circuit does not activate and raster disappears.

3-3-2. IK Protector Circuit Check

1. Connect an ammeter and a variable resistor 10 k Ω between CN502 pin-7 (ABL) and CN1501 pin-6 (OP-6 V) on the D board.
2. Adjust the variable resistor so that the value of the variable resistor becomes maximum (10k Ω).
3. Apply the 130 V_{AC} power source voltage, and turn on the power.
4. Connect the 480/60I all black signal to the input and adjust the BRIGHT and CONTRAST of the User Control of the main menu to MIN.
5. Adjust the variable resistor and confirm that the protector circuit is activated and raster disappears at the ammeter value of 1050 μ A or lower.

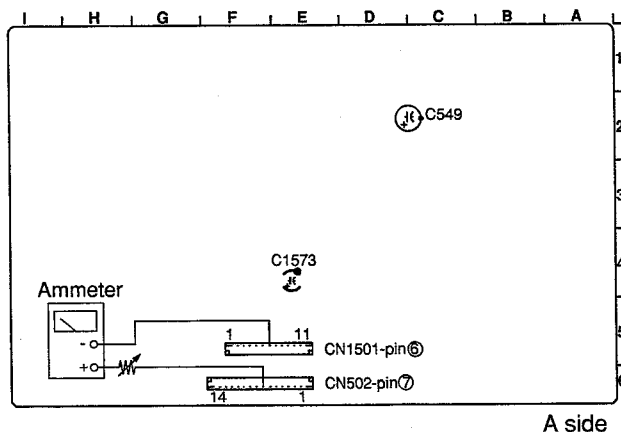

Section 4

Electrical Adjustments

4-1. Equipment Required

- Oscilloscope
Tektronix 2465 or equivalent (with bandwidth of 350 MHz)
- NTSC/PAL component signal generator
Tektronix TG2000 +AVG1 (option module) +AWVG1 (option module) or equivalent
- Monoscope signal generator
ShibaSoku TP22AX or equivalent
- VG (programmable video signal generator)
VG854 or equivalent
- Frequency counter
Advantest TR5821AK or equivalent
- Digital VOM
Advantest TR6845 or equivalent
- Slide induction transformer
- High tension voltmeter
- DC power supply
- Ammeter
- Luminance meter
Minolta CA-100 or equivalent.
If the Minolta CA-100 is not available, perform the measurement by visual inspection by comparing the monitor that has already been adjusted earlier with the monitor that you want to adjust.

Note

Start the following adjustments 5 minutes after the main power is turned on.

4-2. B Board Adjustments

4-2-1. Preparations

1. Test point

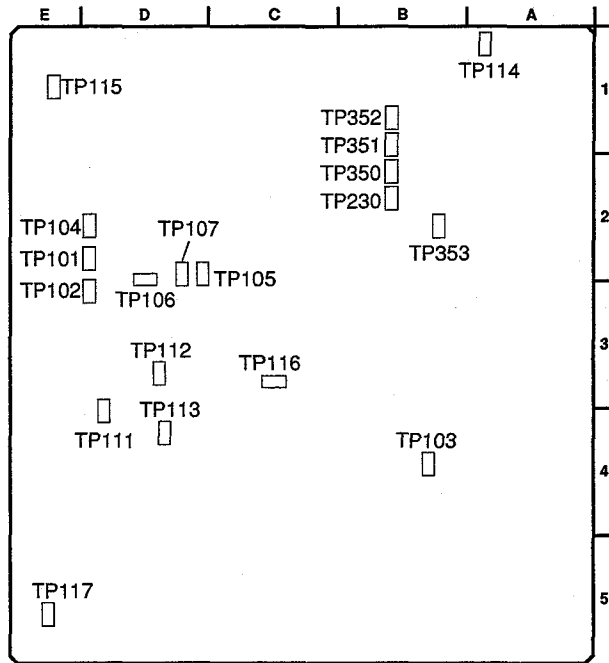

2. Preparation of signals

The B board can process various formats of video signal. The B board must be adjusted for each type of video signal format respectively. Input the signals that meet the following specifications to the connectors on the rear panel of the unit. The component signal should be the Sync-on-Green signal.

Signal			Signal level (mV)
Component	SMPTE	100 % Y	700
		Color bar B-Y	700
		R-Y	700
	75 % Y	Color bar B-Y	700
		R-Y	525
	Color bar B-Y	R-Y	525
BETACAM SETUP 0		100 % Y	714
	Color bar B-Y	1009	
	R-Y	1009	
75 % Y	Color bar B-Y	714	
	R-Y	756	
Color bar B-Y	R-Y	756	
	BETACAM SETUP 7.5	100 % Y	714
Color bar B-Y		933	
	R-Y	933	
75 % Y	Color bar B-Y	714	
	R-Y	700	
Color bar B-Y	R-Y	700	
	Composite	358NTSC	100 % White
Burst			286
PAL	100 % White		700
		Burst	300

3. Connection diagram

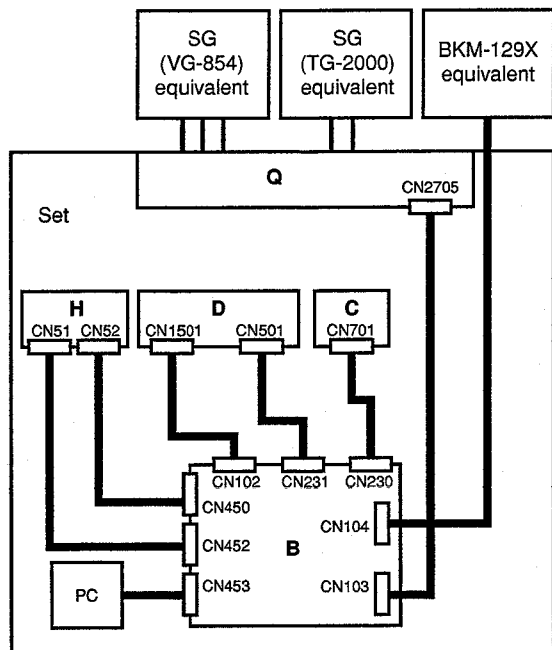

4-2-2. NTSC SETUP 0 Mode Adjustment

4-2-2-1. Y/C Input

1. Input the NTSC SETUP 0 100 % color bar signal to the Y/C IN connector of INPUT A.
2. Adjust Y LEVEL (A2-27) of the menu until the waveform at TP106 meets the standard value.

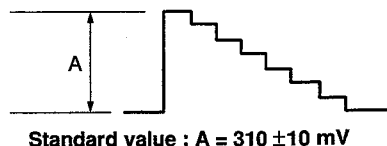

3. Adjust C LEVEL (A2-31) of the menu until the waveform at TP107 meets the standard value.

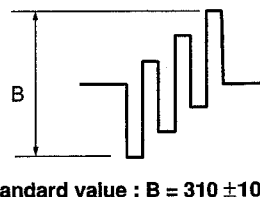

4. Adjust SUB CHROMA (A0-75) of the menu until the portions A and D of the waveform at TP350 (B board) become flat.

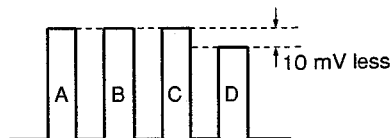

5. Adjust SUB PHASE (A0-8B) of the menu until the portions B and C of the waveform at TP350 become flat.

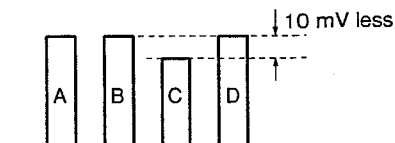

4-2-2-2. Composite Input

1. Input the NTSC SETUP 0 100 % color bar signal to the VIDEO IN connector of INPUT A.
2. Adjust Y LEVEL (A2-23) of the menu until the waveform at TP106 meets the standard value.

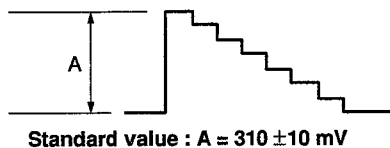

3. Adjust C LEVEL (A2-2E) of the menu until the waveform at TP107 meets the standard value.

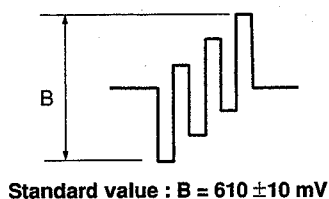

4. Adjust SUB CHROMA (A0-74) of the menu until the portions A and D of the waveform at TP350 (B board) become flat.

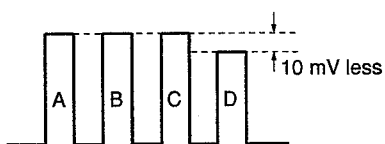

5. Adjust SUB PHASE (A0-8A) of the menu until the portions B and C of the waveform at TP350 become flat.

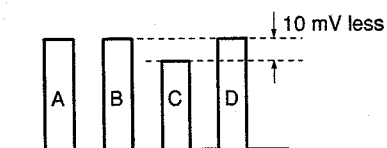

4-2-3. NTSC SETUP 7.5 Mode Adjustment

4-2-3-1. Y/C Input

1. Input the NTSC SETUP 7.5 100 % color bar signal to the Y/C IN connector of INPUT A.
2. Adjust Y LEVEL (A2-28) of the menu until the waveform at TP106 meets the standard value.

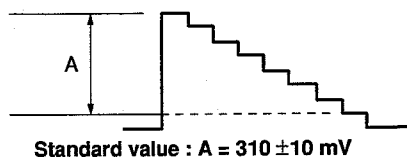

4-2-3-2. Composite Input

1. Input the NTSC SETUP 7.5 100 % color bar signal to the VIDEO IN connector of INPUT A.
2. Adjust Y LEVEL (A2-24) of the menu until the waveform at TP106 meets the standard value.

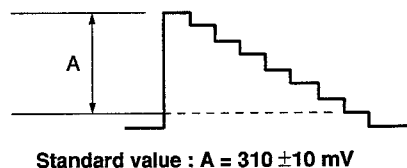

4-2-4. PAL Mode Adjustment

4-2-4-1. Y/C Input

1. Input the PAL 100 % color bar signal to the Y/C IN connector of INPUT A.
2. Adjust Y LEVEL (A2-2A) of the menu until the waveform at TP106 meets the standard value.

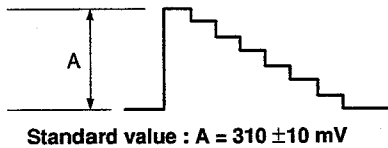

3. Adjust C LEVEL (A2-33) of the menu until the waveform at TP107 meets the standard value.

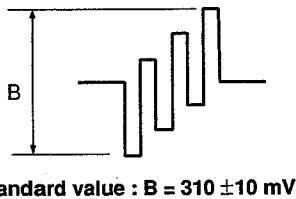

4. Adjust SUB CHROMA (A0-79) of the menu until the portions A and D of the waveform at TP350 (B board) become flat.

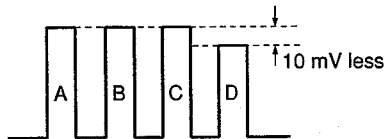

5. Adjust SUB PHASE (A0-8F) of the menu until the portions B and C of the waveform at TP350 become flat.

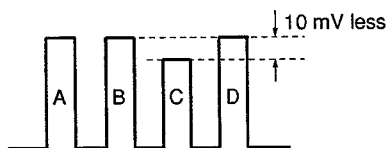

4-2-4-2. Composite Input

1. Input the PAL 100 % color bar signal to the VIDEO IN connector of INPUT A.
2. Adjust Y LEVEL (A2-26) of the menu until the waveform at TP106 meets the standard value.

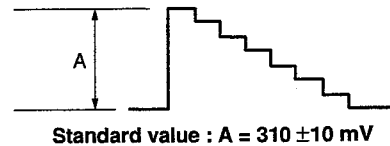

3. Adjust C LEVEL (A2-30) of the menu until the waveform at TP107 meets the standard value.

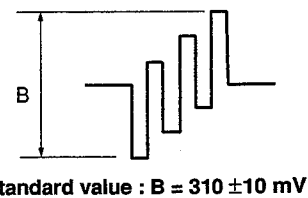

4. Adjust SUB CHROMA (A0-78) of the menu until the portions A and D of the waveform at TP350 (B board) become flat.

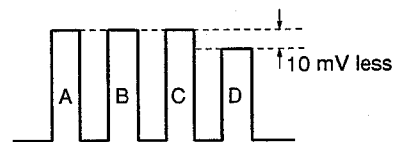

5. Adjust SUB PHASE (A0-8E) of the menu until the portions B and C of the waveform at TP350 become flat.

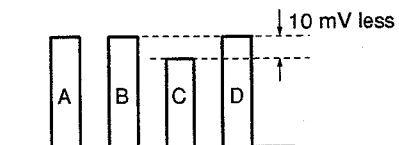

4-2-5. Y PBPR SMPTE (601) Signal Adjustment

1. Input the 15 kHz/60 Hz Y PBPR SMPTE (601) 100% color bar signal to the Y/PB/PR connector of BKM-129X.
2. Press the OPTION switch on the control panel to switch to Y PBPR SMPTE.
3. Adjust Y LEVEL (A2-2B) of the menu until the waveform at TP106 meets the standard value.

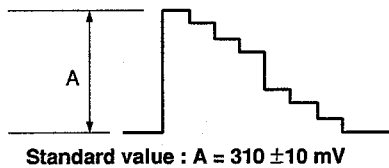

4. Adjust C LEVEL (A2-34) of the menu until the waveform at TP107 meets the standard value.

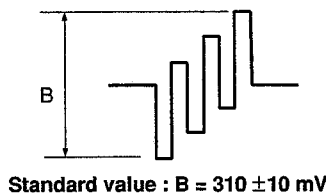

5. Adjust SUB CHROMA (A0-7A) of the menu until the portions A and D of the waveform at TP350 (B board) become flat.

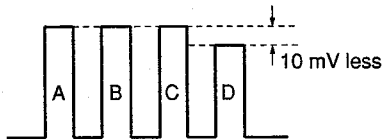

6. Adjust SUB PHASE (A0-90) of the menu until the portions B and C of the waveform at TP350 become flat.

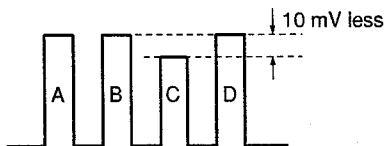

4-2-6. Y PBPR BETACAM SETUP 0 Signal Adjustment

1. Input the 15 kHz/60 Hz Y PBPR BETACAM SETUP 0 100 % color bar signal to the Y/PB/PR connector of BKM-129X.
2. Press the OPTION switch on the control panel to switch to Y PBPR BETACAM SETUP 0.
3. Adjust Y LEVEL (A2-2C) of the menu until the waveform at TP106 meets the standard value.

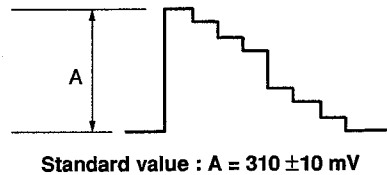

4. Adjust C LEVEL (A2-35) of the menu until the waveform at TP107 meets the standard value.

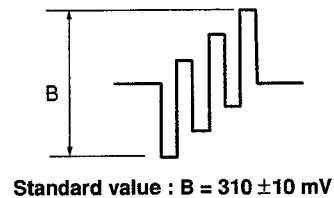

4-2-7. Y PBPR BETACAM SETUP 7.5 Signal Adjustment

1. Input the 15 kHz/60 Hz Y PBPR BETACAM SETUP 7.5 100 % color bar signal to the Y/PB/PR connector of BKM-129X.
2. Press the OPTION switch on the control panel to switch to Y PBPR BETACAM SETUP 7.5.
3. Adjust Y LEVEL (A2-2D) of the menu until the waveform at TP106 meets the standard value.



Standard value : $A = 310 \pm 10 \text{ mV}$

4. Adjust C LEVEL (A2-36) of the menu until the waveform at TP107 meets the standard value.

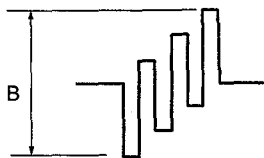

Standard value : $B = 310 \pm 10 \text{ mV}$

5. Adjust SUB CHROMA (A0-7B) of the menu until the portions A and D of the waveform at TP350 (B board) become flat.

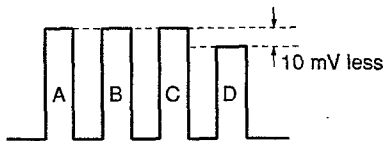

6. Adjust SUB PHASE (A0-91) of the menu until the portions B and C of the waveform at TP350 become flat.

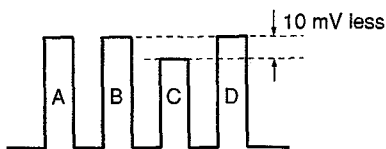

Section 5

Theory of Operation

5-1. D Board and P Board

Power Supply Block

When 13 V is supplied to the D board CN1505 from the G board, 13 V is supplied to the DC-DC converters for 40 V, 12 V, 6 V and -6 V respectively through the relay (RY1501).

The DC-DC converter generating 40 V consists of IC505, Q508, Q509, Q510 and D505. The generated 40 V is supplied to FBT as the power supply for deflection system.

The DC-DC converter generating 12 V consists of IC505, Q1501, Q1502, Q1503, Q1504, Q1505, D1502 and D1503. The generated 12 V is supplied to the B board as its power.

The DC-DC converter generating 6 V consists of IC1501, Q1506, Q1508, Q1509, Q1512, and D1506.

The DC-DC converter generating -6 V consists of IC1501, Q1507, Q1510, Q1511, Q1513, and D1507.

The generated 6 V and -6 V are supplied to the option boards as its power.

The power regulator for 5 V is the 3-terminal power regulator consisting of IC1503 and IC1504. The 5 V power is generated from the above regulated 6 V and supplied to the B board as its power.

When the unit is operated on DC power, the DC power is supplied from lithium battery via CN1502 or external DC power through CN1503. When the power switch is turned on, the relay is switched to the DC position so that the power is supplied to the respective DC-DC converters.

If the 13 V power is supplied from the G board at the same time, it activates the AC prioritize circuit Q1514 so that the DC power supply is stopped and the DC power supply is also stopped. Therefore, be sure to disconnect the AC power cord from AC power source.

When the battery voltage decreases lower than DC 9.5 V, the unit is shut down by IC1506 in order to protect battery. When the battery voltage increases higher than DC 21 V, the OVP is activated by IC1506.

Deflection Block

Deflection drive pulse is generated by IC502 as it is synchronized with the H. SYNC at CN501 pin-4 and V. SYNC at pin-12. The horizontal deflection drive pulse is supplied to Q802 and Q803 on the P board via CN502 pin-4 to drive the horizontal deflection system.

At the same time, the distortion correction waveforms including DC component are supplied to Q513 via IC501 from IC502 pin-9 in order to correct the H. SIZE PIN distortion via bus control.

The vertical deflection is performed by the sawtooth wave that is output from IC502 pin-8 and is supplied via IC504 to IC506. V SIZE and V.LIN are adjusted by the IC 502 bus control.

High Tension Block

The H. OUT pulse that is generated by Q803 on the P board, is boosted by FBT to about 16 kV and supplied to CRT.

Audio Block

The audio signal is input from CN1507 pin-2 of the D board. It is amplified by IC1507 and supplied to speaker via AUDIO OUT.

Degauss Block

Because this unit can be operated on battery, the DC degauss circuit is incorporated.

When the power switch is turned on, and also when the DEGAUSS switch on the front panel is pressed, the degauss drive signal is supplied to CN1507 pin-5 from microprocessor. IC1510 and IC1511 are oscillated as triggered by the degauss drive signal. The voltage that is charged by the time constant of R1818 and C1589 generates the damped vibration signal and the degaussing is performed.

5-2. G Board

The power supply block of this board consists of the following two switching regulators.

1. The power regulator for improving power factor to conform to the power supply harmonics regulation.
2. The power regulator for the main power supply that supplies the necessary voltages to the signal system circuit and to the deflection and high voltage circuits.

Power factor improvement block

The power factor improvement block uses the active filter IC module (IC666) of the current-critical type boost-chopper system to conform to the power supply harmonics regulation.

The power factor improvement block consists of IC666, T602, C630, C615 and the related parts.

IC666 is the module IC containing control IC, switching FET, boost diode and input/output voltage detector inside the module.

The basic operation of the power factor improvement block is described below. When the VCC power is supplied, it turns on FET so that a current starts flowing in the primary winding of T602 and FET. This current increases with the slope of $V_{in}(\text{RMS})/L$. Here, L is the inductance value of the primary winding of T602. The FET current is monitored by the source current detecting resistor connected between pin-4 and pin-7 of IC666. When the detected voltage increases and reaches the set value determined by the multiplier located inside the control IC, the FET is turned off. Then a current that decreases with the slope of $(V_d - V_{in}(\text{RMS}))/L$ flows in the boost diode. When this current becomes zero, the FET is turned on. By the circuit operation as described above, the current-critical operation is realized. (Vd: Voltage across C615, Vin: Input power voltage)

The above-described single cycle of the circuit operation is repeated all the time. When this circuit operation is observed during a half-cycle period of a commercial power frequency, the control IC controls the ON/OFF timing of the FET so that the peak value of the choke current resembles to the sine waveform of the input power voltage.

As the result of this control by the control IC, the input voltage waveform resembles to the input current waveform so that the power factor is improved. As the result of this control, the voltage Vd across C615 becomes higher than the peak value of the input power voltage, and is set to about 380 V regardless of the input power voltage.

Power regulator for the main power supply

The circuit system of this power regulator is the separate-excitation type current composite resonant system that realizes high efficiency and low noise. The main power supply block consists of: IC603, IC690, T604, C644, C623 and the secondary rectifier circuit of T604.

IC603 is the multi-chip module in which the four chip parts of control block, FET drive block, switching FET block (high side) and switching FET block (low side) are connected together inside the IC by the bonding wires.

Circuit operation of this regulator is as follows. The two FET switches, the two capacitors C644 and C623, and the transformer T604 form a half bridge rectifier circuit for the input voltage Vd where the secondary circuit of the transformer T604 has the full wave rectifier circuit with center tap.

IC603 receives the control signal from IC609 that performs the constant voltage control of the +13 V line via the isolator PH601. This control signal changes the oscillating frequency and realizes the constant voltage power regulation.

Section 6 Semiconductors

AN5265

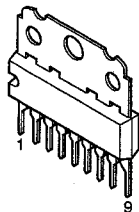

BA05T



BA10393F-E2
BA7046F
BA7046F-E2
CXA1211M
CXA1211M-T4
LM358M
LM393PS
LM393PS-E20
M24C08-WMN6T
M24C08-WMN6T(A)
MM1113XFBE
NJM2233BM
NJM2233BM(Te2)
TC7W32F
TC7W32F(Te12R)
TC7W34FU(Te12R)

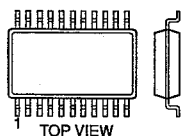

8pin SOP

BU4021BF-E2
MC74HC157AFEL
MC74HC4053AFEL
MC74HC4538AF
MC74HC4538AFEL
TC74HC4538AF
TC74HC4538AF-TP2
TL494CNS
TL494CNS-E20

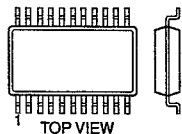

16pin SOP

CXA1739S

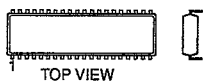

48pin DIP

CXA2163AQ-T6

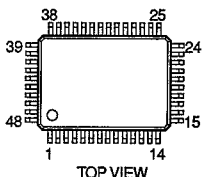

CXA8071CP



30pin DIP

IR2112

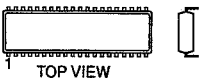

14pin DIP

LM358M-FL63

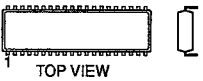

8pin DIP

M62399FP-TE2

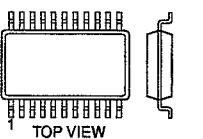

20pin SOP

MB88141APF-ER

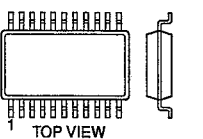

24pin SOP

MB90096PF-G-223-BND-ER

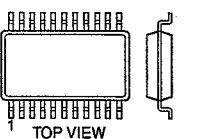

28pin SOP

MC141627FT

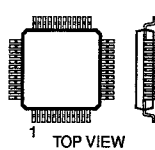

48pin QFP

MCR5102



19pin ZIP

MZ1532

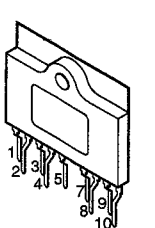

NJM7805FA

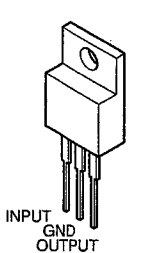

S-80842ANNP-ED6-T2

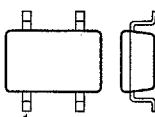

4pin CHIP

SE-012N

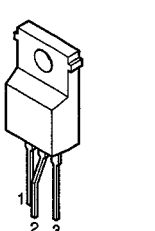

TC4S11F
TC4S11F(Te85R)
TC-4S30F
TC4S30F(Te85R)
TC7S08FU(Te85R)
TC7S32FU(Te85R)

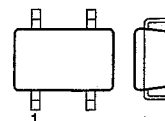

5pin CHIP

TDA8177

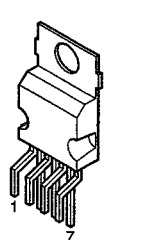

TL1451ACNS
TL1451ACNSR

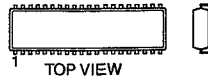

16pin DIP

UPC1093J
UPC1093J-T

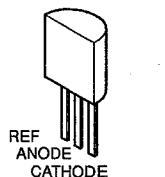

UPD70F3033AYGC-8EU

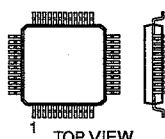

100pin QFP

Transistor, Diode

2SA1037AK-T146-QR
 2SA1037AK-T146-R
 2SA1338-5-TB
 2SB709A-QRS-TX
 2SC1623-L5L6
 2SC2412K-T-146-QR
 2SC3392-5-TB
 2SD601A-Q
 2SD601A-QRS-TX
 DTA144EKA-T146
 DTC114EK
 DTC114EKA-T146
 DTC114GKA
 DTC114GKAT146
 DTC144EKA
 DTC144EKA-T146

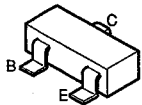

2SA1091-O
 2SA1091O-TPE2
 2SC2551-O
 2SC2551O-TPE2
 2SC2551R-TPE2

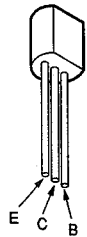

2SC2611

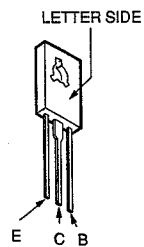

2SC2958-L
 2SC2958-TL
 2SD774-34
 2SD774-T-3

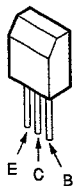

2SD1134-C

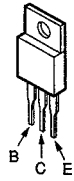

2SD2578-CA

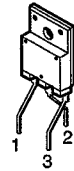

2SJ377(TE16L)

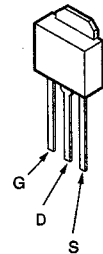

2SK2231

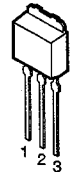

2SK3148-01

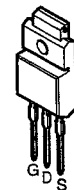

IRF1630G-LF



IRFU110

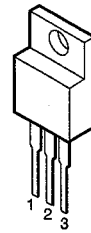

1SS184
 1SS184-TE85L

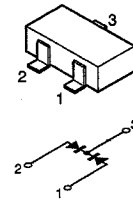

1SS226
 1SS226-TE85L
 HSM83-TL
 MA157-TX

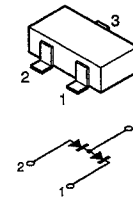

1SS83
 1SS83TD
 D1NL20U-TR
 EGP20G
 EL1Z
 GP08D
 GP08DPKG23
 RGP10GPKG23

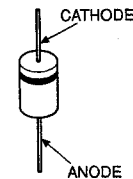

D30SC4M

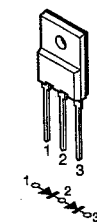

D4SB60L

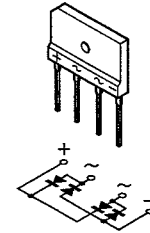

FMN-G12S

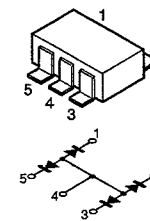

MA111-TX
 RD10SB1-T1
 RD12SB1-T1
 RD13SB2
 RD13SB2-T1
 RD18SB2-T1
 RD22SB2-T1
 RD27SB-T1
 RD4.7SB2
 RD4.7SB2-T1
 RD5.1SB2-T1
 RD5.1SB2-T2
 RD6.2SB2-T1

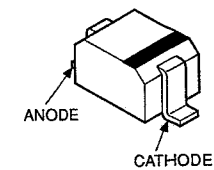

NSQ03A06-TE16L
 SC311-6-TE12RA
 SC802-04
 SC802-04-TE12RA

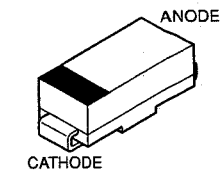

RB441Q-40T-77

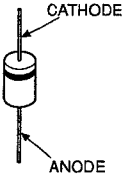

SEL2410E

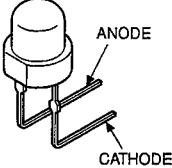

RD10SB1

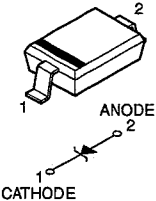

SEL3810DLC05

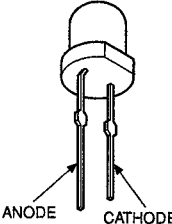

RD18SB1-T1

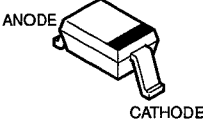

UDZSTE-173.6B

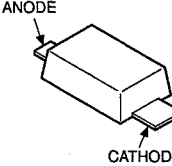

**RD5.1SB1-T1
RD5.1SB3-T1
RD5.1SB3-T2**

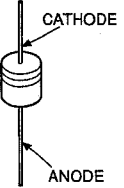

RGP15J-6040G23

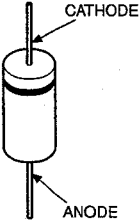

**RM11A
RM11C**

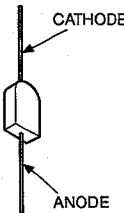

Section 7 Spare Parts

7-1. Notes on Repair Parts

1. Safety Related Components Warning

WARNING

Components marked Δ are critical to safe operation. Therefore, specified parts should be used in the case of replacement.

WARNHINWEIS

Les composants identifiés par la marque Δ sont critiques pour la sécurité. Ne les remplacer que par une pièce portant le numéro spécifié.

2. Standardization of Parts

Some repair parts supplied by Sony differ from those used for the unit. These are because of parts commonality and improvement.

Parts List has the present standardized repair parts.

3. Stock of Parts

Parts marked with "o" at SP (Supply Code) column of the Spare Parts list may not be stocked. Therefore, the delivery date will be delayed.

Items with no part number and no description are not stocked because they are seldom required for routine service.

4. Units for Capacitors, Inductors and Resistors

The following units are assumed in Schematic Diagrams, Electrical Parts List and Exploded Views unless otherwise specified.

Capacitors	: μF
Inductors	: μH
Resistors	: Ω

5. X-ray Radiation Safety Related Parts

The components marked \boxtimes in this Spare Parts List have been carefully factory-selected for each set in order to satisfy regulations regarding X-ray radiation.

Top Cover Section

7-2. Exploded Views

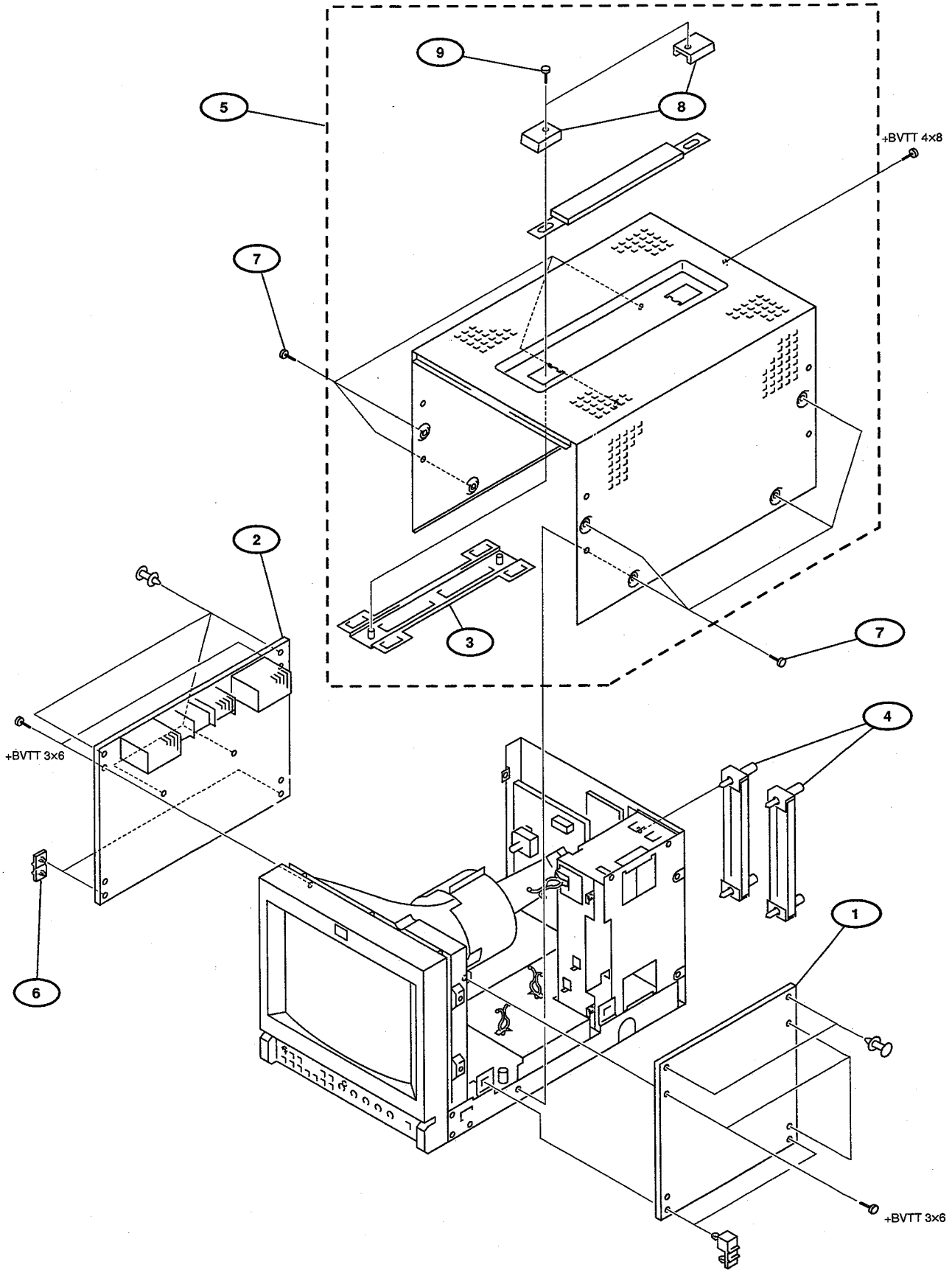

Top Cover Section

No.	Part No.	SP	Description	
1	A-1300-858-A	s	MOUNTED CIRCUIT BOARD B	
2	A-1300-859-A	s	MOUNTED CIRCUIT BOARD D	
3	X-4030-273-1	o	REINFORCEMENT ASSY, HANDLE	
4	X-4037-166-1	o	PANEL ASSY, BLANK	
5	X-4041-236-1	s	CABINET ASSY	
6	3-696-606-02	o	HINGE, V1	(PA)
7	4-034-834-01	s	SCREW (CLAW) (4X6)	(ST)
8	4-034-847-01	s	HANDLE (BASE)	
9	4-035-452-01	s	SCREW (+B M4X12)	

Screws/Washers

7-685-871-01	s	SCREW +BVTT 3X6
7-685-881-09	s	SCREW +BVTT 4X8

Bezel Assy and Picture Tube Section

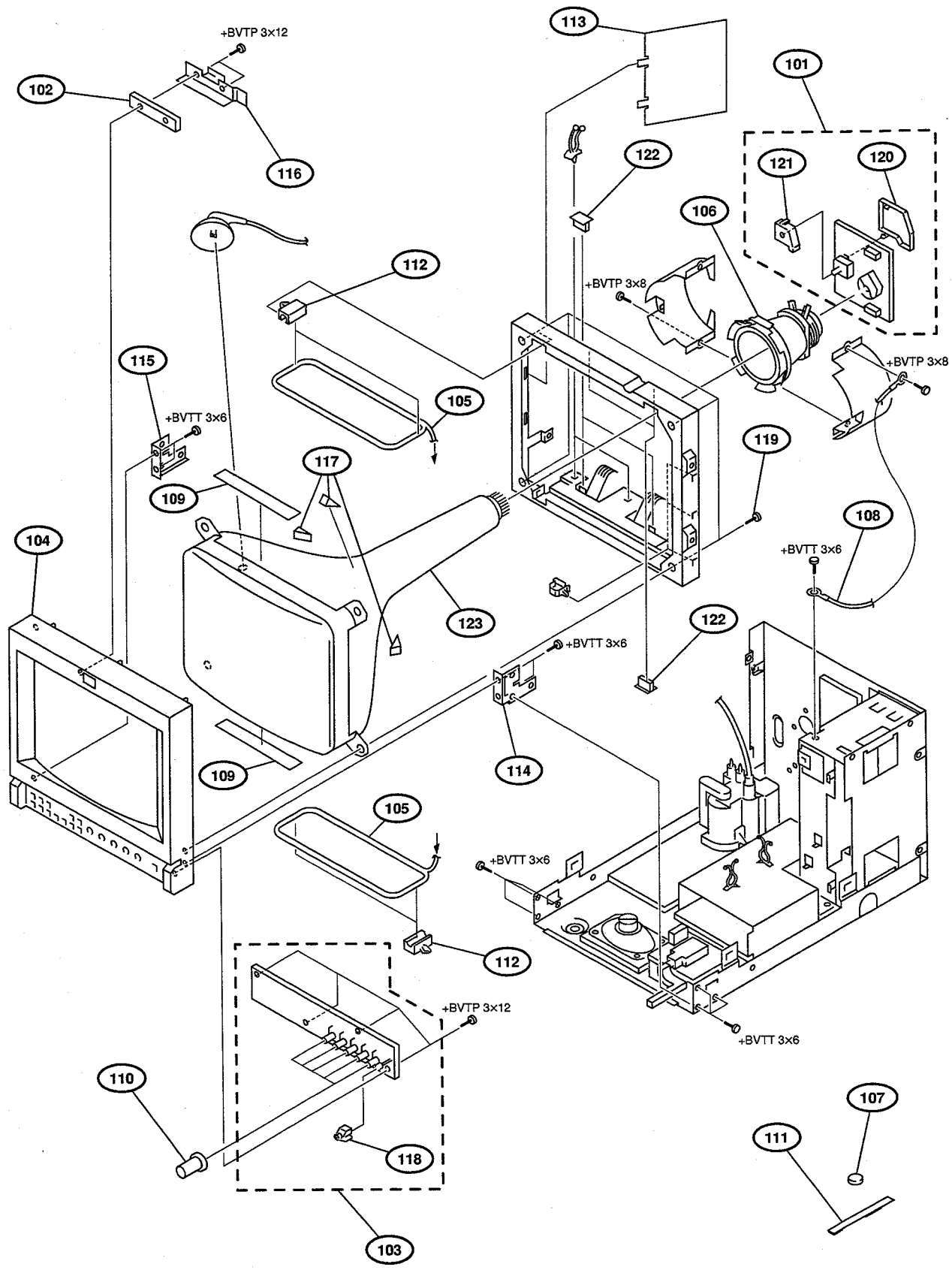

Bezel Assy and Picture Tube Section

No.	Part No.	SP	Description
101	A-1401-775-A	s	MOUNTED CIRCUIT BOARD C
102	A-1401-776-A	s	MOUNTED CIRCUIT BOARD X
103	A-1401-777-A	s	MOUNTED CIRCUIT BOARD H
104	X-4041-235-1	s	BEZEL ASSY
105	△ 1-419-306-11	s	COIL, DEGAUSS
106	△ 1-451-319-22	s	DEFLECTION YOKE (Y9FXC)
107	1-452-884-12	o	MAGNET
108	1-923-511-84	o	WIRE UL1007 AWG18 110MM BLK
109	4-035-332-01	s	CLOTH, PROTECTION
110	4-043-802-02	s	KNOB, CONTROL
111	4-051-735-42	s	PIECE A (75), CONV, CORRECT
112	4-072-725-01	o	HOLDER, DEGAUSS COIL
113	4-093-003-01	o	INSULATED PLATE, ANODE
114	4-093-004-01	o	BRACKET (R), BEZEL
115	4-093-005-01	o	BRACKET (L), BEZEL
116	4-093-007-01	o	PLATE, LIGHT INTERCEPTION
117	4-309-369-00	s	SPACER, DY
118	4-348-208-00	o	HOLDER, LED
119	4-365-808-01	s	SCREW (5), TAPPING
120	4-376-132-11	o	COVER (REAR LID), CV VOL
121	4-376-133-11	o	COVER (MAIN), CV VOL
122	4-380-534-01	s	CAP,DGC
123	△ 8-737-154-00	s	PICTURE TUBE (A20JKU10X)

Screws/Washers

7-685-646-79	s	SCREW +BVTP 3X8
7-685-648-79	s	SCREW +BVTP 3X12
7-685-871-01	s	SCREW +BVTT 3X6

Chassis Section

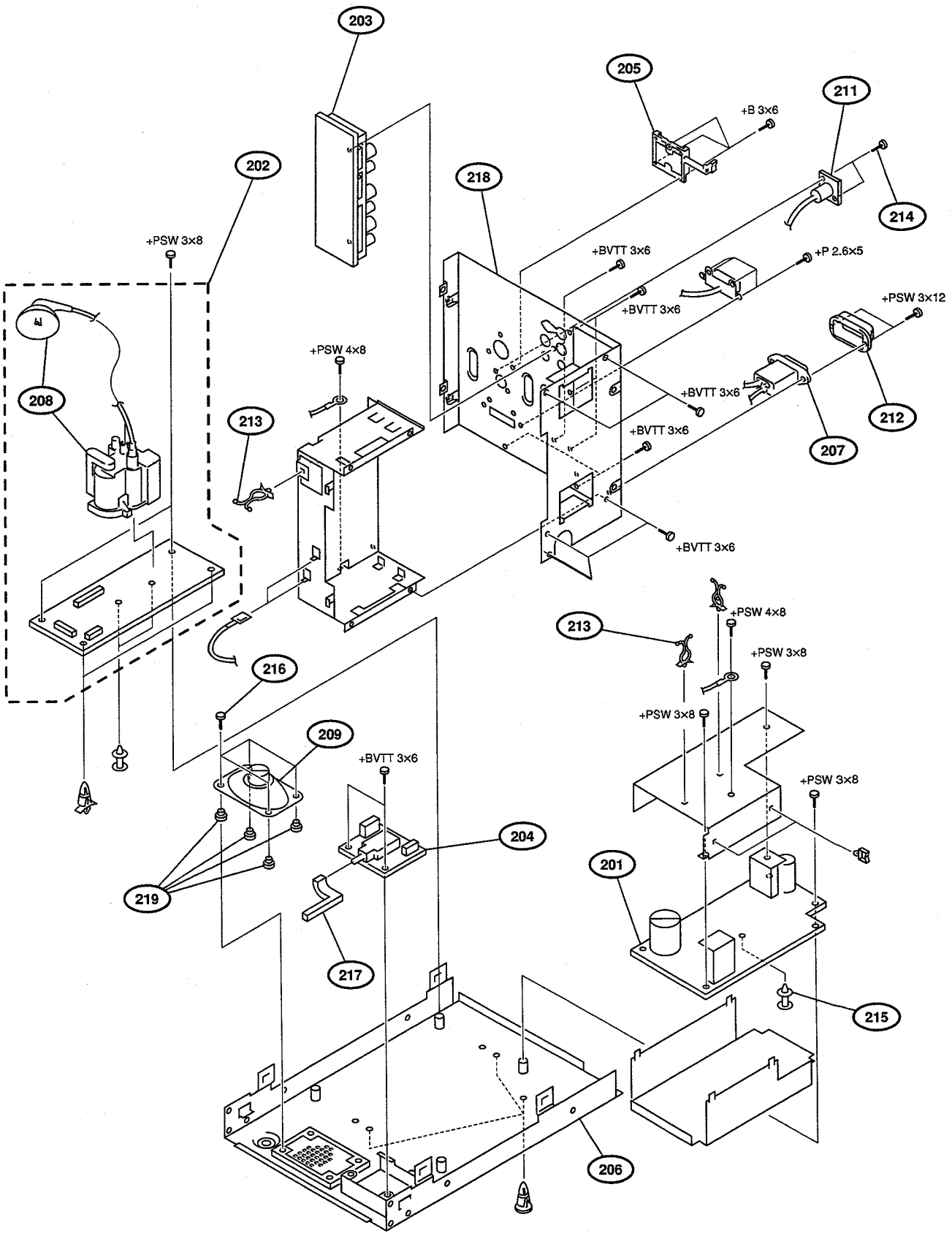

Chassis Section

No.	Part No.	SP	Description
201	A-1300-856-A	s	MOUNTED CIRCUIT BOARD G
202	A-1300-857-A	s	MOUNTED CIRCUIT BOARD P
203	A-1302-028-A	s	MOUNTED CIRCUIT BOARD Q
204	A-1401-778-A	s	MOUNTED CIRCUIT BOARD J
205	A-8278-025-C	s	V MOUNT ASSY (MECHA)
206	X-4041-238-1	o	CHASSIS ASSY, BOTTOM
207	△ 1-251-382-11	s	INLET, AC 3P (WITH NOISE FILTER)
208	△ 1-439-526-13	s	TRANSFORMER ASSY, FLYBACK
209	1-544-063-12	s	SPEAKER (7X5CM)
211	1-900-269-81	s	XLR CONNECTOR ASSY
212	2-990-241-02	s	HOLDER (A), PLUG
213	4-035-160-01	s	PURSE LOCK (S) (DIA. 12)
214	4-035-802-01	s	SCREW (RK 2.6X6)
215	4-056-942-01	s	SPACER, MINIATURE CARD
216	4-086-472-01	s	SCREW (M3X4), STEP
217	4-093-000-01	s	BUTTON, POWER SWITCH
218	4-093-019-01	s	COVER, REAR
219	4-379-189-01	o	CUSHION, SPEAKER

Screws/Washers

7-627-556-58	s	SCREW PRECISION +P 2.6X5
7-682-547-09	s	SCREW +B 3X6
7-682-948-09	s	SCREW +PSW 3X8
7-682-950-09	s	SCREW +PSW 3X12
7-682-961-01	s	SCREW +PSW 4X8
7-685-871-01	s	SCREW +BVTT 3X6
7-685-871-09	s	SCREW +BVTT 3X6

7-3. Electrical Parts List

B BOARD

Ref. No. or Q'ty	Part No.	SP	Description
1pc	A-1300-858-A	s	MOUNTED CIRCUIT BOARD, B
1pc	7-322-065-48	o	RUBBER, SILICONE RTV (KE-3490)
C101	1-126-935-11	s	CAPACITOR, ELECT 470MF/16V
C102	1-126-947-11	s	CAPACITOR, ELECT 47MF/35V
C103	1-126-947-11	s	CAPACITOR, ELECT 47MF/35V
C104	1-126-947-11	s	CAPACITOR, ELECT 47MF/35V
C105	1-101-884-00	s	CAPACITOR, CERAMIC 56PF/50V (SL)
C109	1-107-826-11	s	CAPACITOR, CHIP CERAMIC 0.1MF
C110	1-107-823-11	s	CAPACITOR, CERAMIC 0.47MF/16V
C112	1-126-933-11	s	CAPACITOR, ELECT 100MF/16V
C113	1-126-933-11	s	CAPACITOR, ELECT 100MF/16V
C114	1-125-889-11	s	CAPACITOR, C.CERAMIC 2.2MF
C117	1-162-970-11	s	CAPACITOR CERAMIC 0.01MF/25V B
C118	1-164-227-11	s	CAPACITOR, CERAMIC 0.022MF/25V
C119	1-162-970-11	s	CAPACITOR CERAMIC 0.01MF/25V B
C120	1-162-970-11	s	CAPACITOR CERAMIC 0.01MF/25V B
C121	1-126-933-11	s	CAPACITOR, ELECT 100MF/16V
C122	1-125-837-11	s	CAPACITOR, CHIP CERAMIC 1MF/6.3V
C123	1-162-915-11	s	CAPACITOR, CERAMIC 10PF/50V CH
C124	1-162-970-11	s	CAPACITOR CERAMIC 0.01MF/25V B
C125	1-126-964-11	s	CAPACITOR, ELECT 10MF/50V
C126	1-107-826-11	s	CAPACITOR, CHIP CERAMIC 0.1MF
C128	1-126-964-11	s	CAPACITOR, ELECT 10MF/50V
C129	1-126-964-11	s	CAPACITOR, ELECT 10MF/50V
C130	1-125-837-11	s	CAPACITOR, CHIP CERAMIC 1MF/6.3V
C131	1-107-826-11	s	CAPACITOR, CHIP CERAMIC 0.1MF
C132	1-107-826-11	s	CAPACITOR, CHIP CERAMIC 0.1MF
C133	1-162-970-11	s	CAPACITOR CERAMIC 0.01MF/25V B
C134	1-162-970-11	s	CAPACITOR CERAMIC 0.01MF/25V B
C135	1-126-947-11	s	CAPACITOR, ELECT 47MF/35V
C136	1-126-947-11	s	CAPACITOR, ELECT 47MF/35V
C137	1-162-970-11	s	CAPACITOR CERAMIC 0.01MF/25V B
C138	1-107-826-11	s	CAPACITOR, CHIP CERAMIC 0.1MF
C139	1-162-970-11	s	CAPACITOR CERAMIC 0.01MF/25V B
C140	1-107-826-11	s	CAPACITOR, CHIP CERAMIC 0.1MF
C141	1-107-826-11	s	CAPACITOR, CHIP CERAMIC 0.1MF
C142	1-107-826-11	s	CAPACITOR, CHIP CERAMIC 0.1MF
C143	1-126-963-11	s	CAPACITOR, ELECT 4.7MF/50V
C144	1-162-970-11	s	CAPACITOR CERAMIC 0.01MF/25V B
C145	1-107-826-11	s	CAPACITOR, CHIP CERAMIC 0.1MF
C146	1-107-826-11	s	CAPACITOR, CHIP CERAMIC 0.1MF
C147	1-107-826-11	s	CAPACITOR, CHIP CERAMIC 0.1MF
C148	1-107-826-11	s	CAPACITOR, CHIP CERAMIC 0.1MF
C149	1-107-826-11	s	CAPACITOR, CHIP CERAMIC 0.1MF
C150	1-162-970-11	s	CAPACITOR CERAMIC 0.01MF/25V B
C151	1-162-970-11	s	CAPACITOR CERAMIC 0.01MF/25V B
C152	1-162-970-11	s	CAPACITOR CERAMIC 0.01MF/25V B
C153	1-126-933-11	s	CAPACITOR, ELECT 100MF/16V
C155	1-107-826-11	s	CAPACITOR, CHIP CERAMIC 0.1MF
C156	1-126-933-11	s	CAPACITOR, ELECT 100MF/16V
C157	1-162-970-11	s	CAPACITOR CERAMIC 0.01MF/25V B
C159	1-107-826-11	s	CAPACITOR, CHIP CERAMIC 0.1MF
C162	1-126-933-11	s	CAPACITOR, ELECT 100MF/16V
C163	1-162-970-11	s	CAPACITOR CERAMIC 0.01MF/25V B
C164	1-107-826-11	s	CAPACITOR, CHIP CERAMIC 0.1MF
C165	1-107-826-11	s	CAPACITOR, CHIP CERAMIC 0.1MF
C166	1-107-826-11	s	CAPACITOR, CHIP CERAMIC 0.1MF
C169	1-162-970-11	s	CAPACITOR CERAMIC 0.01MF/25V B

(B BOARD)

Ref. No. or Q'ty	Part No.	SP	Description
C171	1-125-889-11	s	CAPACITOR, C.CERAMIC 2.2MF
C172	1-162-970-11	s	CAPACITOR CERAMIC 0.01MF/25V B
C173	1-107-826-11	s	CAPACITOR, CHIP CERAMIC 0.1MF
C174	1-162-970-11	s	CAPACITOR CERAMIC 0.01MF/25V B
C175	1-107-826-11	s	CAPACITOR, CHIP CERAMIC 0.1MF
C176	1-126-933-11	s	CAPACITOR, ELECT 100MF/16V
C177	1-126-964-11	s	CAPACITOR, ELECT 10MF/50V
C178	1-162-970-11	s	CAPACITOR CERAMIC 0.01MF/25V B
C179	1-162-970-11	s	CAPACITOR CERAMIC 0.01MF/25V B
C180	1-162-970-11	s	CAPACITOR CERAMIC 0.01MF/25V B
C181	1-162-970-11	s	CAPACITOR CERAMIC 0.01MF/25V B
C182	1-126-964-11	s	CAPACITOR, ELECT 10MF/50V
C183	1-126-964-11	s	CAPACITOR, ELECT 10MF/50V
C184	1-126-964-11	s	CAPACITOR, ELECT 10MF/50V
C185	1-126-964-11	s	CAPACITOR, ELECT 10MF/50V
C186	1-126-964-11	s	CAPACITOR, ELECT 10MF/50V
C187	1-126-964-11	s	CAPACITOR, ELECT 10MF/50V
C188	1-126-964-11	s	CAPACITOR, ELECT 10MF/50V
C189	1-126-964-11	s	CAPACITOR, ELECT 10MF/50V
C190	1-126-964-11	s	CAPACITOR, ELECT 10MF/50V
C191	1-126-964-11	s	CAPACITOR, ELECT 10MF/50V
C193	1-126-935-11	s	CAPACITOR, ELECT 470MF/16V
C194	1-162-970-11	s	CAPACITOR CERAMIC 0.01MF/25V B
C195	1-107-826-11	s	CAPACITOR, CHIP CERAMIC 0.1MF
C196	1-162-970-11	s	CAPACITOR CERAMIC 0.01MF/25V B
C198	1-165-176-11	s	CAPACITOR, CERAMIC 47000PF/16V
C204	1-162-926-11	s	CAPACITOR, CERAMIC 82PF/50V CH
C205	1-162-926-11	s	CAPACITOR, CERAMIC 82PF/50V CH
C206	1-162-926-11	s	CAPACITOR, CERAMIC 82PF/50V CH
C231	1-126-935-11	s	CAPACITOR, ELECT 470MF/16V
C232	1-162-927-11	s	CAPACITOR, CERAMIC 100PF/50V CH
C233	1-162-970-11	s	CAPACITOR CERAMIC 0.01MF/25V B
C234	1-162-927-11	s	CAPACITOR, CERAMIC 100PF/50V CH
C235	1-165-176-11	s	CAPACITOR, CERAMIC 47000PF/16V
C236	1-165-176-11	s	CAPACITOR, CERAMIC 47000PF/16V
C237	1-165-176-11	s	CAPACITOR, CERAMIC 47000PF/16V
C238	1-162-927-11	s	CAPACITOR, CERAMIC 100PF/50V CH
C239	1-162-926-11	s	CAPACITOR, CERAMIC 82PF/50V CH
C240	1-165-176-11	s	CAPACITOR, CERAMIC 47000PF/16V
C241	1-165-176-11	s	CAPACITOR, CERAMIC 47000PF/16V
C242	1-165-176-11	s	CAPACITOR, CERAMIC 47000PF/16V
C243	1-162-927-11	s	CAPACITOR, CERAMIC 100PF/50V CH
C244	1-126-947-11	s	CAPACITOR, ELECT 47MF/35V
C245	1-127-715-11	s	CAPACITOR, CERAMIC 0.22MF B1608
C246	1-127-573-11	s	CAPACITOR, CERAMIC 1MFB(2012)
C247	1-107-826-11	s	CAPACITOR, CHIP CERAMIC 0.1MF
C248	1-107-826-11	s	CAPACITOR, CHIP CERAMIC 0.1MF
C249	1-162-970-11	s	CAPACITOR CERAMIC 0.01MF/25V B
C250	1-162-970-11	s	CAPACITOR CERAMIC 0.01MF/25V B
C251	1-127-573-11	s	CAPACITOR, CERAMIC 1MFB(2012)
C252	1-107-826-11	s	CAPACITOR, CHIP CERAMIC 0.1MF
C253	1-107-826-11	s	CAPACITOR, CHIP CERAMIC 0.1MF
C254	1-107-826-11	s	CAPACITOR, CHIP CERAMIC 0.1MF
C255	1-107-826-11	s	CAPACITOR, CHIP CERAMIC 0.1MF
C256	1-107-826-11	s	CAPACITOR, CHIP CERAMIC 0.1MF
C257	1-127-573-11	s	CAPACITOR, CERAMIC 1MFB(2012)
C258	1-107-826-11	s	CAPACITOR, CHIP CERAMIC 0.1MF
C259	1-107-826-11	s	CAPACITOR, CHIP CERAMIC 0.1MF
C260	1-107-826-11	s	CAPACITOR, CHIP CERAMIC 0.1MF

(B BOARD)

Ref. No. or Q'ty	Part No.	SP Description
C261	1-164-005-11	s CAPACITOR, CERAMIC 0.47MF/25V
C262	1-126-947-11	s CAPACITOR, ELECT 47MF/35V
C263	1-164-005-11	s CAPACITOR, CERAMIC 0.47MF/25V
C264	1-162-970-11	s CAPACITOR, CERAMIC 0.01MF/25V B
C265	1-107-826-11	s CAPACITOR, CHIP CERAMIC 0.1MF
C266	1-162-970-11	s CAPACITOR CERAMIC 0.01MF/25V B
C267	1-162-970-11	s CAPACITOR CERAMIC 0.01MF/25V B
C268	1-126-935-11	s CAPACITOR, ELECT 470MF/16V
C269	1-126-935-11	s CAPACITOR, ELECT 470MF/16V
C270	1-162-970-11	s CAPACITOR CERAMIC 0.01MF/25V B
C271	1-126-935-11	s CAPACITOR, ELECT 470MF/16V
C273	1-162-970-11	s CAPACITOR CERAMIC 0.01MF/25V B
C274	1-162-970-11	s CAPACITOR CERAMIC 0.01MF/25V B
C275	1-162-970-11	s CAPACITOR CERAMIC 0.01MF/25V B
C276	1-162-965-11	s CAPACITOR, CERAMIC 1500PF/50V B
C277	1-162-965-11	s CAPACITOR, CERAMIC 1500PF/50V B
C278	1-162-965-11	s CAPACITOR, CERAMIC 1500PF/50V B
C279	1-162-927-11	s CAPACITOR, CERAMIC 100PF/50V CH
C280	1-162-927-11	s CAPACITOR, CERAMIC 100PF/50V CH
C281	1-162-927-11	s CAPACITOR, CERAMIC 100PF/50V CH
C282	1-115-416-11	s CAPACITOR, CERAMIC 1000PF/25V
C283	1-115-416-11	s CAPACITOR, CERAMIC 1000PF/25V
C284	1-115-416-11	s CAPACITOR, CERAMIC 1000PF/25V
C285	1-164-388-11	s CAPACITOR, CERAMIC 270PF/50V CH
C286	1-164-677-11	s CAPACITOR, CERAMIC 0.033MF/16V
C287	1-162-970-11	s CAPACITOR CERAMIC 0.01MF/25V B
C301	1-126-960-11	s CAPACITOR, ELECT 1MF/50V
C350	1-162-970-11	s CAPACITOR CERAMIC 0.01MF/25V B
C351	1-162-970-11	s CAPACITOR CERAMIC 0.01MF/25V B
C352	1-162-970-11	s CAPACITOR CERAMIC 0.01MF/25V B
C353	1-162-970-11	s CAPACITOR CERAMIC 0.01MF/25V B
C354	1-162-970-11	s CAPACITOR CERAMIC 0.01MF/25V B
C355	1-162-970-11	s CAPACITOR CERAMIC 0.01MF/25V B
C356	1-162-970-11	s CAPACITOR CERAMIC 0.01MF/25V B
C357	1-164-739-11	s CAPACITOR CERAMIC 560PF (1608)
C358	1-162-970-11	s CAPACITOR CERAMIC 0.01MF/25V B
C359	1-162-926-11	s CAPACITOR, CERAMIC 82PF/50V CH
C360	1-162-920-11	s CAPACITOR, CERAMIC 27PF/50V CH
C361	1-162-925-11	s CAPACITOR, CERAMIC 68PF/50V CH
C362	1-162-959-11	s CAPACITOR, CERAMIC 330PF/50V SL
C363	1-162-959-11	s CAPACITOR, CERAMIC 330PF/50V SL
C364	1-162-959-11	s CAPACITOR, CERAMIC 330PF/50V SL
C365	1-162-928-11	s CAPACITOR, CERAMIC 120PF/50V CH
C366	1-162-928-11	s CAPACITOR, CERAMIC 120PF/50V CH
C367	1-162-928-11	s CAPACITOR, CERAMIC 120PF/50V CH
C368	1-115-416-11	s CAPACITOR, CERAMIC 1000PF/25V
C369	1-162-970-11	s CAPACITOR CERAMIC 0.01MF/25V B
C370	1-162-927-11	s CAPACITOR, CERAMIC 100PF/50V CH
C371	1-136-159-00	s CAPACITOR, FILM 0.033MF/50V
C372	1-126-933-11	s CAPACITOR, ELECT 100MF/16V
C373	1-162-923-11	s CAPACITOR, CERAMIC 47PF/50V CH
C374	1-162-970-11	s CAPACITOR CERAMIC 0.01MF/25V B
C377	1-162-970-11	s CAPACITOR CERAMIC 0.01MF/25V B
C378	1-104-999-11	s CAPACITOR FILM 0.1MF/200V PETP
C379	1-128-772-91	s CAP, ELECT 33MF
C403	1-107-826-11	s CAPACITOR, CHIP CERAMIC 0.1MF
C404	1-107-826-11	s CAPACITOR, CHIP CERAMIC 0.1MF
C450	1-162-927-11	s CAPACITOR, CERAMIC 100PF/50V CH
C451	1-162-927-11	s CAPACITOR, CERAMIC 100PF/50V CH

(B BOARD)

Ref. No. or Q'ty	Part No.	SP Description
C452	1-126-947-11	s CAPACITOR, ELECT 47MF/35V
C453	1-162-964-11	s CAPACITOR, CERAMIC 1000PF/50V B
C454	1-162-964-11	s CAPACITOR, CERAMIC 1000PF/50V B
C455	1-162-964-11	s CAPACITOR, CERAMIC 1000PF/50V B
C456	1-162-964-11	s CAPACITOR, CERAMIC 1000PF/50V B
C457	1-162-970-11	s CAPACITOR CERAMIC 0.01MF/25V B
C458	1-162-970-11	s CAPACITOR CERAMIC 0.01MF/25V B
C459	1-162-970-11	s CAPACITOR CERAMIC 0.01MF/25V B
C460	1-162-970-11	s CAPACITOR CERAMIC 0.01MF/25V B
C461	1-162-970-11	s CAPACITOR CERAMIC 0.01MF/25V B
C462	1-162-916-11	s CAPACITOR, CERAMIC 12PF/50V CH
C463	1-162-916-11	s CAPACITOR, CERAMIC 12PF/50V CH
C464	1-162-970-11	s CAPACITOR CERAMIC 0.01MF/25V B
C465	1-125-837-11	s CAPACITOR, CHIP CERAMIC 1MF/6.3V
C466	1-162-964-11	s CAPACITOR, CERAMIC 1000PF/50V B
C467	1-107-826-11	s CAPACITOR, CHIP CERAMIC 0.1MF
C468	1-107-826-11	s CAPACITOR, CHIP CERAMIC 0.1MF
C469	1-162-970-11	s CAPACITOR CERAMIC 0.01MF/25V B
C470	1-126-947-11	s CAPACITOR, ELECT 47MF/35V
C471	1-126-964-11	s CAPACITOR, ELECT 10MF/50V
C472	1-107-826-11	s CAPACITOR, CHIP CERAMIC 0.1MF
C7201	1-162-927-11	s CAPACITOR, CERAMIC 100PF/50V CH
C7202	1-164-218-11	s CAPACITOR, CERAMIC 180PF/50V CH
C7203	1-164-730-11	s CAPACITOR, CERAMIC 1200RF (M-)
C7204	1-107-826-11	s CAPACITOR, CHIP CERAMIC 0.1MF
C7205	1-162-968-11	s CAPACITOR, CERAMIC 4700PF/50V B
C7206	1-162-927-11	s CAPACITOR, CERAMIC 100PF/50V CH
C7207	1-125-837-11	s CAPACITOR, CHIP CERAMIC 1MF/6.3V
C7208	1-164-730-11	s CAPACITOR, CERAMIC 1200RF (M-)
C7209	1-162-964-11	s CAPACITOR, CERAMIC 1000PF/50V B
C7210	1-125-837-11	s CAPACITOR, CHIP CERAMIC 1MF/6.3V
C7211	1-126-935-11	s CAPACITOR, ELECT 470MF/16V
C7212	1-107-826-11	s CAPACITOR, CHIP CERAMIC 0.1MF
CN102	1-564-515-11	o PLUG, CONNECTOR (12P)
CN103	1-564-512-11	o PLUG, CONNECTOR (9P)
CN105	1-564-511-11	o PLUG, CONNECTOR (8P)
CN106	1-564-508-11	o PLUG, CONNECTOR (5P)
CN107	1-778-005-21	o CONNECTOR, BOARD TO BOARD 20P
CN231	1-564-516-11	o PLUG, CONNECTOR (13P)
CN350	1-564-509-11	o PLUG, CONNECTOR (6P)
CN450	1-564-711-11	o PIN, CONNECTOR (9P)
CN451	1-564-522-11	o PLUG, CONNECTOR (7P) (L-TYPE)
CN452	1-564-715-11	s PIN, CONNECTOR (13P)
CN453	1-564-520-11	o PLUG, CONNECTOR (5P) (L-TYPE)
CN454	1-564-719-11	o PIN, CONNECTOR (3P)
D201	8-719-073-01	s DIODE MA111-(K8).S0
D202	8-719-073-01	s DIODE MA111-(K8).S0
D231	8-719-073-01	s DIODE MA111-(K8).S0
D233	8-719-073-01	s DIODE MA111-(K8).S0
D234	8-719-073-01	s DIODE MA111-(K8).S0
D235	8-719-073-01	s DIODE MA111-(K8).S0
D236	8-719-037-00	s DIODE RD6.2SB2-T1
D237	8-719-083-57	s DIODE UDZSTE-173.6B
D238	8-719-083-57	s DIODE UDZSTE-173.6B
D239	8-719-083-57	s DIODE UDZSTE-173.6B
D301	8-719-073-01	s DIODE MA111-(K8).S0
D350	8-719-073-01	s DIODE MA111-(K8).S0
D351	8-719-073-01	s DIODE MA111-(K8).S0

(B BOARD)

Ref. No. or Q'ty	Part No.	SP Description	
D352	8-719-073-01	s DIODE MA111-(K8).SO	
D353	8-719-073-01	s DIODE MA111-(K8).SO	
D354	8-719-901-83	s DIODE 1SS83	
D355	8-719-800-76	s DIODE 1SS226	
D356	8-719-800-76	s DIODE 1SS226	
D357	8-719-073-01	s DIODE MA111-(K8).SO	
D358	8-719-901-83	s DIODE 1SS83	
D359	8-719-800-76	s DIODE 1SS226	
D360	8-719-800-76	s DIODE 1SS226	
D361	8-719-073-01	s DIODE MA111-(K8).SO	
D362	8-719-901-83	s DIODE 1SS83	
D363	8-719-800-76	s DIODE 1SS226	
D364	8-719-800-76	s DIODE 1SS226	
D365	8-719-073-01	s DIODE MA111-(K8).SO	
D366	8-719-073-01	s DIODE MA111-(K8).SO	
D367	8-719-901-83	s DIODE 1SS83	
D368	8-719-901-83	s DIODE 1SS83	
D369	8-719-901-83	s DIODE 1SS83	
D401	8-719-801-78	s DIODE 1SS184	
D450	8-719-159-13	s DIODE RD5.1SB3-T2	(5MA)
D451	8-719-159-13	s DIODE RD5.1SB3-T2	(5MA)
D452	8-719-159-13	s DIODE RD5.1SB3-T2	(5MA)
D453	8-719-159-13	s DIODE RD5.1SB3-T2	(5MA)
D454	8-719-159-13	s DIODE RD5.1SB3-T2	(5MA)
D455	8-719-159-13	s DIODE RD5.1SB3-T2	(5MA)
D456	8-719-159-13	s DIODE RD5.1SB3-T2	(5MA)
D457	8-719-159-13	s DIODE RD5.1SB3-T2	(5MA)
D458	8-719-159-13	s DIODE RD5.1SB3-T2	(5MA)
D459	8-719-159-13	s DIODE RD5.1SB3-T2	(5MA)
D460	8-719-159-13	s DIODE RD5.1SB3-T2	(5MA)
D461	8-719-159-13	s DIODE RD5.1SB3-T2	(5MA)
D462	8-719-159-13	s DIODE RD5.1SB3-T2	(5MA)
D463	8-719-159-13	s DIODE RD5.1SB3-T2	(5MA)
D464	8-719-159-13	s DIODE RD5.1SB3-T2	(5MA)
D465	8-719-159-13	s DIODE RD5.1SB3-T2	(5MA)
D466	8-719-037-23	s DIODE RD12SB1-T1	
FL101	1-239-183-11	s FILTER, EMI	
FL102	1-239-183-11	s FILTER, EMI	
FL103	1-239-183-11	s FILTER, EMI	
FL104	1-239-899-21	s FILTER, CHIP EMI	
FL105	1-239-899-21	s FILTER, CHIP EMI	
FL106	1-239-899-21	s FILTER, CHIP EMI	
FL107	1-239-397-11	s FILTER, LOW PASS (8MHZ)	
FL108	1-239-397-11	s FILTER, LOW PASS (8MHZ)	
FL109	1-239-397-11	s FILTER, LOW PASS (8MHZ)	
FL110	1-236-071-11	s EMI FILTER	
FL111	1-236-071-11	s EMI FILTER	
FL112	1-236-071-11	s EMI FILTER	
IC102	8-759-671-94	s IC MC74HC4053AFEL	
IC104	8-752-099-05	s IC CXA2163AQ-T6	
IC105	8-759-648-48	s IC TC7W34FU(Te12R)	
IC106	8-759-710-86	s IC NJM2233BM	
IC107	8-759-710-86	s IC NJM2233BM	
IC109	8-759-367-62	s IC MC74HC157AFEL	
IC111	8-759-436-89	s IC MC141627FT	
IC112	8-759-446-66	s IC MM1113XFBE	
IC113	8-759-446-66	s IC MM1113XFBE	
IC114	8-759-446-66	s IC MM1113XFBE	

(B BOARD)

Ref. No. or Q'ty	Part No.	SP Description	
IC115	8-759-988-13	s IC LM393PS	
IC231	8-752-067-05	s IC CXA1739S	
IC232	8-759-671-94	s IC MC74HC4053AFEL	
IC233	8-759-671-94	s IC MC74HC4053AFEL	
IC301	8-759-988-13	s IC LM393PS	
IC350	8-759-482-47	s IC M62399FP (TE2)	
IC351	8-759-482-47	s IC M62399FP (TE2)	
IC352	8-759-567-08	s IC MB88141APF-ER	
IC353	8-759-242-68	s IC TC7W32F	
IC355	8-759-239-34	s IC TC74HC4538AF	
IC356	8-759-038-15	s IC MC74HC4538AF	
IC357	8-759-058-64	s IC TC7S32FU-TE85R	
IC401	8-759-058-62	s IC TC7S08FU-TE85R	
IC450	8-759-575-72	s IC M24C08-WMN6T	
IC451	6-802-786-01	s IC UPD70F3033AYGC-M12-8EU	
IC452	6-802-580-01	s IC MB90096PF-G-248-BND-ER	
IC453	8-759-582-91	s IC S-80842ANNP-ED6-T2	
IC7201	8-759-038-15	s IC MC74HC4538AF	
IC7202	8-759-038-15	s IC MC74HC4538AF	
IC7203	8-759-234-13	s IC TC4S30F	
IC7204	8-759-209-69	s IC TC4S11F	
IC7205	8-759-514-57	s IC BA7046F	
JR101	1-216-864-11	s CONDUCTOR, CHIP (1608)	
L101	1-408-619-31	s MICRO INDUCTOR 220UH	
L102	1-408-599-31	s MICRO INDUCTOR 4.7UH	
L103	1-408-599-31	s MICRO INDUCTOR 4.7UH	
L104	1-408-599-31	s MICRO INDUCTOR 4.7UH	
L105	1-408-599-31	s MICRO INDUCTOR 4.7UH	
L106	1-408-599-31	s MICRO INDUCTOR 4.7UH	
L110	1-406-665-11	s COIL CHOKE 100UH	
L230	1-408-608-31	s MICRO INDUCTOR 27UH	
L350	1-408-615-31	s MICRO INDUCTOR 100UH	
L450	1-414-119-11	s INDUCTOR (SMALL TYPE) 22UH	
L451	1-414-119-11	s INDUCTOR (SMALL TYPE) 22UH	
L452	1-414-119-11	s INDUCTOR (SMALL TYPE) 22UH	
L453	1-414-119-11	s INDUCTOR (SMALL TYPE) 22UH	
L454	1-408-615-31	s MICRO INDUCTOR 100UH	
Q101	1-801-806-11	s TRANSISTOR DTC144EKA	
Q102	1-801-806-11	s TRANSISTOR DTC144EKA	
Q103	1-801-806-11	s TRANSISTOR DTC144EKA	
Q104	8-729-026-49	s TRANSISTOR 2SA1037AK-T146-R	
Q105	8-729-026-49	s TRANSISTOR 2SA1037AK-T146-R	
Q106	8-729-026-49	s TRANSISTOR 2SA1037AK-T146-R	
Q107	8-729-026-49	s TRANSISTOR 2SA1037AK-T146-R	
Q108	8-729-026-49	s TRANSISTOR 2SA1037AK-T146-R	
Q109	8-729-026-49	s TRANSISTOR 2SA1037AK-T146-R	
Q110	8-729-026-49	s TRANSISTOR 2SA1037AK-T146-R	
Q111	8-729-026-49	s TRANSISTOR 2SA1037AK-T146-R	
Q112	8-729-026-49	s TRANSISTOR 2SA1037AK-T146-R	
Q113	8-729-120-28	s TRANSISTOR 2SC1623-L5L6	
Q114	8-729-120-28	s TRANSISTOR 2SC1623-L5L6	
Q115	8-729-120-28	s TRANSISTOR 2SC1623-L5L6	
Q116	8-729-120-28	s TRANSISTOR 2SC1623-L5L6	
Q117	1-801-806-11	s TRANSISTOR DTC144EKA	
Q118	8-729-026-49	s TRANSISTOR 2SA1037AK-T146-R	
Q119	8-729-026-49	s TRANSISTOR 2SA1037AK-T146-R	
Q120	8-729-026-49	s TRANSISTOR 2SA1037AK-T146-R	

(B BOARD)

Ref. No. or Q'ty	Part No.	SP	Description
Q124	8-729-026-49	s	TRANSISTOR 2SA1037AK-T146-R
Q125	8-729-026-49	s	TRANSISTOR 2SA1037AK-T146-R
Q126	8-729-026-49	s	TRANSISTOR 2SA1037AK-T146-R
Q130	1-801-806-11	s	TRANSISTOR DTC144EKA
Q131	8-729-026-49	s	TRANSISTOR 2SA1037AK-T146-R
Q132	8-729-026-49	s	TRANSISTOR 2SA1037AK-T146-R
Q234	1-801-806-11	s	TRANSISTOR DTC144EKA
Q235	8-729-120-28	s	TRANSISTOR 2SC1623-L5L6
Q236	8-729-026-49	s	TRANSISTOR 2SA1037AK-T146-R
Q237	8-729-026-49	s	TRANSISTOR 2SA1037AK-T146-R
Q238	8-729-026-49	s	TRANSISTOR 2SA1037AK-T146-R
Q239	8-729-120-28	s	TRANSISTOR 2SC1623-L5L6
Q240	8-729-026-49	s	TRANSISTOR 2SA1037AK-T146-R
Q241	8-729-120-28	s	TRANSISTOR 2SC1623-L5L6
Q243	8-729-120-28	s	TRANSISTOR 2SC1623-L5L6
Q244	8-729-120-28	s	TRANSISTOR 2SC1623-L5L6
Q245	8-729-120-28	s	TRANSISTOR 2SC1623-L5L6
Q246	8-729-026-49	s	TRANSISTOR 2SA1037AK-T146-R
Q247	8-729-026-49	s	TRANSISTOR 2SA1037AK-T146-R
Q248	8-729-026-49	s	TRANSISTOR 2SA1037AK-T146-R
Q249	8-729-120-28	s	TRANSISTOR 2SC1623-L5L6
Q250	8-729-120-28	s	TRANSISTOR 2SC1623-L5L6
Q251	8-729-120-28	s	TRANSISTOR 2SC1623-L5L6
Q252	8-729-026-49	s	TRANSISTOR 2SA1037AK-T146-R
Q253	8-729-026-49	s	TRANSISTOR 2SA1037AK-T146-R
Q254	8-729-026-49	s	TRANSISTOR 2SA1037AK-T146-R
Q255	8-729-120-28	s	TRANSISTOR 2SC1623-L5L6
Q256	8-729-120-28	s	TRANSISTOR 2SC1623-L5L6
Q257	8-729-120-28	s	TRANSISTOR 2SC1623-L5L6
Q258	8-729-120-28	s	TRANSISTOR 2SC1623-L5L6
Q259	8-729-120-28	s	TRANSISTOR 2SC1623-L5L6
Q260	8-729-120-28	s	TRANSISTOR 2SC1623-L5L6
Q261	8-729-026-49	s	TRANSISTOR 2SA1037AK-T146-R
Q262	8-729-026-49	s	TRANSISTOR 2SA1037AK-T146-R
Q263	8-729-026-49	s	TRANSISTOR 2SA1037AK-T146-R
Q351	8-729-326-11	s	TRANSISTOR 2SC2611
Q352	8-729-326-11	s	TRANSISTOR 2SC2611
Q353	8-729-326-11	s	TRANSISTOR 2SC2611
Q355	8-729-200-17	s	TRANSISTOR 2SA1091-0
Q356	8-729-255-12	s	TRANSISTOR 2SC2551-0
Q357	8-729-200-17	s	TRANSISTOR 2SA1091-0
Q358	8-729-255-12	s	TRANSISTOR 2SC2551-0
Q359	8-729-200-17	s	TRANSISTOR 2SA1091-0
Q360	8-729-255-12	s	TRANSISTOR 2SC2551-0
Q361	8-729-255-12	s	TRANSISTOR 2SC2551-0
Q362	8-729-255-12	s	TRANSISTOR 2SC2551-0
Q363	8-729-216-22	s	TRANSISTOR 2SA1162-G
Q364	8-729-216-22	s	TRANSISTOR 2SA1162-G
Q365	8-729-216-22	s	TRANSISTOR 2SA1162-G
Q450	1-801-806-11	s	TRANSISTOR DTC144EKA
Q451	1-801-806-11	s	TRANSISTOR DTC144EKA
Q452	1-801-806-11	s	TRANSISTOR DTC144EKA
Q453	1-801-806-11	s	TRANSISTOR DTC144EKA
Q454	1-801-806-11	s	TRANSISTOR DTC144EKA
Q455	1-801-806-11	s	TRANSISTOR DTC144EKA
Q456	1-801-806-11	s	TRANSISTOR DTC144EKA
Q457	1-801-806-11	s	TRANSISTOR DTC144EKA
Q458	1-801-806-11	s	TRANSISTOR DTC144EKA
Q459	1-801-806-11	s	TRANSISTOR DTC144EKA

(B BOARD)

Ref. No. or Q'ty	Part No.	SP	Description
Q460	8-729-027-38	s	TRANSISTOR DTA144EKA-T146
Q461	1-801-806-11	s	TRANSISTOR DTC144EKA
Q462	1-801-806-11	s	TRANSISTOR DTC144EKA
Q463	1-801-806-11	s	TRANSISTOR DTC144EKA
Q7201	1-801-806-11	s	TRANSISTOR DTC144EKA
R100	1-216-864-11	s	CONDUCTOR, CHIP (1608)
R101	1-216-809-11	s	RESISTOR, CHIP 100 1/10W 1608
R103	1-216-809-11	s	RESISTOR, CHIP 100 1/10W 1608
R105	1-216-809-11	s	RESISTOR, CHIP 100 1/10W 1608
R108	1-216-845-11	s	RESISTOR, CHIP 100K 1/10W(1608)
R109	1-216-845-11	s	RESISTOR, CHIP 100K 1/10W(1608)
R110	1-216-864-11	s	CONDUCTOR, CHIP (1608)
R111	1-216-864-11	s	CONDUCTOR, CHIP (1608)
R112	1-216-864-11	s	CONDUCTOR, CHIP (1608)
R113	1-218-881-11	s	RESISTOR, CHIP 27K 1/10W(1608)
R114	1-216-828-11	s	RESISTOR, CHIP 3.9K 1/10W 1608
R115	1-216-821-11	s	RESISTOR, CHIP 1.0K 1/10W(1608)
R116	1-216-855-11	s	RESISTOR, CHIP 680K 1/10W 1608
R117	1-216-805-11	s	RESISTOR, CHIP 47 1/10W 1608
R118	1-216-809-11	s	RESISTOR, CHIP 100 1/10W 1608
R119	1-216-805-11	s	RESISTOR, CHIP 47 1/10W 1608
R120	1-216-809-11	s	RESISTOR, CHIP 100 1/10W 1608
R121	1-216-821-11	s	RESISTOR, CHIP 1.0K 1/10W(1608)
R122	1-216-821-11	s	RESISTOR, CHIP 1.0K 1/10W(1608)
R123	1-216-821-11	s	RESISTOR, CHIP 1.0K 1/10W(1608)
R124	1-216-821-11	s	RESISTOR, CHIP 1.0K 1/10W(1608)
R125	1-216-797-11	s	RESISTOR, CHIP 10 1/10W 1608
R126	1-216-825-11	s	RESISTOR, CHIP 2.2K 1/10W 1608
R127	1-216-797-11	s	RESISTOR, CHIP 10 1/10W 1608
R128	1-216-811-11	s	RESISTOR, CHIP 150 1/16W(1608)
R129	1-216-811-11	s	RESISTOR, CHIP 150 1/16W(1608)
R130	1-216-811-11	s	RESISTOR, CHIP 150 1/16W(1608)
R131	1-216-819-11	s	RESISTOR, CHIP 680 1/10W 1608
R132	1-216-819-11	s	RESISTOR, CHIP 680 1/10W 1608
R133	1-216-819-11	s	RESISTOR, CHIP 680 1/10W 1608
R134	1-216-845-11	s	RESISTOR, CHIP 100K 1/10W(1608)
R135	1-216-830-11	s	RESISTOR, CHIP 5.6K 1/10W 1608
R136	1-216-830-11	s	RESISTOR, CHIP 5.6K 1/10W 1608
R137	1-216-830-11	s	RESISTOR, CHIP 5.6K 1/10W 1608
R138	1-216-821-11	s	RESISTOR, CHIP 1.0K 1/10W(1608)
R139	1-216-845-11	s	RESISTOR, CHIP 100K 1/10W(1608)
R140	1-216-845-11	s	RESISTOR, CHIP 100K 1/10W(1608)
R141	1-216-833-11	s	RESISTOR, CHIP 10K 1/10W (1608)
R142	1-216-845-11	s	RESISTOR, CHIP 100K 1/10W(1608)
R143	1-216-809-11	s	RESISTOR, CHIP 100 1/10W 1608
R144	1-216-833-11	s	RESISTOR, CHIP 10K 1/10W (1608)
R146	1-216-805-11	s	RESISTOR, CHIP 47 1/10W 1608
R147	1-216-845-11	s	RESISTOR, CHIP 100K 1/10W(1608)
R148	1-216-820-11	s	RESISTOR, CHIP 820 1/10W 1608
R149	1-216-820-11	s	RESISTOR, CHIP 820 1/10W 1608
R150	1-216-820-11	s	RESISTOR, CHIP 820 1/10W 1608
R151	1-216-821-11	s	RESISTOR, CHIP 1.0K 1/10W(1608)
R152	1-216-845-11	s	RESISTOR, CHIP 100K 1/10W(1608)
R153	1-216-821-11	s	RESISTOR, CHIP 1.0K 1/10W(1608)
R154	1-218-835-11	s	RESISTOR, CHIP 330 1/10W (1608)
R155	1-211-986-11	s	RESISTOR, CHIP 51 1/10W (1608)
R156	1-216-864-11	s	CONDUCTOR, CHIP (1608)
R157	1-218-838-11	s	RESISTOR, CHIP 430 1/10W (1608)
R158	1-216-817-11	s	RESISTOR, CHIP 470 1/10W 1608

(B BOARD)

Ref. No. or Q'ty	Part No.	SP Description
R159	1-216-821-11	s RESISTOR,CHIP 1.0K 1/10W(1608)
R160	1-218-886-11	s RESISTOR,CHIP 43K 1/10W (1608)
R161	1-216-821-11	s RESISTOR,CHIP 1.0K 1/10W(1608)
R162	1-216-825-11	s RESISTOR,CHIP 2.2K 1/10W 1608
R163	1-216-821-11	s RESISTOR,CHIP 1.0K 1/10W(1608)
R164	1-216-825-11	s RESISTOR,CHIP 2.2K 1/10W 1608
R165	1-216-855-11	s RESISTOR, CHIP 680K 1/10W 1608
R166	1-216-821-11	s RESISTOR,CHIP 1.0K 1/10W(1608)
R167	1-216-841-11	s RESISTOR, CHIP 47K 1/10W 1608
R169	1-216-830-11	s RESISTOR,CHIP 5.6K 1/10W 1608
R171	1-216-830-11	s RESISTOR,CHIP 5.6K 1/10W 1608
R172	1-216-821-11	s RESISTOR,CHIP 1.0K 1/10W(1608)
R173	1-216-818-11	s RESISTOR, CHIP 560 1/10W 1608
R174	1-216-817-11	s RESISTOR,CHIP 470 1/10W 1608
R175	1-216-817-11	s RESISTOR,CHIP 470 1/10W 1608
R177	1-218-838-11	s RESISTOR,CHIP 430 1/10W (1608)
R178	1-216-833-11	s RESISTOR,CHIP 10K 1/10W (1608)
R179	1-216-821-11	s RESISTOR,CHIP 1.0K 1/10W(1608)
R180	1-216-845-11	s RESISTOR,CHIP 100K 1/10W(1608)
R181	1-216-818-11	s RESISTOR, CHIP 560 1/10W 1608
R182	1-216-818-11	s RESISTOR, CHIP 560 1/10W 1608
R184	1-216-830-11	s RESISTOR,CHIP 5.6K 1/10W 1608
R185	1-216-821-11	s RESISTOR,CHIP 1.0K 1/10W(1608)
R186	1-218-867-11	s RESISTOR,CHIP 6.8K 1/10W(1608)
R187	1-218-878-11	s RESISTOR,CHIP 20K 1/10W (1608)
R188	1-216-813-11	s RESISTOR, CHIP 220 1/10W 1608
R189	1-216-817-11	s RESISTOR,CHIP 470 1/10W 1608
R190	1-216-809-11	s RESISTOR,CHIP 100 1/10W 1608
R191	1-216-821-11	s RESISTOR,CHIP 1.0K 1/10W(1608)
R192	1-216-821-11	s RESISTOR,CHIP 1.0K 1/10W(1608)
R193	1-216-821-11	s RESISTOR,CHIP 1.0K 1/10W(1608)
R194	1-216-821-11	s RESISTOR,CHIP 1.0K 1/10W(1608)
R195	1-216-833-11	s RESISTOR,CHIP 10K 1/10W (1608)
R196	1-218-838-11	s RESISTOR,CHIP 430 1/10W (1608)
R197	1-216-809-11	s RESISTOR,CHIP 100 1/10W 1608
R198	1-216-809-11	s RESISTOR,CHIP 100 1/10W 1608
R200	1-216-833-11	s RESISTOR,CHIP 10K 1/10W (1608)
R201	1-216-821-11	s RESISTOR,CHIP 1.0K 1/10W(1608)
R202	1-216-809-11	s RESISTOR,CHIP 100 1/10W 1608
R203	1-216-809-11	s RESISTOR,CHIP 100 1/10W 1608
R204	1-216-809-11	s RESISTOR,CHIP 100 1/10W 1608
R205	1-216-805-11	s RESISTOR,CHIP 47 1/10W 1608
R206	1-216-805-11	s RESISTOR,CHIP 47 1/10W 1608
R207	1-216-805-11	s RESISTOR,CHIP 47 1/10W 1608
R208	1-216-821-11	s RESISTOR,CHIP 1.0K 1/10W(1608)
R209	1-216-821-11	s RESISTOR,CHIP 1.0K 1/10W(1608)
R210	1-216-821-11	s RESISTOR,CHIP 1.0K 1/10W(1608)
R211	1-216-809-11	s RESISTOR,CHIP 100 1/10W 1608
R212	1-216-809-11	s RESISTOR,CHIP 100 1/10W 1608
R213	1-216-809-11	s RESISTOR,CHIP 100 1/10W 1608
R214	1-216-821-11	s RESISTOR,CHIP 1.0K 1/10W(1608)
R215	1-218-870-11	s RESISTOR,CHIP 9.1K 1/10W(1608)
R216	1-218-879-11	s RESISTOR,CHIP 22K 1/10W (1608)
R217	1-216-864-11	s CONDUCTOR, CHIP (1608)
R218	1-216-833-11	s RESISTOR,CHIP 10K 1/10W (1608)
R219	1-216-837-11	s RESISTOR,CHIP 22K 1/16W 1608
R220	1-216-839-11	s RESISTOR,CHIP 33K 1/10W 1608
R221	1-218-867-11	s RESISTOR,CHIP 6.8K 1/10W(1608)
R222	1-216-817-11	s RESISTOR,CHIP 470 1/10W 1608

(B BOARD)

Ref. No. or Q'ty	Part No.	SP Description
R223	1-216-829-11	s RESISTOR,CHIP 4.7K 1/10W(1608)
R224	1-216-864-11	s CONDUCTOR, CHIP (1608)
R225	1-216-814-11	s RESISTOR,CHIP 270 1/16W 1608
R229	1-216-864-11	s CONDUCTOR, CHIP (1608)
R237	1-216-809-11	s RESISTOR,CHIP 100 1/10W 1608
R238	1-218-845-11	s RESISTOR,CHIP 820 1/10W (1608)
R239	1-216-809-11	s RESISTOR,CHIP 100 1/10W 1608
R240	1-216-833-11	s RESISTOR,CHIP 10K 1/10W (1608)
R241	1-216-836-11	s RESISTOR, CHIP 18K 1/10W 1608
R242	1-216-809-11	s RESISTOR,CHIP 100 1/10W 1608
R243	1-216-809-11	s RESISTOR,CHIP 100 1/10W 1608
R244	1-216-809-11	s RESISTOR,CHIP 100 1/10W 1608
R245	1-216-809-11	s RESISTOR,CHIP 100 1/10W 1608
R246	1-216-809-11	s RESISTOR,CHIP 100 1/10W 1608
R247	1-218-853-11	s RESISTOR,CHIP 1.8K 1/10W(1608)
R248	1-218-835-11	s RESISTOR,CHIP 330 1/10W (1608)
R254	1-216-821-11	s RESISTOR,CHIP 1.0K 1/10W(1608)
R255	1-216-815-11	s RESISTOR,CHIP 330 1/10W 1608
R256	1-216-829-11	s RESISTOR,CHIP 4.7K 1/10W(1608)
R257	1-216-829-11	s RESISTOR,CHIP 4.7K 1/10W(1608)
R258	1-216-828-11	s RESISTOR, CHIP 3.9K 1/10W 1608
R259	1-216-832-11	s RESISTOR,CHIP 8.2K 1/16W 1608
R260	1-218-867-11	s RESISTOR,CHIP 6.8K 1/10W(1608)
R261	1-216-809-11	s RESISTOR,CHIP 100 1/10W 1608
R262	1-216-853-11	s RESISTOR,CHIP 470K 1/16W(1608)
R263	1-216-809-11	s RESISTOR,CHIP 100 1/10W 1608
R264	1-218-867-11	s RESISTOR,CHIP 6.8K 1/10W(1608)
R265	1-216-849-11	s RESISTOR,CHIP 220K 1/16W 1608
R266	1-216-844-11	s RESISTOR,CHIP 82K 1/16W 1608
R267	1-216-853-11	s RESISTOR,CHIP 470K 1/16W(1608)
R268	1-216-864-11	s CONDUCTOR, CHIP (1608)
R269	1-216-839-11	s RESISTOR,CHIP 33K 1/10W 1608
R270	1-216-851-11	s RESISTOR,CHIP 330K 1/16W 1608
R271	1-218-917-11	s RESISTOR,CHIP 820K 1/10W(1608)
R272	1-216-840-11	s RESISTOR,CHIP 39K 1/10W 1608
R273	1-216-864-11	s CONDUCTOR, CHIP (1608)
R274	1-216-845-11	s RESISTOR,CHIP 100K 1/10W(1608)
R275	1-216-838-11	s RESISTOR CHIP 27K 1/10W(1608)
R276	1-216-809-11	s RESISTOR,CHIP 100 1/10W 1608
R277	1-216-839-11	s RESISTOR,CHIP 33K 1/10W 1608
R278	1-216-853-11	s RESISTOR,CHIP 470K 1/16W(1608)
R279	1-218-883-11	s RESISTOR,CHIP 33K 1/10W (1608)
R280	1-216-839-11	s RESISTOR,CHIP 33K 1/10W 1608
R281	1-218-883-11	s RESISTOR,CHIP 33K 1/10W (1608)
R282	1-216-839-11	s RESISTOR,CHIP 33K 1/10W 1608
R283	1-218-883-11	s RESISTOR,CHIP 33K 1/10W (1608)
R284	1-216-839-11	s RESISTOR,CHIP 33K 1/10W 1608
R286	1-216-828-11	s RESISTOR, CHIP 3.9K 1/10W 1608
R287	1-216-828-11	s RESISTOR, CHIP 3.9K 1/10W 1608
R288	1-216-828-11	s RESISTOR, CHIP 3.9K 1/10W 1608
R291	1-216-809-11	s RESISTOR,CHIP 100 1/10W 1608
R292	1-216-833-11	s RESISTOR,CHIP 10K 1/10W (1608)
R293	1-216-841-11	s RESISTOR, CHIP 47K 1/10W 1608
R294	1-216-809-11	s RESISTOR,CHIP 100 1/10W 1608
R295	1-216-832-11	s RESISTOR,CHIP 8.2K 1/16W 1608
R296	1-218-885-11	s RESISTOR,CHIP 39K 1/10W (1608)
R297	1-216-839-11	s RESISTOR,CHIP 33K 1/10W 1608
R299	1-218-884-11	s RESISTOR,CHIP 36K 1/10W (1608)
R302	1-216-845-11	s RESISTOR,CHIP 100K 1/10W(1608)

(B BOARD)

Ref. No. or Q'ty	Part No.	SP Description
R303	1-216-809-11	s RESISTOR, CHIP 100 1/10W 1608
R304	1-216-809-11	s RESISTOR, CHIP 100 1/10W 1608
R305	1-216-809-11	s RESISTOR, CHIP 100 1/10W 1608
R306	1-216-805-11	s RESISTOR, CHIP 47 1/10W 1608
R307	1-216-805-11	s RESISTOR, CHIP 47 1/10W 1608
R308	1-216-805-11	s RESISTOR, CHIP 47 1/10W 1608
R309	1-216-821-11	s RESISTOR, CHIP 1.0K 1/10W(1608)
R310	1-216-817-11	s RESISTOR, CHIP 470 1/10W 1608
R311	1-216-817-11	s RESISTOR, CHIP 470 1/10W 1608
R312	1-216-817-11	s RESISTOR, CHIP 470 1/10W 1608
R313	1-216-821-11	s RESISTOR, CHIP 1.0K 1/10W(1608)
R314	1-216-821-11	s RESISTOR, CHIP 1.0K 1/10W(1608)
R315	1-216-821-11	s RESISTOR, CHIP 1.0K 1/10W(1608)
R316	1-216-821-11	s RESISTOR, CHIP 1.0K 1/10W(1608)
R317	1-216-821-11	s RESISTOR, CHIP 1.0K 1/10W(1608)
R318	1-216-809-11	s RESISTOR, CHIP 100 1/10W 1608
R319	1-211-981-11	s RESISTOR, CHIP 33 1/10W (1608)
R320	1-211-981-11	s RESISTOR, CHIP 33 1/10W (1608)
R321	1-216-809-11	s RESISTOR, CHIP 100 1/10W 1608
R322	1-211-981-11	s RESISTOR, CHIP 33 1/10W (1608)
R323	1-216-809-11	s RESISTOR, CHIP 100 1/10W 1608
R324	1-216-817-11	s RESISTOR, CHIP 470 1/10W 1608
R325	1-216-817-11	s RESISTOR, CHIP 470 1/10W 1608
R326	1-216-817-11	s RESISTOR, CHIP 470 1/10W 1608
R327	1-216-833-11	s RESISTOR, CHIP 10K 1/10W (1608)
R328	1-216-833-11	s RESISTOR, CHIP 10K 1/10W (1608)
R329	1-216-833-11	s RESISTOR, CHIP 10K 1/10W (1608)
R330	1-216-844-11	s RESISTOR, CHIP 82K 1/16W 1608
R331	1-216-844-11	s RESISTOR, CHIP 82K 1/16W 1608
R332	1-216-844-11	s RESISTOR, CHIP 82K 1/16W 1608
R333	1-216-821-11	s RESISTOR, CHIP 1.0K 1/10W(1608)
R334	1-216-821-11	s RESISTOR, CHIP 1.0K 1/10W(1608)
R335	1-216-829-11	s RESISTOR, CHIP 4.7K 1/10W(1608)
R336	1-216-821-11	s RESISTOR, CHIP 1.0K 1/10W(1608)
R337	1-216-817-11	s RESISTOR, CHIP 470 1/10W 1608
R338	1-216-829-11	s RESISTOR, CHIP 4.7K 1/10W(1608)
R339	1-216-817-11	s RESISTOR, CHIP 470 1/10W 1608
R340	1-216-817-11	s RESISTOR, CHIP 470 1/10W 1608
R341	1-216-829-11	s RESISTOR, CHIP 4.7K 1/10W(1608)
R342	1-216-821-11	s RESISTOR, CHIP 1.0K 1/10W(1608)
R343	1-216-821-11	s RESISTOR, CHIP 1.0K 1/10W(1608)
R344	1-216-821-11	s RESISTOR, CHIP 1.0K 1/10W(1608)
R345	1-216-833-11	s RESISTOR, CHIP 10K 1/10W (1608)
R346	1-216-849-11	s RESISTOR, CHIP 220K 1/16W 1608
R347	1-216-841-11	s RESISTOR, CHIP 47K 1/10W 1608
R348	1-216-861-11	s RESISTOR, CHIP 2.2M 1/16W 1608
R350	1-216-830-11	s RESISTOR, CHIP 5.6K 1/10W 1608
R351	1-216-838-11	s RESISTOR, CHIP 27K 1/10W(1608)
R352	1-216-827-11	s RESISTOR, CHIP 3.3K 1/10W 1608
R353	1-216-864-11	s CONDUCTOR, CHIP (1608)
R354	1-216-797-11	s RESISTOR, CHIP 10 1/10W 1608
R355	1-216-797-11	s RESISTOR, CHIP 10 1/10W 1608
R356	1-216-832-11	s RESISTOR, CHIP 8.2K 1/16W 1608
R357	1-216-862-11	s RESISTOR, CHIP 2.7M 1/16W 1608
R358	1-216-832-11	s RESISTOR, CHIP 8.2K 1/16W 1608
R359	1-216-862-11	s RESISTOR, CHIP 2.7M 1/16W 1608
R360	1-216-862-11	s RESISTOR, CHIP 2.7M 1/16W 1608
R361	1-216-832-11	s RESISTOR, CHIP 8.2K 1/16W 1608
R362	1-216-862-11	s RESISTOR, CHIP 2.7M 1/16W 1608

(B BOARD)

Ref. No. or Q'ty	Part No.	SP Description
R363	1-216-832-11	s RESISTOR, CHIP 8.2K 1/16W 1608
R364	1-216-797-11	s RESISTOR, CHIP 10 1/10W 1608
R365	1-216-797-11	s RESISTOR, CHIP 10 1/10W 1608
R366	1-216-832-11	s RESISTOR, CHIP 8.2K 1/16W 1608
R367	1-216-862-11	s RESISTOR, CHIP 2.7M 1/16W 1608
R368	1-216-832-11	s RESISTOR, CHIP 8.2K 1/16W 1608
R369	1-216-862-11	s RESISTOR, CHIP 2.7M 1/16W 1608
R370	1-216-797-11	s RESISTOR, CHIP 10 1/10W 1608
R371	1-218-889-11	s RESISTOR, CHIP 56K 1/10W(1608)
R372	1-216-797-11	s RESISTOR, CHIP 10 1/10W 1608
R374	1-216-825-11	s RESISTOR, CHIP 2.2K 1/10W 1608
R375	1-218-885-11	s RESISTOR, CHIP 39K 1/10W (1608)
R376	1-218-871-11	s RESISTOR, CHIP 10K 1/10W (1608)
R377	1-216-821-11	s RESISTOR, CHIP 1.0K 1/10W(1608)
R380	1-216-864-11	s CONDUCTOR, CHIP (1608)
R382	1-216-809-11	s RESISTOR, CHIP 100 1/10W 1608
R383	1-216-809-11	s RESISTOR, CHIP 100 1/10W 1608
R384	1-216-809-11	s RESISTOR, CHIP 100 1/10W 1608
R385	1-218-837-11	s RESISTOR, CHIP 390 1/10W (1608)
R386	1-218-837-11	s RESISTOR, CHIP 390 1/10W (1608)
R387	1-218-835-11	s RESISTOR, CHIP 330 1/10W (1608)
R388	1-216-821-11	s RESISTOR, CHIP 1.0K 1/10W(1608)
R389	1-216-821-11	s RESISTOR, CHIP 1.0K 1/10W(1608)
R390	1-218-869-11	s RESISTOR, CHIP 8.2K 1/10W(1608)
R391	1-218-864-11	s RESISTOR, CHIP 5.1K 1/10W(1608)
R392	1-218-869-11	s RESISTOR, CHIP 8.2K 1/10W(1608)
R393	1-218-864-11	s RESISTOR, CHIP 5.1K 1/10W(1608)
R394	1-218-869-11	s RESISTOR, CHIP 8.2K 1/10W(1608)
R395	1-218-864-11	s RESISTOR, CHIP 5.1K 1/10W(1608)
R396	1-218-871-11	s RESISTOR, CHIP 10K 1/10W (1608)
R398	1-216-864-11	s CONDUCTOR, CHIP (1608)
R400	1-216-825-11	s RESISTOR, CHIP 2.2K 1/10W 1608
R402	1-215-876-00	s RESISTOR, METAL FILM 15K/1W
R403	1-216-805-11	s RESISTOR, CHIP 47 1/10W 1608
R405	1-216-821-11	s RESISTOR, CHIP 1.0K 1/10W(1608)
R406	1-218-873-11	s RESISTOR, CHIP 12K 1/10W (1608)
R407	1-216-853-11	s RESISTOR, CHIP 470K 1/16W(1608)
R408	1-249-419-11	s RESISTOR, CARBON 1.5K 1/4W
R409	1-216-811-11	s RESISTOR, CHIP 150 1/16W(1608)
R410	1-216-811-11	s RESISTOR, CHIP 150 1/16W(1608)
R411	1-249-421-11	s RESISTOR, CARBON 2.2K 1/4W
R412	1-218-891-11	s RESISTOR, CHIP 68K 1/10W (1608)
R413	1-216-864-11	s CONDUCTOR, CHIP (1608)
R414	1-216-821-11	s RESISTOR, CHIP 1.0K 1/10W(1608)
R415	1-216-825-11	s RESISTOR, CHIP 2.2K 1/10W 1608
R416	1-215-876-00	s RESISTOR, METAL FILM 15K/1W
R418	1-249-419-11	s RESISTOR, CARBON 1.5K 1/4W
R419	1-216-811-11	s RESISTOR, CHIP 150 1/16W(1608)
R420	1-216-811-11	s RESISTOR, CHIP 150 1/16W(1608)
R421	1-249-421-11	s RESISTOR, CARBON 2.2K 1/4W
R422	1-216-864-11	s CONDUCTOR, CHIP (1608)
R423	1-218-885-11	s RESISTOR, CHIP 39K 1/10W (1608)
R424	1-216-825-11	s RESISTOR, CHIP 2.2K 1/10W 1608
R426	1-215-876-00	s RESISTOR, METAL FILM 15K/1W
R427	1-249-419-11	s RESISTOR, CARBON 1.5K 1/4W
R428	1-216-811-11	s RESISTOR, CHIP 150 1/16W(1608)
R429	1-216-811-11	s RESISTOR, CHIP 150 1/16W(1608)
R430	1-249-421-11	s RESISTOR, CARBON 2.2K 1/4W
R431	1-216-864-11	s CONDUCTOR, CHIP (1608)

(B BOARD)

Ref. No. or Q'ty	Part No.	SP Description
R556	1-216-797-11	s RESISTOR,CHIP 10 1/10W 1608
R557	1-216-797-11	s RESISTOR,CHIP 10 1/10W 1608
R558	1-216-797-11	s RESISTOR,CHIP 10 1/10W 1608
R559	1-216-797-11	s RESISTOR,CHIP 10 1/10W 1608
R561	1-216-864-11	s CONDUCTOR, CHIP (1608)
R562	1-216-833-11	s RESISTOR,CHIP 10K 1/10W (1608)
R563	1-216-809-11	s RESISTOR,CHIP 100 1/10W 1608
R564	1-216-809-11	s RESISTOR,CHIP 100 1/10W 1608
R565	1-216-809-11	s RESISTOR,CHIP 100 1/10W 1608
R569	1-216-825-11	s RESISTOR,CHIP 2.2K 1/10W 1608
R570	1-216-825-11	s RESISTOR,CHIP 2.2K 1/10W 1608
R571	1-216-825-11	s RESISTOR,CHIP 2.2K 1/10W 1608
R575	1-218-831-11	s RESISTOR, CHIP 220 1/10W(1608)
R576	1-218-843-11	s RESISTOR,CHIP 680 1/10W (1608)
R577	1-216-818-11	s RESISTOR, CHIP 560 1/10W 1608
R578	1-216-813-11	s RESISTOR, CHIP 220 1/10W 1608
R579	1-216-821-11	s RESISTOR,CHIP 1.0K 1/10W(1608)
R580	1-216-821-11	s RESISTOR,CHIP 1.0K 1/10W(1608)
R581	1-216-821-11	s RESISTOR,CHIP 1.0K 1/10W(1608)
R582	1-216-813-11	s RESISTOR, CHIP 220 1/10W 1608
R583	1-216-809-11	s RESISTOR,CHIP 100 1/10W 1608
R584	1-216-864-11	s CONDUCTOR, CHIP (1608)
R585	1-216-864-11	s CONDUCTOR, CHIP (1608)
R1505	1-216-821-11	s RESISTOR,CHIP 1.0K 1/10W(1608)
R1506	1-216-821-11	s RESISTOR,CHIP 1.0K 1/10W(1608)
R1507	1-216-821-11	s RESISTOR,CHIP 1.0K 1/10W(1608)
R1511	1-216-821-11	s RESISTOR,CHIP 1.0K 1/10W(1608)
R7201	1-218-879-11	s RESISTOR,CHIP 22K 1/10W (1608)
R7202	1-218-880-11	s RESISTOR,CHIP 24K 1/10W (1608)
R7203	1-218-883-11	s RESISTOR,CHIP 33K 1/10W (1608)
R7204	1-218-889-11	s RESISTOR,CHIP 56K 1/10W(1608)
R7206	1-216-829-11	s RESISTOR,CHIP 4.7K 1/10W(1608)
R7207	1-216-823-11	s RESISTOR, CHIP 1.5K 1/10W
R7208	1-216-853-11	s RESISTOR,CHIP 470K 1/16W(1608)
R7209	1-218-743-11	s RESISTOR,CHIP 130K 1/16W(1608)
R7210	1-216-837-11	s RESISTOR,CHIP 22K 1/16W 1608
R7211	1-216-853-11	s RESISTOR,CHIP 470K 1/16W(1608)
R7212	1-216-815-11	s RESISTOR,CHIP 330 1/10W 1608
R7220	1-218-892-11	s RESISTOR,CHIP 75K 1/10W (1608)
S450	1-771-795-11	s SWITCH, SLIDE
X101	1-781-914-21	s VIBRATOR, CRYSTAL (16.2MHz)
X450	1-767-467-11	s VIBRATOR, CRYSTAL (16.9344MHz)

C BOARD

Ref. No. or Q'ty	Part No.	SP Description
1pc	A-1401-775-A	s MOUNTED CIRCUIT BOARD, C
C701	1-104-574-11	s CAPACITOR,CERAMIC 4700PF/2KDC
C710	1-161-830-00	s CAPACITOR,CERAMIC; 4700PF/500V
CN701	1-564-509-11	o PLUG,CONNECTOR (6P)
CN702	1-508-784-00	o 1P PLUG
CN703	1-564-508-11	o PLUG,CONNECTOR (5P)
J701	1-251-244-11	s SOCKET,CRT
L701	1-410-668-11	s MICRO INDUCTOR
R701	1-202-822-00	s RESISTOR, SOLID 2.2K 1/2W
R702	1-202-822-00	s RESISTOR, SOLID 2.2K 1/2W
R703	1-202-822-00	s RESISTOR, SOLID 2.2K 1/2W
R704	1-202-838-00	s RESISTOR,SOLID 100K 1/2W
R706	1-202-842-11	s RESISTOR,SOLID 220K 1/2W
R707	1-202-838-00	s RESISTOR,SOLID 100K 1/2W
RV701	1-230-164-00	s RESISTOR,ADJ,METAL GLAZE 55M

D BOARD

Ref. No. or Q'ty	Part No.	SP Description
1pc	A-1300-859-A	s MOUNTED CIRCUIT BOARD, D
6pcs	4-382-854-01	s SCREW +PSW M3X8 (EP-FE/ZN/CM2)
3pcs	4-032-770-81	o HEAT SINK, V-OUT(Q513, IC1503, IC1504)
C501	1-107-826-11	s CAPACITOR, CHIP CERAMIC 0.1MF
C502	1-126-935-11	s CAPACITOR, ELECT 470MF/16V
C503	1-162-967-11	s CAPACITOR, CERAMIC 3300PF/50V B
C504	1-126-935-11	s CAPACITOR, ELECT 470MF/16V
C505	1-164-230-11	s CAPACITOR, CERAMIC 220PF/50V
C506	1-107-826-11	s CAPACITOR, CHIP CERAMIC 0.1MF
C507	1-126-935-11	s CAPACITOR, ELECT 470MF/16V
C508	1-107-826-11	s CAPACITOR, CHIP CERAMIC 0.1MF
C509	1-128-551-11	s CAPACITOR ELECT 22MF/63V
C510	1-136-495-11	s CAPACITOR, FILM 0.068MF/50V
C511	1-107-713-11	s CAPACITOR ELECT 4.7MF/50V(BP)
C512	1-125-889-11	s CAPACITOR, C.CERAMIC 2.2MF
C513	1-162-964-11	s CAPACITOR, CERAMIC 1000PF/50V B
C514	1-136-171-00	s CAPACITOR, FILM 0.33MF/50V
C515	1-126-964-11	s CAPACITOR, ELECT 10MF/50V
C516	1-107-826-11	s CAPACITOR, CHIP CERAMIC 0.1MF
C517	1-128-551-11	s CAPACITOR ELECT 22MF/63V
C518	1-104-665-11	s CAPACITOR, ELECT 100MF/25V
C519	1-162-970-11	s CAPACITOR CERAMIC 0.01MF/25V B
C520	1-104-665-11	s CAPACITOR, ELECT 100MF/25V
C521	1-126-941-11	s CAPACITOR, ELECT 470MF/25V
C522	1-107-826-11	s CAPACITOR, CHIP CERAMIC 0.1MF
C523	1-137-194-11	s CAPACITOR FILM 0.47MF/50V
C524	1-107-826-11	s CAPACITOR, CHIP CERAMIC 0.1MF
C525	1-126-933-11	s CAPACITOR, ELECT 100MF/16V
C526	1-107-826-11	s CAPACITOR, CHIP CERAMIC 0.1MF
C527	1-162-970-11	s CAPACITOR CERAMIC 0.01MF/25V B
C528	1-126-933-11	s CAPACITOR, ELECT 100MF/16V
C529	1-107-697-11	s CAPACITOR ELECT 220MF/16V(BP)
C530	1-162-970-11	s CAPACITOR CERAMIC 0.01MF/25V B
C531	1-135-834-11	s CAPACITOR, CERAMIC 2200000PF
C532	1-164-227-11	s CAPACITOR, CERAMIC 0.022MF/25V
C533	1-164-218-11	s CAPACITOR, CERAMIC 180PF/50V CH
C534	1-164-392-11	s CAPACITOR CERAMIC 390PF/50V CH
C535	1-162-927-11	s CAPACITOR, CERAMIC 100PF/50V CH
C536	1-107-826-11	s CAPACITOR, CHIP CERAMIC 0.1MF
C537	1-164-227-11	s CAPACITOR, CERAMIC 0.022MF/25V
C538	1-162-318-11	s CAPACITOR, CERAMIC 1000PF/500V
C539	1-126-972-11	s CAPACITOR, ELECT 1000MF/50V
C540	1-162-927-11	s CAPACITOR, CERAMIC 100PF/50V CH
C541	1-126-965-11	s CAPACITOR, ELECT 22MF/50V
C542	1-162-970-11	s CAPACITOR CERAMIC 0.01MF/25V B
C543	1-163-021-91	s CAPACITOR, CERAMIC 0.01MF/50V
C544	1-127-760-11	s CAPACITOR, CERAMIC 4.7MF/6.3V
C545	1-126-971-11	s CAPACITOR ELECT 470MF/50V
C546	1-126-967-11	s CAPACITOR, ELECT 47MF/50V
C547	1-126-964-11	s CAPACITOR, ELECT 10MF/50V
C548	1-126-964-11	s CAPACITOR, ELECT 10MF/50V
C549	1-126-969-11	s CAPACITOR, ELECT 220MF/50V
C550	1-162-969-11	s CAPACITOR, CERAMIC 6800PF/25V B
C551	1-162-970-11	s CAPACITOR CERAMIC 0.01MF/25V B
C552	1-126-972-11	s CAPACITOR, ELECT 1000MF/50V
C553	1-128-551-11	s CAPACITOR ELECT 22MF/63V
C554	1-126-968-11	s CAPACITOR, ELECT 100MF/50V
C555	1-126-947-11	s CAPACITOR, ELECT 47MF/35V

(D BOARD)

Ref. No. or Q'ty	Part No.	SP Description
C556	1-130-777-00	s CAPACITOR FILM 0.1MF/100V
C557	1-129-767-61	s CAP, PP FILM 0.068MF
C558	1-126-943-11	s CAPACITOR, ELECT 2200MF/25V
C559	1-162-970-11	s CAPACITOR CERAMIC 0.01MF/25V B
C560	1-126-967-11	s CAPACITOR, ELECT 47MF/50V
C561	1-117-675-21	s CAP, PP FILM (S) 2.2MF
C562	1-126-963-11	s CAPACITOR, ELECT 4.7MF/50V
C563	1-126-947-11	s CAPACITOR, ELECT 47MF/35V
C564	1-125-889-11	s CAPACITOR, C.CERAMIC 2.2MF
C565	1-162-970-11	s CAPACITOR CERAMIC 0.01MF/25V B
C566	1-126-947-11	s CAPACITOR, ELECT 47MF/35V
C567	1-127-760-11	s CAPACITOR, CERAMIC 4.7MF/6.3V
C568	1-162-927-11	s CAPACITOR, CERAMIC 100PF/50V CH
C569	1-164-227-11	s CAPACITOR, CERAMIC 0.022MF/25V
C570	1-126-964-11	s CAPACITOR, ELECT 10MF/50V
C1501	1-107-826-11	s CAPACITOR, CHIP CERAMIC 0.1MF
C1502	1-126-942-61	s CAPACITOR, ELECT 1000MF/25V
C1503	1-162-970-11	s CAPACITOR CERAMIC 0.01MF/25V B
C1504	1-126-767-11	s CAPACITOR, ELECT 1000MF/16V
C1505	1-162-970-11	s CAPACITOR CERAMIC 0.01MF/25V B
C1506	1-126-767-11	s CAPACITOR, ELECT 1000MF/16V
C1507	1-126-934-11	s CAPACITOR, ELECT 220MF/16V
C1508	1-162-970-11	s CAPACITOR CERAMIC 0.01MF/25V B
C1509	1-162-970-11	s CAPACITOR CERAMIC 0.01MF/25V B
C1510	1-164-227-11	s CAPACITOR, CERAMIC 0.022MF/25V
C1511	1-135-834-11	s CAPACITOR, CERAMIC 2200000PF
C1512	1-164-392-11	s CAPACITOR CERAMIC 390PF/50V CH
C1513	1-162-927-11	s CAPACITOR, CERAMIC 100PF/50V CH
C1514	1-162-927-11	s CAPACITOR, CERAMIC 100PF/50V CH
C1515	1-126-965-11	s CAPACITOR, ELECT 22MF/50V
C1516	1-164-227-11	s CAPACITOR, CERAMIC 0.022MF/25V
C1517	1-162-970-11	s CAPACITOR CERAMIC 0.01MF/25V B
C1518	1-127-760-11	s CAPACITOR, CERAMIC 4.7MF/6.3V
C1519	1-115-156-11	s CAPACITOR, CERAMIC 1MF/10V(1608)
C1520	1-107-826-11	s CAPACITOR, CHIP CERAMIC 0.1MF
C1521	1-107-826-11	s CAPACITOR, CHIP CERAMIC 0.1MF
C1522	1-126-942-61	s CAPACITOR, ELECT 1000MF/25V
C1523	1-126-942-61	s CAPACITOR, ELECT 1000MF/25V
C1524	1-162-970-11	s CAPACITOR CERAMIC 0.01MF/25V B
C1525	1-162-970-11	s CAPACITOR CERAMIC 0.01MF/25V B
C1526	1-126-927-11	s CAPACITOR, ELECT 2200MF/10V
C1527	1-162-970-11	s CAPACITOR CERAMIC 0.01MF/25V B
C1528	1-126-927-11	s CAPACITOR, ELECT 2200MF/10V
C1529	1-162-970-11	s CAPACITOR CERAMIC 0.01MF/25V B
C1530	1-126-934-11	s CAPACITOR, ELECT 220MF/16V
C1531	1-126-935-11	s CAPACITOR, ELECT 470MF/16V
C1532	1-126-934-11	s CAPACITOR, ELECT 220MF/16V
C1533	1-162-970-11	s CAPACITOR CERAMIC 0.01MF/25V B
C1534	1-126-964-11	s CAPACITOR, ELECT 10MF/50V
C1535	1-162-970-11	s CAPACITOR CERAMIC 0.01MF/25V B
C1536	1-127-760-11	s CAPACITOR, CERAMIC 4.7MF/6.3V
C1537	1-164-227-11	s CAPACITOR, CERAMIC 0.022MF/25V
C1538	1-126-964-11	s CAPACITOR, ELECT 10MF/50V
C1539	1-126-933-11	s CAPACITOR, ELECT 100MF/16V
C1540	1-126-933-11	s CAPACITOR, ELECT 100MF/16V
C1542	1-126-964-11	s CAPACITOR, ELECT 10MF/50V
C1543	1-126-942-61	s CAPACITOR, ELECT 1000MF/25V
C1544	1-126-961-11	s CAPACITOR, ELECT 2.2MF/50V
C1545	1-162-970-11	s CAPACITOR CERAMIC 0.01MF/25V B

(D BOARD)

Ref. No. or Q'ty	Part No.	SP Description
C1546	1-126-964-11	s CAPACITOR, ELECT 10MF/50V
C1547	1-126-964-11	s CAPACITOR, ELECT 10MF/50V
C1548	1-126-964-11	s CAPACITOR, ELECT 10MF/50V
C1549	1-162-970-11	s CAPACITOR CERAMIC 0.01MF/25V B
C1550	1-162-970-11	s CAPACITOR CERAMIC 0.01MF/25V B
C1551	1-107-826-11	s CAPACITOR,CHIP CERAMIC 0.1MF
C1552	1-126-964-11	s CAPACITOR, ELECT 10MF/50V
C1553	1-126-935-11	s CAPACITOR, ELECT 470MF/16V
C1554	1-126-964-11	s CAPACITOR, ELECT 10MF/50V
C1555	1-126-964-11	s CAPACITOR, ELECT 10MF/50V
C1556	1-126-963-11	s CAPACITOR, ELECT 4.7MF/50V
C1557	1-126-963-11	s CAPACITOR, ELECT 4.7MF/50V
C1558	1-162-968-11	s CAPACITOR, CERAMIC 4700PF/50V B
C1559	1-126-964-11	s CAPACITOR, ELECT 10MF/50V
C1560	1-126-963-11	s CAPACITOR, ELECT 4.7MF/50V
C1561	1-106-359-00	s CAPACITOR FILM 0.0047MF/200V
C1562	1-126-767-11	s CAPACITOR, ELECT 1000MF/16V
C1563	1-104-665-11	s CAPACITOR, ELECT 100MF/25V
C1564	1-104-665-11	s CAPACITOR, ELECT 100MF/25V
C1565	1-126-947-11	s CAPACITOR, ELECT 47MF/35V
C1566	1-126-947-11	s CAPACITOR, ELECT 47MF/35V
C1567	1-162-970-11	s CAPACITOR CERAMIC 0.01MF/25V B
C1568	1-126-963-11	s CAPACITOR, ELECT 4.7MF/50V
C1569	1-162-970-11	s CAPACITOR CERAMIC 0.01MF/25V B
C1570	1-107-826-11	s CAPACITOR,CHIP CERAMIC 0.1MF
C1571	1-107-826-11	s CAPACITOR,CHIP CERAMIC 0.1MF
C1572	1-126-947-11	s CAPACITOR, ELECT 47MF/35V
C1573	1-126-964-11	s CAPACITOR, ELECT 10MF/50V
C1574	1-126-964-11	s CAPACITOR, ELECT 10MF/50V
C1575	1-165-176-11	s CAPACITOR, CERAMIC 47000PF/16V
C1576	1-125-891-11	s CAPACITOR CERAMIC 0.47MF/10V
C1577	1-137-150-11	s CAPACITOR, FILM 0.01MF/100V (PP)
C1578	1-137-150-11	s CAPACITOR, FILM 0.01MF/100V (PP)
C1579	1-126-963-11	s CAPACITOR, ELECT 4.7MF/50V
C1580	1-126-964-11	s CAPACITOR, ELECT 10MF/50V
C1581	1-164-343-11	s CAPACITOR,CHIP CERAMIC 0.056MF
C1582	1-162-970-11	s CAPACITOR CERAMIC 0.01MF/25V B
C1583	1-107-826-11	s CAPACITOR,CHIP CERAMIC 0.1MF
C1584	1-107-826-11	s CAPACITOR,CHIP CERAMIC 0.1MF
C1585	1-164-343-11	s CAPACITOR,CHIP CERAMIC 0.056MF
C1586	1-107-826-11	s CAPACITOR,CHIP CERAMIC 0.1MF
C1587	1-107-826-11	s CAPACITOR,CHIP CERAMIC 0.1MF
C1588	1-126-964-11	s CAPACITOR, ELECT 10MF/50V
C1589	1-107-648-91	s CAPACITOR ELECT 100MF/200V
C1590	1-107-652-11	s CAPACITOR ELECT 10MF/250V
C1591	1-107-652-11	s CAPACITOR ELECT 10MF/250V
CN501	1-564-516-11	o PLUG, CONNECTOR (13P)
CN502	1-564-596-11	o PLUG, CONNECTOR (15P)
CN1501	1-564-515-11	o PLUG, CONNECTOR (12P)
CN1502	1-785-294-11	s PIN, CONNECTOR (PC BOARD) 3P
CN1503	1-691-960-11	o PIN, CONNECTOR (PC BOARD) 3P
CN1504	1-564-506-11	o PLUG, CONNECTOR (3P)
CN1505	1-764-101-11	s PIN, CONNECTOR (PC BOARD) 2P
CN1506	1-564-506-11	o PLUG, CONNECTOR (3P)
CN1507	1-564-508-11	o PLUG, CONNECTOR (5P)
CN1508	1-691-960-11	o PIN, CONNECTOR (PC BOARD) 3P
CN1509	1-695-915-11	s TAB (CONTACT)

(D BOARD)

Ref. No. or Q'ty	Part No.	SP Description
D501	8-719-050-84	s DIODE RB441Q-40T-77
D502	8-719-033-52	s DIODE RD5.1SB1-T1
D503	8-719-073-01	s DIODE MA111-(K8).S0
D504	8-719-073-01	s DIODE MA111-(K8).S0
D505	8-719-058-38	s DIODE FMN-G12S
D506	8-719-073-01	s DIODE MA111-(K8).S0
D507	8-719-073-01	s DIODE MA111-(K8).S0
D508	8-719-073-01	s DIODE MA111-(K8).S0
D509	8-719-037-00	s DIODE RD6.2SB2-T1
D510	8-719-908-03	s DIODE GP08D
D511	8-719-037-23	s DIODE RD12SB1-T1
D512	8-719-159-12	s DIODE RD5.1SB2-T2
D513	8-719-073-01	s DIODE MA111-(K8).S0
D514	8-719-073-01	s DIODE MA111-(K8).S0
D515	8-719-800-76	s DIODE 1SS226
D516	8-719-073-01	s DIODE MA111-(K8).S0
D517	8-719-073-01	s DIODE MA111-(K8).S0
D518	8-719-073-01	s DIODE MA111-(K8).S0
D519	8-719-073-01	s DIODE MA111-(K8).S0
D1501	8-719-037-38	s DIODE RD18SB1-T1
D1502	8-719-059-22	s DIODE NSQ03A06-TE16L
D1503	8-719-059-22	s DIODE NSQ03A06-TE16L
D1504	8-719-037-39	s DIODE RD18SB2-T1
D1505	8-719-037-39	s DIODE RD18SB2-T1
D1506	8-719-059-22	s DIODE NSQ03A06-TE16L
D1507	8-719-059-22	s DIODE NSQ03A06-TE16L
D1510	8-719-073-01	s DIODE MA111-(K8).S0
D1511	8-719-073-01	s DIODE MA111-(K8).S0
D1512	8-719-033-52	s DIODE RD5.1SB1-T1
D1513	8-719-801-78	s DIODE 1SS184
D1514	8-719-073-01	s DIODE MA111-(K8).S0
D1515	8-719-158-40	s DIODE RD10SB1 (ZENER)
D1516	8-719-158-09	s DIODE RD4.7SB2
D1517	8-719-158-53	s DIODE RD13SB2
D1518	8-719-073-01	s DIODE MA111-(K8).S0
D1519	8-719-073-01	s DIODE MA111-(K8).S0
D1520	8-719-037-47	s DIODE RD22SB2-T1
D1521	8-719-073-01	s DIODE MA111-(K8).S0
D1522	8-719-073-01	s DIODE MA111-(K8).S0
D1523	8-719-073-01	s DIODE MA111-(K8).S0
D1524	8-719-037-39	s DIODE RD18SB2-T1
D1525	8-719-073-01	s DIODE MA111-(K8).S0
D1526	8-719-989-21	s DIODE SC311-6-TE12RA
D1527	8-719-073-01	s DIODE MA111-(K8).S0
F1501	Δ 1-576-048-11	s FUSE, GLASS 10A/125V (20MM)
F1502	Δ 1-576-048-11	s FUSE, GLASS 10A/125V (20MM)
F1503	Δ 1-576-048-11	s FUSE, GLASS 10A/125V (20MM)
FH1	1-533-223-11	s CLIP, FUSE
FH2	1-533-223-11	s CLIP, FUSE
FH3	1-533-223-11	s CLIP, FUSE
FH4	1-533-223-11	s CLIP, FUSE
FH5	1-533-223-11	s CLIP, FUSE
FH6	1-533-223-11	s CLIP, FUSE
IC501	8-759-502-80	s IC LM358M
IC502	8-759-594-40	s IC CXA8071CP
IC503	8-759-701-75	s IC NJM7805FA
IC504	8-752-053-21	s IC CXA1211M
IC505	8-759-937-36	s IC TL1451ACNS

(D BOARD)

Ref. No. or Q'ty	Part No.	SP Description
IC506	8-759-339-59	s IC TDA8177
IC1501	8-759-937-36	s IC TL1451ACNS
IC1503	8-759-450-47	s IC BA05T
IC1504	8-759-450-47	s IC BA05T
IC1506	8-759-510-73	s IC BA10393F-E2
IC1507	8-759-420-04	s IC AN5265
IC1508	8-759-140-85	s IC UPC1093J
IC1509	8-759-502-80	s IC LM358M
IC1510	8-759-914-04	s IC TL494CNS
IC1511	8-759-185-47	s IC IR2112
L501	1-410-476-11	s MICRO INDUCTOR 33UH
L502	1-424-973-11	s COIL, CHOKE (OH-0322)
L503	1-406-661-11	s COIL CHOKE 22UH
L504	1-406-661-11	s COIL CHOKE 22UH
L505	1-406-980-61	s COIL, CHOKE 330UH
L506	1-419-397-11	s COIL, CHOKE
L507	1-406-660-41	s COIL, CHOKE 15UH
L508	1-406-660-41	s COIL, CHOKE 15UH
L1501	1-419-396-11	s COIL, CHOKE
L1502	1-406-665-11	s COIL CHOKE 100UH
L1503	1-419-397-11	s COIL, CHOKE
Q501	1-801-806-11	s TRANSISTOR DTC144EKA
Q502	8-729-120-28	s TRANSISTOR 2SC1623-L5L6
Q503	8-729-027-43	s TRANSISTOR DTC114EKA-T146
Q504	8-729-026-49	s TRANSISTOR 2SA1037AK-T146-R
Q505	8-729-033-24	s TRANSISTOR DTC114GKAT146
Q506	1-801-806-11	s TRANSISTOR DTC144EKA
Q507	8-729-026-49	s TRANSISTOR 2SA1037AK-T146-R
Q508	8-729-140-96	s TRANSISTOR 2SD774-34
Q509	8-729-026-49	s TRANSISTOR 2SA1037AK-T146-R
Q510	6-550-021-01	s TRANSISTOR 2SK3148-01
Q511	8-729-026-49	s TRANSISTOR 2SA1037AK-T146-R
Q512	8-729-120-28	s TRANSISTOR 2SC1623-L5L6
Q513	8-729-313-42	s TRANSISTOR 2SD1134
Q514	8-729-422-33	s TRANSISTOR 2SD601A-Q-TX
Q515	8-729-422-33	s TRANSISTOR 2SD601A-Q-TX
Q516	8-729-216-22	s TRANSISTOR 2SA1162-G
Q517	8-729-120-28	s TRANSISTOR 2SC1623-L5L6
Q518	8-729-027-43	s TRANSISTOR DTC114EKA-T146
Q519	8-729-027-43	s TRANSISTOR DTC114EKA-T146
Q520	8-729-027-43	s TRANSISTOR DTC114EKA-T146
Q521	8-729-120-28	s TRANSISTOR 2SC1623-L5L6
Q1501	8-729-120-28	s TRANSISTOR 2SC1623-L5L6
Q1502	8-729-019-85	s TRANSISTOR 2SC3392-5-TB
Q1503	8-729-824-24	s TRANSISTOR 2SA1338-5-TB
Q1504	8-729-041-37	s TRANSISTOR 2SJ377 (TE16L)
Q1505	8-729-043-53	s TRANSISTOR IRFU110
Q1506	8-729-120-28	s TRANSISTOR 2SC1623-L5L6
Q1507	8-729-120-28	s TRANSISTOR 2SC1623-L5L6
Q1508	8-729-019-85	s TRANSISTOR 2SC3392-5-TB
Q1509	8-729-824-24	s TRANSISTOR 2SA1338-5-TB
Q1510	8-729-019-85	s TRANSISTOR 2SC3392-5-TB
Q1511	8-729-824-24	s TRANSISTOR 2SA1338-5-TB
Q1512	8-729-041-37	s TRANSISTOR 2SJ377 (TE16L)
Q1513	8-729-041-37	s TRANSISTOR 2SJ377 (TE16L)
Q1514	8-729-120-28	s TRANSISTOR 2SC1623-L5L6
Q1515	8-729-026-49	s TRANSISTOR 2SA1037AK-T146-R
Q1516	8-729-120-28	s TRANSISTOR 2SC1623-L5L6

(D BOARD)

Ref. No. or Q'ty	Part No.	SP Description
Q1517	8-729-120-28	s TRANSISTOR 2SC1623-L5L6
Q1518	8-729-026-49	s TRANSISTOR 2SA1037AK-T146-R
Q1519	8-729-120-28	s TRANSISTOR 2SC1623-L5L6
Q1520	8-729-422-33	s TRANSISTOR 2SD601A-Q-TX
Q1521	8-729-140-96	s TRANSISTOR 2SD774-34
Q1522	1-801-806-11	s TRANSISTOR DTC144EKA
Q1523	1-801-806-11	s TRANSISTOR DTC144EKA
Q1524	8-729-120-28	s TRANSISTOR 2SC1623-L5L6
Q1525	8-729-120-28	s TRANSISTOR 2SC1623-L5L6
Q1526	1-801-806-11	s TRANSISTOR DTC144EKA
Q1527	1-801-806-11	s TRANSISTOR DTC144EKA
Q1528	8-729-043-48	s TRANSISTOR IRFI630G-LF
Q1529	8-729-043-48	s TRANSISTOR IRFI630G-LF
Q1530	8-729-120-28	s TRANSISTOR 2SC1623-L5L6
R501	1-218-871-11	s RESISTOR,CHIP 10K 1/10W (1608)
R502	1-218-865-11	s RESISTOR,CHIP 5.6K 1/10W(1608)
R503	1-216-821-11	s RESISTOR,CHIP 1.0K 1/10W(1608)
R504	1-216-837-11	s RESISTOR,CHIP 22K 1/16W 1608
R505	1-260-093-11	s RESISTOR,CARBON 330 1/2W
R506	1-216-809-11	s RESISTOR,CHIP 100 1/10W 1608
R507	1-216-801-11	s RESISTOR,CHIP 22 1/10W (1608)
R508	1-216-801-11	s RESISTOR,CHIP 22 1/10W (1608)
R509	1-216-809-11	s RESISTOR,CHIP 100 1/10W 1608
R510	1-216-829-11	s RESISTOR,CHIP 4.7K 1/10W(1608)
R511	1-218-854-11	s RESISTOR,CHIP 2K 1/10W (1608)
R512	1-218-858-11	s RESISTOR,CHIP 3K 1/10W (1608)
R513	1-218-849-11	s RESISTOR,CHIP 1.2K 1/10W(1608)
R514	1-216-821-11	s RESISTOR,CHIP 1.0K 1/10W(1608)
R515	1-216-809-11	s RESISTOR,CHIP 100 1/10W 1608
R516	1-216-797-11	s RESISTOR,CHIP 10 1/10W 1608
R517	1-216-821-11	s RESISTOR,CHIP 1.0K 1/10W(1608)
R518	1-216-827-11	s RESISTOR,CHIP 3.3K 1/10W 1608
R519	1-216-825-11	s RESISTOR,CHIP 2.2K 1/10W 1608
R520	1-216-825-11	s RESISTOR,CHIP 2.2K 1/10W 1608
R521	1-249-409-11	s RESISTOR,CARBON 220 1/4W SMALL
R522	1-216-830-11	s RESISTOR,CHIP 5.6K 1/10W 1608
R523	1-216-833-11	s RESISTOR,CHIP 10K 1/10W (1608)
R524	1-216-833-11	s RESISTOR,CHIP 10K 1/10W (1608)
R525	1-216-837-11	s RESISTOR,CHIP 22K 1/16W 1608
R526	1-216-833-11	s RESISTOR,CHIP 10K 1/10W (1608)
R527	1-218-885-11	s RESISTOR,CHIP 39K 1/10W (1608)
R528	1-218-873-11	s RESISTOR,CHIP 12K 1/10W (1608)
R529	1-218-887-11	s RESISTOR,CHIP 47K 1/10W (1608)
R530	1-218-858-11	s RESISTOR,CHIP 3K 1/10W (1608)
R531	1-218-851-11	s RESISTOR,CHIP 1.5K 1/10W(1608)
R532	1-218-899-11	s RESISTOR,CHIP 150K 1/10W(1608)
R533	1-216-837-11	s RESISTOR,CHIP 22K 1/16W 1608
R534	1-216-825-11	s RESISTOR,CHIP 2.2K 1/10W 1608
R535	1-216-809-11	s RESISTOR,CHIP 100 1/10W 1608
R536	1-218-880-11	s RESISTOR,CHIP 24K 1/10W (1608)
R537	1-218-847-11	s RESISTOR,CHIP 1K 1/10W (1608)
R538	1-218-863-11	s RESISTOR,CHIP 4.7K 1/10W(1608)
R539	1-218-863-11	s RESISTOR,CHIP 4.7K 1/10W(1608)
R540	1-218-879-11	s RESISTOR,CHIP 22K 1/10W (1608)
R541	1-218-887-11	s RESISTOR,CHIP 47K 1/10W (1608)
R542	1-218-855-11	s RESISTOR,CHIP 2.2K 1/10W(1608)
R543	1-216-846-11	s RESISTOR,CHIP 120K 1/16W (1608)
R544	1-216-817-11	s RESISTOR,CHIP 470 1/10W 1608
R545	1-216-837-11	s RESISTOR,CHIP 22K 1/16W 1608

(D BOARD)

Ref. No. or Q'ty	Part No.	SP Description
R546	1-216-829-11	s RESISTOR,CHIP 4.7K 1/10W(1608)
R547	1-216-833-11	s RESISTOR,CHIP 10K 1/10W (1608)
R548	1-216-843-11	s RESISTOR,CHIP 68K 1/10W (1608)
R549	1-218-881-11	s RESISTOR, CHIP 27K 1/10W(1608)
R550	1-216-834-11	s RESISTOR,CHIP 12K 1/16W 1608
R551	1-216-804-11	s RESISTOR,CHIP 39 1/16W 1608
R552	1-216-797-11	s RESISTOR,CHIP 10 1/10W 1608
R553	1-216-802-11	s RESISTOR,CHIP 27 1/16W 1608
R554	1-216-841-11	s RESISTOR, CHIP 47K 1/10W 1608
R555	1-218-863-11	s RESISTOR,CHIP 4.7K 1/10W(1608)
R556	1-216-833-11	s RESISTOR,CHIP 10K 1/10W (1608)
R557	1-218-863-11	s RESISTOR,CHIP 4.7K 1/10W(1608)
R558	1-216-837-11	s RESISTOR,CHIP 22K 1/16W 1608
R559	1-218-863-11	s RESISTOR,CHIP 4.7K 1/10W(1608)
R560	1-218-885-11	s RESISTOR,CHIP 39K 1/10W (1608)
R561	1-218-851-11	s RESISTOR,CHIP 1.5K 1/10W(1608)
R562	1-216-824-11	s RESISTOR, CHIP 1.8K 1/10W 1608
R563	1-216-848-11	s RESISTOR,CHIP 180K 1/16 (1608)
R564	1-216-809-11	s RESISTOR,CHIP 100 1/10W 1608
R565	1-216-365-00	s RESISTOR,METAL FILM 0.47/2W
R566	1-216-837-11	s RESISTOR,CHIP 22K 1/16W 1608
R567	1-216-840-11	s RESISTOR,CHIP 39K 1/10W 1608
R568	1-216-821-11	s RESISTOR,CHIP 1.0K 1/10W(1608)
R569	1-216-833-11	s RESISTOR,CHIP 10K 1/10W (1608)
R570	1-216-833-11	s RESISTOR,CHIP 10K 1/10W (1608)
R571	1-216-821-11	s RESISTOR,CHIP 1.0K 1/10W(1608)
R572	1-216-853-11	s RESISTOR,CHIP 470K 1/16W(1608)
R573	1-249-421-11	s RESISTOR,CARBON 2.2K 1/4W
R574	1-216-823-11	s RESISTOR, CHIP 1.5K 1/10W
R575	1-216-830-11	s RESISTOR,CHIP 5.6K 1/10W 1608
R576	1-216-357-00	s RESISTOR,METAL FILM 4.7/1W
R577	1-216-821-11	s RESISTOR,CHIP 1.0K 1/10W(1608)
R578	1-216-834-11	s RESISTOR,CHIP 12K 1/16W 1608
R579	1-249-390-11	s RES,CARBON 5.6 1/4W
R580	1-216-829-11	s RESISTOR,CHIP 4.7K 1/10W(1608)
R581	1-249-383-11	s RES,CARBON 1.5 1/4W
R582	1-216-818-11	s RESISTOR, CHIP 560 1/10W 1608
R583	1-216-832-11	s RESISTOR,CHIP 8.2K 1/16W 1608
R584	1-216-829-11	s RESISTOR,CHIP 4.7K 1/10W(1608)
R585	1-216-815-11	s RESISTOR,CHIP 330 1/10W 1608
R586	1-216-830-11	s RESISTOR,CHIP 5.6K 1/10W 1608
R587	1-216-837-11	s RESISTOR,CHIP 22K 1/16W 1608
R588	1-216-431-11	s RESISTOR,METAL FILM 560/1W
R589	1-216-824-11	s RESISTOR, CHIP 1.8K 1/10W 1608
R590	1-216-436-00	s RESISTOR,METAL FILM 3.9K/1W
R591	1-216-830-11	s RESISTOR,CHIP 5.6K 1/10W 1608
R592	1-216-822-11	s RESISTOR, CHIP 1.2K 1/10W 1608
R593	1-216-825-11	s RESISTOR,CHIP 2.2K 1/10W 1608
R594	1-216-816-11	s RESISTOR, CHIP 390 1/10W 1608
R595	1-218-867-11	s RESISTOR,CHIP 6.8K 1/10W(1608)
R596	1-216-797-11	s RESISTOR,CHIP 10 1/10W 1608
R597	1-216-797-11	s RESISTOR,CHIP 10 1/10W 1608
R598	1-216-430-11	s RESISTOR,METAL FILM 390/1W
R599	1-216-833-11	s RESISTOR,CHIP 10K 1/10W (1608)
R1500	1-216-830-11	s RESISTOR,CHIP 5.6K 1/10W 1608
R1501	1-216-829-11	s RESISTOR,CHIP 4.7K 1/10W(1608)
R1502	1-216-829-11	s RESISTOR,CHIP 4.7K 1/10W(1608)
R1503	1-202-933-61	s RESISTOR, FUSE 0.1 1/2W
R1504	1-216-829-11	s RESISTOR,CHIP 4.7K 1/10W(1608)

(D BOARD)

Ref. No. or Q'ty	Part No.	SP Description
R1505	1-216-801-11	s RESISTOR,CHIP 22 1/10W (1608)
R1506	1-216-801-11	s RESISTOR,CHIP 22 1/10W (1608)
R1507	1-216-829-11	s RESISTOR,CHIP 4.7K 1/10W(1608)
R1508	1-218-875-11	s RESISTOR,CHIP 15K 1/10W (1608)
R1509	1-216-829-11	s RESISTOR,CHIP 4.7K 1/10W(1608)
R1510	1-216-829-11	s RESISTOR,CHIP 4.7K 1/10W(1608)
R1511	1-218-861-11	s RESISTOR,CHIP 3.9K 1/10W(1608)
R1512	1-218-863-11	s RESISTOR,CHIP 4.7K 1/10W(1608)
R1513	1-216-833-11	s RESISTOR,CHIP 10K 1/10W (1608)
R1514	1-216-846-11	s RESISTOR,CHIP 120K 1/16W (1608)
R1515	1-218-881-11	s RESISTOR, CHIP 27K 1/10W(1608)
R1516	1-216-843-11	s RESISTOR,CHIP 68K 1/10W (1608)
R1517	1-216-829-11	s RESISTOR,CHIP 4.7K 1/10W(1608)
R1518	1-216-829-11	s RESISTOR,CHIP 4.7K 1/10W(1608)
R1519	1-216-833-11	s RESISTOR,CHIP 10K 1/10W (1608)
R1520	1-218-880-11	s RESISTOR,CHIP 24K 1/10W (1608)
R1521	1-216-837-11	s RESISTOR,CHIP 22K 1/16W 1608
R1522	1-216-829-11	s RESISTOR,CHIP 4.7K 1/10W(1608)
R1523	1-216-827-11	s RESISTOR, CHIP 3.3K 1/10W 1608
R1524	1-216-829-11	s RESISTOR,CHIP 4.7K 1/10W(1608)
R1525	1-216-829-11	s RESISTOR,CHIP 4.7K 1/10W(1608)
R1526	1-216-829-11	s RESISTOR,CHIP 4.7K 1/10W(1608)
R1527	1-216-829-11	s RESISTOR,CHIP 4.7K 1/10W(1608)
R1528	1-202-933-61	s RESISTOR, FUSE 0.1 1/2W
R1529	1-249-377-11	s RES,CARBON 0.47 1/4W
R1530	1-216-829-11	s RESISTOR,CHIP 4.7K 1/10W(1608)
R1531	1-216-801-11	s RESISTOR,CHIP 22 1/10W (1608)
R1532	1-216-829-11	s RESISTOR,CHIP 4.7K 1/10W(1608)
R1533	1-216-801-11	s RESISTOR,CHIP 22 1/10W (1608)
R1534	1-216-834-11	s RESISTOR,CHIP 12K 1/16W 1608
R1535	1-216-822-11	s RESISTOR, CHIP 1.2K 1/10W 1608
R1536	1-216-829-11	s RESISTOR,CHIP 4.7K 1/10W(1608)
R1537	1-216-829-11	s RESISTOR,CHIP 4.7K 1/10W(1608)
R1538	1-216-833-11	s RESISTOR,CHIP 10K 1/10W (1608)
R1539	1-216-833-11	s RESISTOR,CHIP 10K 1/10W (1608)
R1540	1-216-829-11	s RESISTOR,CHIP 4.7K 1/10W(1608)
R1541	1-216-837-11	s RESISTOR,CHIP 22K 1/16W 1608
R1542	1-216-833-11	s RESISTOR,CHIP 10K 1/10W (1608)
R1543	1-216-833-11	s RESISTOR,CHIP 10K 1/10W (1608)
R1544	1-216-829-11	s RESISTOR,CHIP 4.7K 1/10W(1608)
R1545	1-216-829-11	s RESISTOR,CHIP 4.7K 1/10W(1608)
R1546	1-218-866-11	s RESISTOR,CHIP 6.2K 1/10W(1608)
R1547	1-218-867-11	s RESISTOR,CHIP 6.8K 1/10W(1608)
R1548	1-216-825-11	s RESISTOR,CHIP 2.2K 1/10W 1608
R1549	1-216-829-11	s RESISTOR,CHIP 4.7K 1/10W(1608)
R1550	1-216-830-11	s RESISTOR,CHIP 5.6K 1/10W 1608
R1551	1-218-862-11	s RESISTOR,CHIP 4.3K 1/10W(1608)
R1552	1-216-833-11	s RESISTOR,CHIP 10K 1/10W (1608)
R1553	1-216-833-11	s RESISTOR,CHIP 10K 1/10W (1608)
R1554	1-216-833-11	s RESISTOR,CHIP 10K 1/10W (1608)
R1555	1-216-832-11	s RESISTOR,CHIP 8.2K 1/16W 1608
R1556	1-216-833-11	s RESISTOR,CHIP 10K 1/10W (1608)
R1557	1-216-829-11	s RESISTOR,CHIP 4.7K 1/10W(1608)
R1558	1-216-833-11	s RESISTOR,CHIP 10K 1/10W (1608)
R1559	1-216-837-11	s RESISTOR,CHIP 22K 1/16W 1608
R1560	1-216-830-11	s RESISTOR,CHIP 5.6K 1/10W 1608
R1561	1-216-833-11	s RESISTOR,CHIP 10K 1/10W (1608)
R1562	1-216-829-11	s RESISTOR,CHIP 4.7K 1/10W(1608)
R1563	1-216-821-11	s RESISTOR,CHIP 1.0K 1/10W(1608)

(D BOARD)

Ref. No. or Q'ty	Part No.	SP Description
R1564	1-249-393-11	s RES,CARBON 10 1/4W
R1565	1-216-833-11	s RESISTOR,CHIP 10K 1/10W (1608)
R1566	1-218-882-11	s RESISTOR, CHIP 30K 1/10W(1608)
R1567	1-216-827-11	s RESISTOR, CHIP 3.3K 1/10W 1608
R1568	1-218-843-11	s RESISTOR,CHIP 680 1/10W (1608)
R1569	1-218-877-11	s RESISTOR,CHIP 18K 1/10W (1608)
R1570	1-260-300-11	s RESISTOR CARBON 4.7 1/2W(SMALL)
R1571	1-211-775-11	s RESISTOR FUSE 10 1/4W
R1572	1-260-095-11	s RESISTOR,CARBON 470 1/2W
R1573	1-216-835-11	s RESISTOR,CHIP 15K 1/10W
R1574	1-216-835-11	s RESISTOR,CHIP 15K 1/10W
R1575	1-216-833-11	s RESISTOR,CHIP 10K 1/10W (1608)
R1576	1-216-833-11	s RESISTOR,CHIP 10K 1/10W (1608)
R1577	1-216-833-11	s RESISTOR,CHIP 10K 1/10W (1608)
R1578	1-216-833-11	s RESISTOR,CHIP 10K 1/10W (1608)
R1579	1-218-734-11	s RESISTOR,CHIP 56K 1/16W(1608)
R1580	1-218-857-11	s RESISTOR,CHIP 2.7K 1/10W(1608)
R1581	1-218-842-11	s RESISTOR,CHIP 620 1/10W (1608)
R1582	△ 1-218-854-11	s RESISTOR,CHIP 2K 1/10W (1608)
R1583	1-218-839-11	s RESISTOR,CHIP 470 1/10W (1608)
R1584	1-218-704-11	s RESISTOR,CHIP 3.3K 1/16W(1608)
R1585	1-216-821-11	s RESISTOR,CHIP 1.0K 1/10W(1608)
R1586	1-218-726-11	s RESISTOR CHIP 27K 1/16W (1608)
R1587	1-218-728-11	s RESISTOR,CHIP 33K 1/16W
R1588	1-218-732-11	s RESISTOR,CHIP 47K 1/16W(1608)
R1589	1-218-718-11	s RESISTOR CHIP 12K 1/16W (1608)
R1590	1-218-704-11	s RESISTOR,CHIP 3.3K 1/16W(1608)
R1591	1-218-704-11	s RESISTOR,CHIP 3.3K 1/16W(1608)
R1592	1-218-704-11	s RESISTOR,CHIP 3.3K 1/16W(1608)
R1593	△ 1-218-708-11	s RESISTOR,CHIP 4.7K 1/16W(1608)
R1594	△ 1-218-716-11	s RESISTOR,CHIP 10K 1/16W(1608)
R1595	1-218-714-11	s RESISTOR,CHIP 8.2K 1/16W(1608)
R1596	1-218-704-11	s RESISTOR,CHIP 3.3K 1/16W(1608)
R1597	1-218-704-11	s RESISTOR,CHIP 3.3K 1/16W(1608)
R1598	1-216-436-00	s RESISTOR,METAL FILM 3.9K/1W
R1599	1-249-435-11	s RESISTOR CARBON 33K 1/4W
R1600	1-216-845-11	s RESISTOR,CHIP 100K 1/10W(1608)
R1601	1-216-841-11	s RESISTOR, CHIP 47K 1/10W 1608
R1602	1-216-845-11	s RESISTOR,CHIP 100K 1/10W(1608)
R1603	1-216-837-11	s RESISTOR,CHIP 22K 1/16W 1608
R1604	1-216-833-11	s RESISTOR,CHIP 10K 1/10W (1608)
R1605	1-216-833-11	s RESISTOR,CHIP 10K 1/10W (1608)
R1606	1-216-833-11	s RESISTOR,CHIP 10K 1/10W (1608)
R1607	1-216-825-11	s RESISTOR,CHIP 2.2K 1/10W 1608
R1608	1-216-833-11	s RESISTOR,CHIP 10K 1/10W (1608)
R1609	1-216-833-11	s RESISTOR,CHIP 10K 1/10W (1608)
R1610	1-216-818-11	s RESISTOR, CHIP 560 1/10W 1608
R1611	1-216-818-11	s RESISTOR, CHIP 560 1/10W 1608
R1612	1-218-765-11	s RESISTOR,CHIP 360K1/10W(2012)
R1613	1-216-797-11	s RESISTOR,CHIP 10 1/10W 1608
R1614	1-218-765-11	s RESISTOR,CHIP 360K1/10W(2012)
R1615	1-216-797-11	s RESISTOR,CHIP 10 1/10W 1608
R1616	1-216-833-11	s RESISTOR,CHIP 10K 1/10W (1608)
R1617	1-216-833-11	s RESISTOR,CHIP 10K 1/10W (1608)
R1618	1-215-879-11	s RESISTOR,METAL FILM 47K/1W
R1619	1-249-381-11	s RES,CARBON 1 (1/4W)
R1620	1-216-833-11	s RESISTOR,CHIP 10K 1/10W (1608)
R1621	1-216-833-11	s RESISTOR,CHIP 10K 1/10W (1608)
R1622	1-249-414-11	s RESISTOR,CARBON 560 1/4W SMALL

(D BOARD)

Ref. No. or Q'ty	Part No.	SP Description
R1623	1-216-821-11	s RESISTOR,CHIP 1.0K 1/10W(1608)
R1624	1-216-813-11	s RESISTOR, CHIP 220 1/10W 1608
R1625	1-216-833-11	s RESISTOR,CHIP 10K 1/10W (1608)
R2500	1-216-809-11	s RESISTOR,CHIP 100 1/10W 1608
R2501	1-216-826-11	s RESISTOR,CHIP 2.7K 1/10W(1608)
R2502	1-216-826-11	s RESISTOR,CHIP 2.7K 1/10W(1608)
RV1501	1-241-763-11	s RESISTOR ADJ 4.7K (CERMET)
RY1501	1-755-444-11	s RELAY, POWER
X501	1-767-933-11	s OSCILLATOR, CERAMIC (500kHz)

G BOARD

Ref. No. or Q'ty	Part No.	SP Description
1pc	A-1300-856-A	s MOUNTED CIRCUIT BOARD, G
3pcs	4-382-854-01	s SCREW +PSW M3X8 (EP-FE/ZN/CM2)
1pc	4-382-854-11	s SCREW, +PSW M3X10 (EP-FE/ZNBK/CM)
C601	Δ 1-113-900-11	s CAPACITOR, CERAMIC 470PF/250V
C602	Δ 1-104-708-11	s CAP, FILM 0.47MF/250VAC
C603	Δ 1-104-706-11	s CAPACITOR, FILM 0.22MF/250VAC
C604	Δ 1-113-926-11	s CAPACITOR, CERAMIC 4700PF/250V
C605	Δ 1-113-900-11	s CAPACITOR, CERAMIC 470PF/250V
C606	Δ 1-113-926-11	s CAPACITOR, CERAMIC 4700PF/250V
C607	1-162-970-11	s CAPACITOR CERAMIC 0.01MF/25V B
C611	1-107-907-11	s CAPACITOR, ELECT 22MF/50V
C613	1-107-905-11	s CAPACITOR, ELECT 4.7MF/50V
C614	1-107-910-11	s CAPACITOR, ELECT 100MF/50V
C615	1-131-913-11	s CAP, ALUMINIUM ELECT
C616	1-130-495-00	s CAPACITOR FILM 0.1MF/50V PETP
C618	1-131-876-11	s CAP, PPS FILM
C620	1-107-910-11	s CAPACITOR, ELECT 100MF/50V
C621	1-107-906-11	s CAPACITOR, ELECT 10MF/50V(105)
C622	1-107-909-11	s CAPACITOR, ELECT 47MF/50V
C623	1-127-825-11	s CAP, FILM 0.0033MF/1.0KV
C629	1-162-927-11	s CAPACITOR, CERAMIC 100PF/50V CH
C630	1-137-479-11	s CAPACITOR FILM 1MF/400V
C631	1-125-891-11	s CAPACITOR CERAMIC 0.47MF/10V
C632	1-107-910-11	s CAPACITOR, ELECT 100MF/50V
C637	1-107-910-11	s CAPACITOR, ELECT 100MF/50V
C644	1-127-825-11	s CAP, FILM 0.0033MF/1.0KV
C651	1-162-970-11	s CAPACITOR CERAMIC 0.01MF/25V B
C690	1-111-074-11	s CAPACITOR, ELECT 3900MF/25V
C691	1-111-074-11	s CAPACITOR, ELECT 3900MF/25V
C693	1-126-942-61	s CAPACITOR, ELECT 1000MF/25V
CN601	1-691-960-11	o PIN, CONNECTOR (PC BOARD) 3P
CN602	1-580-843-11	o PIN, CONNECTOR (POWER)
CN690	1-764-101-11	s PIN, CONNECTOR (PC BOARD) 2P
D601	Δ 8-719-510-53	s DIODE D4SB60L
D602	8-719-304-63	s DIODE RM11C (RECTI)
D603	8-719-037-53	s DIODE RD27SB-T1
D604	8-719-989-76	s DIODE SC802-04-TE12RA
D605	8-719-989-21	s DIODE SC311-6-TE12RA
D606	8-719-989-21	s DIODE SC311-6-TE12RA
D607	8-719-989-21	s DIODE SC311-6-TE12RA
D608	8-719-063-73	s DIODE D1NL20U-TR
D620	8-719-063-73	s DIODE D1NL20U-TR
D661	8-719-158-53	s DIODE RD13SB2
D662	8-719-063-73	s DIODE D1NL20U-TR
D663	8-719-063-73	s DIODE D1NL20U-TR
D668	8-719-063-73	s DIODE D1NL20U-TR
D669	8-719-037-53	s DIODE RD27SB-T1
D690	8-719-988-30	s DIODE D30SC4M
F601	Δ 1-576-624-11	s FUSE (3.15A/250V)
FH601	1-533-223-11	s CLIP, FUSE
FH602	1-533-223-11	s CLIP, FUSE
IC603	8-749-013-78	s IC MCR5102
IC666	8-749-018-08	s IC MZ1532
IC690	8-749-920-44	s IC SE012N (HYBRID)
L601	1-406-978-11	s COIL, CHOKE 150UH
L690	1-469-563-11	s INDUCTOR, MICRO

(G BOARD)

Ref. No. or Q'ty	Part No.	SP Description
PH601	8-749-016-81	s PHOTO COUPLER PC123Y22
R601	Δ 1-220-825-11	s RES, (SURGE RESISTANT) 330K
R602	1-215-929-11	s RESISTOR, METAL FILM 100K/3W
R603	1-215-929-11	s RESISTOR, METAL FILM 100K/3W
R604	1-218-850-11	s RESISTOR, CHIP 1.3K 1/10W(1608)
R605	1-202-933-61	s RESISTOR, FUSE 0.1 1/2W
R606	1-215-904-11	s RESISTOR, METAL FILM 100K/2W
R607	1-215-904-11	s RESISTOR, METAL FILM 100K/2W
R608	1-216-346-00	s RESISTOR, METAL FILM 0.56/1W
R610	1-218-871-11	s RESISTOR, CHIP 10K 1/10W (1608)
R615	1-216-817-11	s RESISTOR, CHIP 470 1/10W 1608
R621	Δ 1-219-513-11	s RESISTOR 4.7M 1/2W (SURGE)
R622	Δ 1-219-513-11	s RESISTOR 4.7M 1/2W (SURGE)
R644	1-215-485-00	s RESISTOR METAL FILM 470K 1/4W
R645	1-215-481-00	s RESISTOR METAL FILM 330K 1/4W
R653	1-215-485-00	s RESISTOR METAL FILM 470K 1/4W
R657	1-218-873-11	s RESISTOR, CHIP 12K 1/10W (1608)
R658	1-218-847-11	s RESISTOR, CHIP 1K 1/10W (1608)
R668	Δ 1-242-803-11	s RES, CEMENT-COATED 1.5 7W
R669	Δ 1-242-803-11	s RES, CEMENT-COATED 1.5 7W
R670	1-207-615-00	s RESISTOR WIREWOUND 0.33/3W
R671	1-207-615-00	s RESISTOR WIREWOUND 0.33/3W
R674	1-249-377-11	s RES, CARBON 0.47 1/4W
R675	1-216-837-11	s RESISTOR, CHIP 22K 1/16W 1608
R677	1-216-346-00	s RESISTOR, METAL FILM 0.56/1W
R678	1-260-364-11	s RESISTOR, CARBON 1M 1/2W
R679	1-260-364-11	s RESISTOR, CARBON 1M 1/2W
R680	1-260-364-11	s RESISTOR, CARBON 1M 1/2W
R681	1-260-364-11	s RESISTOR, CARBON 1M 1/2W
R690	1-249-410-11	s RES, CARBON 270 1/4W (SMALL)
R691	1-216-825-11	s RESISTOR, CHIP 2.2K 1/10W 1608
R692	1-216-821-11	s RESISTOR, CHIP 1.0K 1/10W(1608)
R693	1-249-401-11	s RES, CARBON 47 1/4W (SMALL)
T601	Δ 1-419-622-11	s COIL, LINE FILTER
T602	1-435-154-11	s TRANSFORMER, FERRITE
T604	1-435-153-11	s TRANSFORMER, CONVERTER
VDR602	Δ 1-801-073-31	s VARISTOR ERZV14D471

H BOARD

Ref. No. or Q'ty	Part No.	SP Description
1pc	A-1401-777-A	s MOUNTED CIRCUIT BOARD, H
CN51	1-564-528-11	s PLUG, CONNECTOR (13P) (L-TYPE)
CN52	1-564-524-11	o PLUG, CONNECTOR (9P) (L-TYPE)
D51	8-719-301-42	s DIODE SEL2410E
R51	1-216-053-00	s RESISTOR CHIP 1.5K 1/10W(2012)
R52	1-216-075-00	s RESISTOR CHIP 12K 1/10W(2012)
R53	1-216-043-91	s RESISTOR, CHIP 560 1/10W(2125)
R54	1-216-043-91	s RESISTOR, CHIP 560 1/10W(2125)
R55	1-216-043-91	s RESISTOR, CHIP 560 1/10W(2125)
R56	1-216-043-91	s RESISTOR, CHIP 560 1/10W(2125)
R57	1-216-043-91	s RESISTOR, CHIP 560 1/10W(2125)
R58	1-216-043-91	s RESISTOR, CHIP 560 1/10W(2125)
R59	1-216-043-91	s RESISTOR, CHIP 560 1/10W(2125)
R61	1-216-043-91	s RESISTOR, CHIP 560 1/10W(2125)
R62	1-216-043-91	s RESISTOR, CHIP 560 1/10W(2125)
R63	1-216-059-00	s RESISTOR, CHIP 2.7K 1/10W(2012)
R64	1-216-047-91	s RESISTOR, CHIP 820 1/10W(2125)
R65	1-216-039-00	s RESISTOR, CHIP 390 1/10W(2012)
R66	1-216-035-00	s RESISTOR, CHIP 270 1/10W(2012)
R67	1-216-059-00	s RESISTOR, CHIP 2.7K 1/10W(2012)
R68	1-216-051-00	s RESISTOR, CHIP 1.2K 1/10W(2012)
R70	1-216-035-00	s RESISTOR, CHIP 270 1/10W(2012)
R71	1-216-047-91	s RESISTOR, CHIP 820 1/10W(2125)
R72	1-216-039-00	s RESISTOR, CHIP 390 1/10W(2012)
R73	1-216-035-00	s RESISTOR, CHIP 270 1/10W(2012)
RV51	1-225-391-11	s RESISTOR, VAR, CARBON 20K
RV52	1-225-391-11	s RESISTOR, VAR, CARBON 20K
RV53	1-225-391-11	s RESISTOR, VAR, CARBON 20K
RV54	1-225-391-11	s RESISTOR, VAR, CARBON 20K
RV55	1-225-391-11	s RESISTOR, VAR, CARBON 20K
S51	1-570-101-41	s SWITCH, KEY BOARD (LED) (EXT SYNC)
S52	1-570-101-41	s SWITCH, KEY BOARD (LED) (16:9)
S53	1-570-101-41	s SWITCH, KEY BOARD (LED) (U/S)
S54	1-570-101-41	s SWITCH, KEY BOARD (LED) (E/O)
S55	1-570-101-41	s SWITCH, KEY BOARD (LED) (DEGAUSS)
S56	1-570-101-41	s SWITCH, KEY BOARD (LED) (OPTION B)
S57	1-570-101-41	s SWITCH, KEY BOARD (LED) (OPTION A)
S59	1-570-101-41	s SWITCH, KEY BOARD (LED) (LINE B)
S60	1-570-101-41	s SWITCH, KEY BOARD (LED) (LINE A)
S61	1-570-969-11	s SWITCH, KEY BOARD (MENU)
S62	1-570-969-11	s SWITCH, KEY BOARD (UP)
S63	1-570-969-11	s SWITCH, KEY BOARD (DOWN)
S64	1-570-969-11	s SWITCH, KEY BOARD (ENTER)

J BOARD

Ref. No. or Q'ty	Part No.	SP Description
1pc	A-1401-778-A	s MOUNTED CIRCUIT BOARD, J
CN603	1-580-843-11	o PIN, CONNECTOR (POWER)
CN604	1-564-506-11	o PLUG, CONNECTOR (3P)
S601	Δ 1-571-433-21	s SWITCH, PUSH (AC POWER)

P BOARD

Ref. No. or Q'ty	Part No.	SP Description
1pc	A-1300-857-A	s MOUNTED CIRCUIT BOARD, P
C801	1-162-116-00	s CAPACITOR, CERAMIC 680PF/2KVDC
C802	1-162-116-00	s CAPACITOR, CERAMIC 680PF/2KVDC
C803	1-102-228-00	s CAPACITOR, CERAMIC; 470PF/500V
C804	1-162-970-11	s CAPACITOR CERAMIC 0.01MF/25V B
C806	1-126-941-11	s CAPACITOR, ELECT 470MF/25V
C807	1-102-228-00	s CAPACITOR, CERAMIC; 470PF/500V
C808	1-123-024-21	s CAPACITOR, ELECT 33MF/160V(85C)
C809	1-126-971-11	s CAPACITOR ELECT 470MF/50V
C810	1-106-375-12	s CAPACITOR FILM 0.022MF/200V
C812	1-162-318-11	s CAPACITOR, CERAMIC 1000PF/500V
C813	1-102-228-00	s CAPACITOR, CERAMIC; 470PF/500V
C814	1-137-150-11	s CAPACITOR, FILM 0.01MF/100V(PP)
C815	1-102-228-00	s CAPACITOR, CERAMIC; 470PF/500V
C816	1-162-116-00	s CAPACITOR, CERAMIC 680PF/2KVDC
C817	Δ 1-137-544-11	s CAPACITOR FILM 10000PF/600V
C818	1-107-646-11	s CAPACITOR, ELECT 33MF/200V
C819	Δ 1-137-545-11	s CAPACITOR FILM 13000PF/600V
C820	Δ 1-107-385-11	s CAPACITOR, FILM 0.056/200V PETP
C821	1-137-353-11	s CAPACITOR FILM 0.047MF/100V PP
CN801	1-564-596-11	o PLUG, CONNECTOR (15P)
CN802	1-508-766-00	o 4P PLUG
CN803	1-564-508-11	o PLUG, CONNECTOR (5P)
D802	8-719-302-43	s DIODE EL1Z (RECTI)
D803	8-719-302-43	s DIODE EL1Z (RECTI)
D804	8-719-979-85	s DIODE EGP20G
D805	8-719-302-43	s DIODE EL1Z (RECTI)
D806	8-719-302-43	s DIODE EL1Z (RECTI)
D807	8-719-302-43	s DIODE EL1Z (RECTI)
D808	8-719-908-03	s DIODE GP08D
D809	8-719-908-03	s DIODE GP08D
L801	1-412-529-11	s INDUCTOR, MICRO 22UH
L802	Δ 1-460-225-11	s COIL, HORIZONTAL LINEARITY
L803	1-406-987-21	s COIL, CHOKE 4.7MMH
L805	1-459-442-00	s COIL (WITH CORE)
L806	1-422-613-11	s COIL, AIR-CORE
NL801	1-519-108-99	s NEON LAMP ASSY
Q802	8-729-195-82	s TRANSISTOR 2SC2958
Q803	8-729-048-07	s TRANSISTOR 2SD2578-CA
R801	1-249-414-11	s RESISTOR, CARBON 560 1/4W SMALL
R804	1-216-833-11	s RESISTOR, CHIP 10K 1/10W (1608)
R805	1-249-377-11	s RES, CARBON 0.47 1/4W
R806	1-215-859-00	s RESISTOR, METAL 22/1W
R807	1-249-419-11	s RESISTOR, CARBON 1.5K 1/4W
R808	1-216-425-11	s RESISTOR, METAL FILM 56/1W
R809	1-249-383-11	s RES, CARBON 1.5 1/4W
R810	1-216-809-11	s RESISTOR, CHIP 100 1/10W 1608
R811	1-249-377-11	s RES, CARBON 0.47 1/4W
RV801	1-223-102-00	s RESISTOR, ADJUST, WIREWOUND 120
T801	1-426-668-11	s TRANSFORMER, FERRITE (HDT)
T802	Δ 1-439-526-13	s TRANSFORMER ASSY, FLYBACK

Q BOARD

Ref. No. or Q'ty	Part No.	SP Description
1pc	A-1302-028-A	s MOUNTED CIRCUIT BOARD, Q
1pc	1-694-968-11	s TERMINALBOARDASSY INPUT/OUTPUT
2pcs	7-685-135-19	s SCREW +PT2.6X10 (EP-FE/ZNBK/CM
C2700	1-126-514-11	s CAPACITOR, ELECT 22MF/16V
C2701	1-126-514-11	s CAPACITOR, ELECT 22MF/16V
C2702	1-162-995-11	s CAPACITOR, CERAMIC 0.022MF/50V
C2703	1-126-514-11	s CAPACITOR, ELECT 22MF/16V
C2710	1-126-514-11	s CAPACITOR, ELECT 22MF/16V
C2711	1-126-514-11	s CAPACITOR, ELECT 22MF/16V
C2712	1-162-995-11	s CAPACITOR, CERAMIC 0.022MF/50V
C2713	1-126-514-11	s CAPACITOR, ELECT 22MF/16V
C2719	1-126-795-11	s CAPACITOR, ELECT 10MF/50V
C2720	1-107-826-11	s CAPACITOR, CHIP CERAMIC 0.1MF
C2721	1-126-514-11	s CAPACITOR, ELECT 22MF/16V
C2722	1-162-995-11	s CAPACITOR, CERAMIC 0.022MF/50V
C2730	1-126-795-11	s CAPACITOR, ELECT 10MF/50V
C2731	1-126-514-11	s CAPACITOR, ELECT 22MF/16V
C2732	1-162-995-11	s CAPACITOR, CERAMIC 0.022MF/50V
C2733	1-126-795-11	s CAPACITOR, ELECT 10MF/50V
C2740	1-126-514-11	s CAPACITOR, ELECT 22MF/16V
C2741	1-126-514-11	s CAPACITOR, ELECT 22MF/16V
C2742	1-162-995-11	s CAPACITOR, CERAMIC 0.022MF/50V
C2743	1-126-514-11	s CAPACITOR, ELECT 22MF/16V
C2750	1-126-795-11	s CAPACITOR, ELECT 10MF/50V
C2751	1-126-514-11	s CAPACITOR, ELECT 22MF/16V
C2752	1-162-995-11	s CAPACITOR, CERAMIC 0.022MF/50V
C2753	1-126-795-11	s CAPACITOR, ELECT 10MF/50V
C2760	1-126-795-11	s CAPACITOR, ELECT 10MF/50V
C2761	1-126-514-11	s CAPACITOR, ELECT 22MF/16V
C2762	1-162-995-11	s CAPACITOR, CERAMIC 0.022MF/50V
C2763	1-126-795-11	s CAPACITOR, ELECT 10MF/50V
C2770	1-126-795-11	s CAPACITOR, ELECT 10MF/50V
C2771	1-126-514-11	s CAPACITOR, ELECT 22MF/16V
C2772	1-162-995-11	s CAPACITOR, CERAMIC 0.022MF/50V
C2773	1-126-795-11	s CAPACITOR, ELECT 10MF/50V
C2782	1-126-786-11	s CAPACITOR, ELECT 47MF/16V
C2783	1-126-786-11	s CAPACITOR, ELECT 47MF/16V
C2785	1-126-786-11	s CAPACITOR, ELECT 47MF/16V
C2787	1-126-786-11	s CAPACITOR, ELECT 47MF/16V
C2789	1-126-786-11	s CAPACITOR, ELECT 47MF/16V
C2790	1-126-795-11	s CAPACITOR, ELECT 10MF/50V
C2791	1-126-514-11	s CAPACITOR, ELECT 22MF/16V
C2792	1-162-974-11	s CAPACITOR, CERAMIC 0.01MF/50V F
C2793	1-126-786-11	s CAPACITOR, ELECT 47MF/16V
C3770	1-126-786-11	s CAPACITOR, ELECT 47MF/16V
C3771	1-165-176-11	s CAPACITOR, CERAMIC 47000PF/16V
C3772	1-162-964-11	s CAPACITOR, CERAMIC 1000PF/50V B
C3773	1-162-964-11	s CAPACITOR, CERAMIC 1000PF/50V B
C3774	1-162-964-11	s CAPACITOR, CERAMIC 1000PF/50V B
C3775	1-162-964-11	s CAPACITOR, CERAMIC 1000PF/50V B
C3776	1-162-964-11	s CAPACITOR, CERAMIC 1000PF/50V B
C3777	1-162-964-11	s CAPACITOR, CERAMIC 1000PF/50V B
C3778	1-162-964-11	s CAPACITOR, CERAMIC 1000PF/50V B
C3779	1-162-964-11	s CAPACITOR, CERAMIC 1000PF/50V B
C3780	1-164-227-11	s CAPACITOR, CERAMIC 0.022MF/25V
C3781	1-164-227-11	s CAPACITOR, CERAMIC 0.022MF/25V
C3782	1-164-227-11	s CAPACITOR, CERAMIC 0.022MF/25V
C3783	1-164-227-11	s CAPACITOR, CERAMIC 0.022MF/25V

(Q BOARD)

Ref. No. or Q'ty	Part No.	SP Description
C3784	1-164-227-11	s CAPACITOR, CERAMIC 0.022MF/25V
C3785	1-164-227-11	s CAPACITOR, CERAMIC 0.022MF/25V
C3786	1-164-227-11	s CAPACITOR, CERAMIC 0.022MF/25V
C3790	1-126-514-11	s CAPACITOR, ELECT 22MF/16V
C3791	1-126-514-11	s CAPACITOR, ELECT 22MF/16V
C3792	1-162-995-11	s CAPACITOR, CERAMIC 0.022MF/50V
CN2701	1-569-023-11	s JACK, MODULAR 8P
CN2702	1-565-167-12	s TERMINAL, (S) (WITH SW) 4P (Y/C IN)
CN2703	1-569-578-11	s TERMINAL, S (WITH SW) (Y/C OUT)
CN2705	1-564-725-11	o PIN, CONNECTOR (9P)
CN2707	1-564-724-11	o PIN, CONNECTOR (8P)
D2700	8-719-800-76	s DIODE 1SS226
D2710	8-719-800-76	s DIODE 1SS226
D2720	8-719-800-76	s DIODE 1SS226
D2730	8-719-800-76	s DIODE 1SS226
D2740	8-719-800-76	s DIODE 1SS226
D2750	8-719-800-76	s DIODE 1SS226
D2760	8-719-800-76	s DIODE 1SS226
D2770	8-719-800-76	s DIODE 1SS226
D3790	8-719-800-76	s DIODE 1SS226
D3791	8-719-073-01	s DIODE MA111-(K8) .S0
IC2782	8-759-446-66	s IC MM1113XFBE
IC2783	8-759-710-86	s IC NJM2233BM
IC2784	8-759-446-66	s IC MM1113XFBE
IC2785	8-759-710-86	s IC NJM2233BM
IC3770	8-759-484-12	s IC BU4021BF-E2
Q2700	8-729-120-28	s TRANSISTOR 2SC1623-L5L6
Q2710	8-729-120-28	s TRANSISTOR 2SC1623-L5L6
Q2720	8-729-120-28	s TRANSISTOR 2SC1623-L5L6
Q2730	8-729-026-49	s TRANSISTOR 2SA1037AK-T146-R
Q2740	8-729-120-28	s TRANSISTOR 2SC1623-L5L6
Q2750	8-729-026-49	s TRANSISTOR 2SA1037AK-T146-R
Q2760	8-729-026-49	s TRANSISTOR 2SA1037AK-T146-R
Q2770	8-729-026-49	s TRANSISTOR 2SA1037AK-T146-R
Q2780	8-729-026-49	s TRANSISTOR 2SA1037AK-T146-R
Q3790	8-729-120-28	s TRANSISTOR 2SC1623-L5L6
R2700	1-214-837-11	s RESISTOR, METAL FILM 75, 1/2W
R2701	1-216-821-11	s RESISTOR, CHIP 1.0K 1/10W (1608)
R2702	1-216-843-11	s RESISTOR, CHIP 68K 1/10W (1608)
R2703	1-216-842-11	s RESISTOR, CHIP 56K 1/16W (1608)
R2704	1-216-821-11	s RESISTOR, CHIP 1.0K 1/10W (1608)
R2705	1-216-815-11	s RESISTOR, CHIP 330 1/10W 1608
R2710	1-214-837-11	s RESISTOR, METAL FILM 75, 1/2W
R2711	1-216-821-11	s RESISTOR, CHIP 1.0K 1/10W (1608)
R2712	1-216-843-11	s RESISTOR, CHIP 68K 1/10W (1608)
R2713	1-216-842-11	s RESISTOR, CHIP 56K 1/16W (1608)
R2714	1-216-821-11	s RESISTOR, CHIP 1.0K 1/10W (1608)
R2715	1-216-815-11	s RESISTOR, CHIP 330 1/10W 1608
R2720	1-214-837-11	s RESISTOR, METAL FILM 75, 1/2W
R2721	1-216-821-11	s RESISTOR, CHIP 1.0K 1/10W (1608)
R2722	1-216-843-11	s RESISTOR, CHIP 68K 1/10W (1608)
R2723	1-216-842-11	s RESISTOR, CHIP 56K 1/16W (1608)
R2724	1-216-828-11	s RESISTOR, CHIP 3.9K 1/10W 1608
R2725	1-216-815-11	s RESISTOR, CHIP 330 1/10W 1608
R2726	1-216-821-11	s RESISTOR, CHIP 1.0K 1/10W (1608)
R2730	1-214-911-11	s RESISTOR, METAL FILM 82K/1/2W
R2731	1-216-845-11	s RESISTOR, CHIP 100K 1/10W (1608)
R2732	1-216-854-11	s RESISTOR, CHIP 560K 1/16W 1608

(Q BOARD)

Ref. No. or Q'ty	Part No.	SP Description
R2733	1-216-849-11	s RESISTOR,CHIP 220K 1/16W 1608
R2734	1-216-835-11	s RESISTOR,CHIP 15K 1/10W
R2735	1-216-809-11	s RESISTOR,CHIP 100 1/10W 1608
R2740	1-214-837-11	s RESISTOR,METAL FILM 75,1/2W
R2741	1-216-821-11	s RESISTOR,CHIP 1.0K 1/10W(1608)
R2742	1-216-843-11	s RESISTOR,CHIP 68K 1/10W (1608)
R2743	1-216-842-11	s RESISTOR,CHIP 56K 1/16W(1608)
R2744	1-216-821-11	s RESISTOR,CHIP 1.0K 1/10W(1608)
R2745	1-216-815-11	s RESISTOR,CHIP 330 1/10W 1608
R2750	1-214-911-11	s RESISTOR,METAL FILM 82K/1/2W
R2751	1-216-845-11	s RESISTOR,CHIP 100K 1/10W(1608)
R2752	1-216-854-11	s RESISTOR,CHIP 560K 1/16W 1608
R2753	1-216-849-11	s RESISTOR,CHIP 220K 1/16W 1608
R2754	1-216-835-11	s RESISTOR,CHIP 15K 1/10W
R2755	1-216-809-11	s RESISTOR,CHIP 100 1/10W 1608
R2760	1-214-911-11	s RESISTOR,METAL FILM 82K/1/2W
R2761	1-216-845-11	s RESISTOR,CHIP 100K 1/10W(1608)
R2762	1-216-854-11	s RESISTOR,CHIP 560K 1/16W 1608
R2763	1-216-849-11	s RESISTOR,CHIP 220K 1/16W 1608
R2764	1-216-835-11	s RESISTOR,CHIP 15K 1/10W
R2765	1-216-809-11	s RESISTOR,CHIP 100 1/10W 1608
R2770	1-214-911-11	s RESISTOR,METAL FILM 82K/1/2W
R2771	1-216-845-11	s RESISTOR,CHIP 100K 1/10W(1608)
R2772	1-216-854-11	s RESISTOR,CHIP 560K 1/16W 1608
R2773	1-216-849-11	s RESISTOR,CHIP 220K 1/16W 1608
R2774	1-216-835-11	s RESISTOR,CHIP 15K 1/10W
R2775	1-216-809-11	s RESISTOR,CHIP 100 1/10W 1608
R2782	1-216-821-11	s RESISTOR,CHIP 1.0K 1/10W(1608)
R2783	1-216-821-11	s RESISTOR,CHIP 1.0K 1/10W(1608)
R2784	1-216-815-11	s RESISTOR,CHIP 330 1/10W 1608
R2785	1-216-827-11	s RESISTOR,CHIP 3.3K 1/10W 1608
R2786	1-216-808-11	s RESISTOR,CHIP 82 1/16W 1608
R2788	1-216-821-11	s RESISTOR,CHIP 1.0K 1/10W(1608)
R2789	1-216-821-11	s RESISTOR,CHIP 1.0K 1/10W(1608)
R2790	1-216-821-11	s RESISTOR,CHIP 1.0K 1/10W(1608)
R2793	1-216-821-11	s RESISTOR,CHIP 1.0K 1/10W(1608)
R2794	1-216-821-11	s RESISTOR,CHIP 1.0K 1/10W(1608)
R2795	1-216-821-11	s RESISTOR,CHIP 1.0K 1/10W(1608)
R2796	1-216-821-11	s RESISTOR,CHIP 1.0K 1/10W(1608)
R2797	1-216-821-11	s RESISTOR,CHIP 1.0K 1/10W(1608)
R3770	1-216-833-11	s RESISTOR,CHIP 10K 1/10W (1608)
R3771	1-216-833-11	s RESISTOR,CHIP 10K 1/10W (1608)
R3772	1-216-833-11	s RESISTOR,CHIP 10K 1/10W (1608)
R3773	1-216-833-11	s RESISTOR,CHIP 10K 1/10W (1608)
R3774	1-216-833-11	s RESISTOR,CHIP 10K 1/10W (1608)
R3775	1-216-833-11	s RESISTOR,CHIP 10K 1/10W (1608)
R3776	1-216-833-11	s RESISTOR,CHIP 10K 1/10W (1608)
R3777	1-216-841-11	s RESISTOR,CHIP 47K 1/10W 1608
R3778	1-216-841-11	s RESISTOR,CHIP 47K 1/10W 1608
R3779	1-216-841-11	s RESISTOR,CHIP 47K 1/10W 1608
R3780	1-216-841-11	s RESISTOR,CHIP 47K 1/10W 1608
R3781	1-216-841-11	s RESISTOR,CHIP 47K 1/10W 1608
R3782	1-216-841-11	s RESISTOR,CHIP 47K 1/10W 1608
R3783	1-216-841-11	s RESISTOR,CHIP 47K 1/10W 1608
R3784	1-216-839-11	s RESISTOR,CHIP 33K 1/10W 1608
R3790	1-214-837-11	s RESISTOR,METAL FILM 75,1/2W
R3791	1-216-821-11	s RESISTOR,CHIP 1.0K 1/10W(1608)
R3792	1-216-841-11	s RESISTOR,CHIP 47K 1/10W 1608
R3793	1-216-836-11	s RESISTOR,CHIP 18K 1/10W 1608

(Q BOARD)

Ref. No. or Q'ty	Part No.	SP Description
R3794	1-216-821-11	s RESISTOR,CHIP 1.0K 1/10W(1608)
R3795	1-216-815-11	s RESISTOR,CHIP 330 1/10W 1608

X BOARD

Ref. No. or Q'ty	Part No.	SP Description
1pc	A-1401-776-A	s MOUNTED CIRCUIT BOARD, X
CN001	1-564-719-11	o PIN,CONNECTOR (3P)
D001	8-719-023-78	s LED SEL3810DLC05
D002	8-719-023-78	s LED SEL3810DLC05
D003	8-719-023-78	s LED SEL3810DLC05

PACKING MATERIALS & SUPPLIED ACCESSORIES

Ref. No. or Q'ty	Part No.	SP Description
1pc	4-384-927-11	o BAG,PROTECTION (POLYETHYLENE)
1pc	2-990-242-01	s HOLDER (B),PLUG
1pc	4-092-824-02	s OPERATING INSTRUCTIONS (JAPAN, ENGLISH, FRENCH, GERMAN, SPANISH, ITALIAN, SIMPLIFIED CHINESE)

Section 8
Block Diagrams

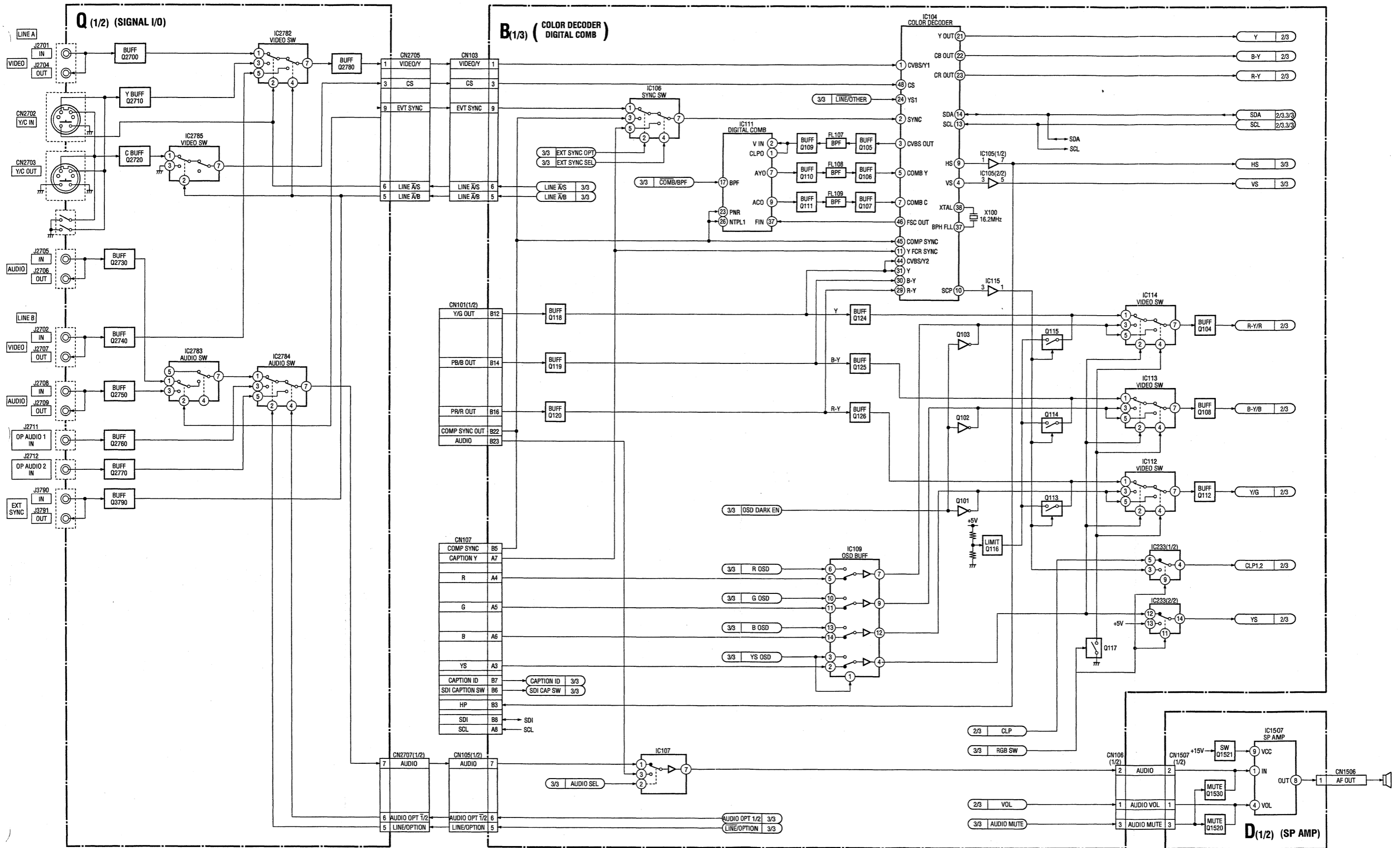

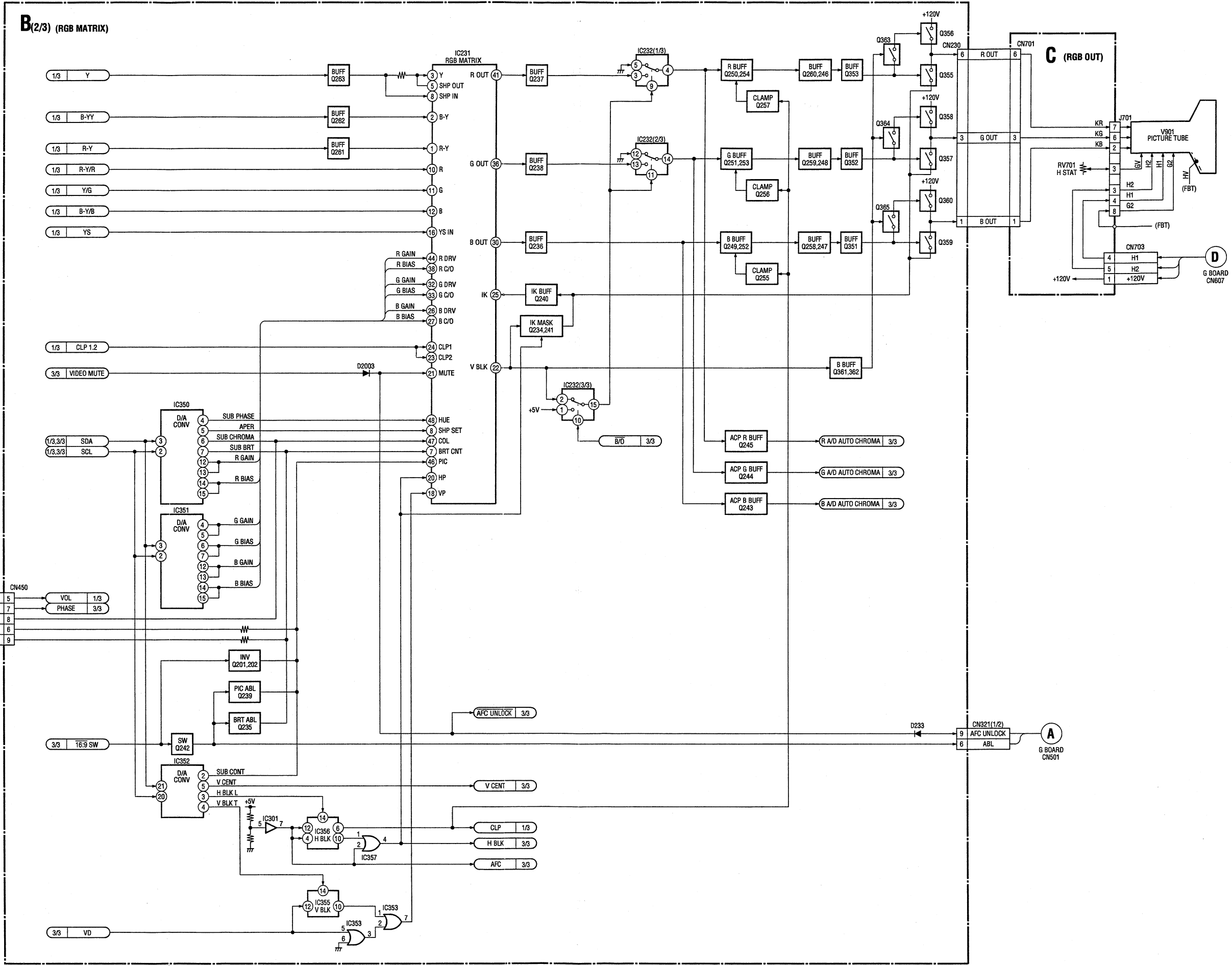

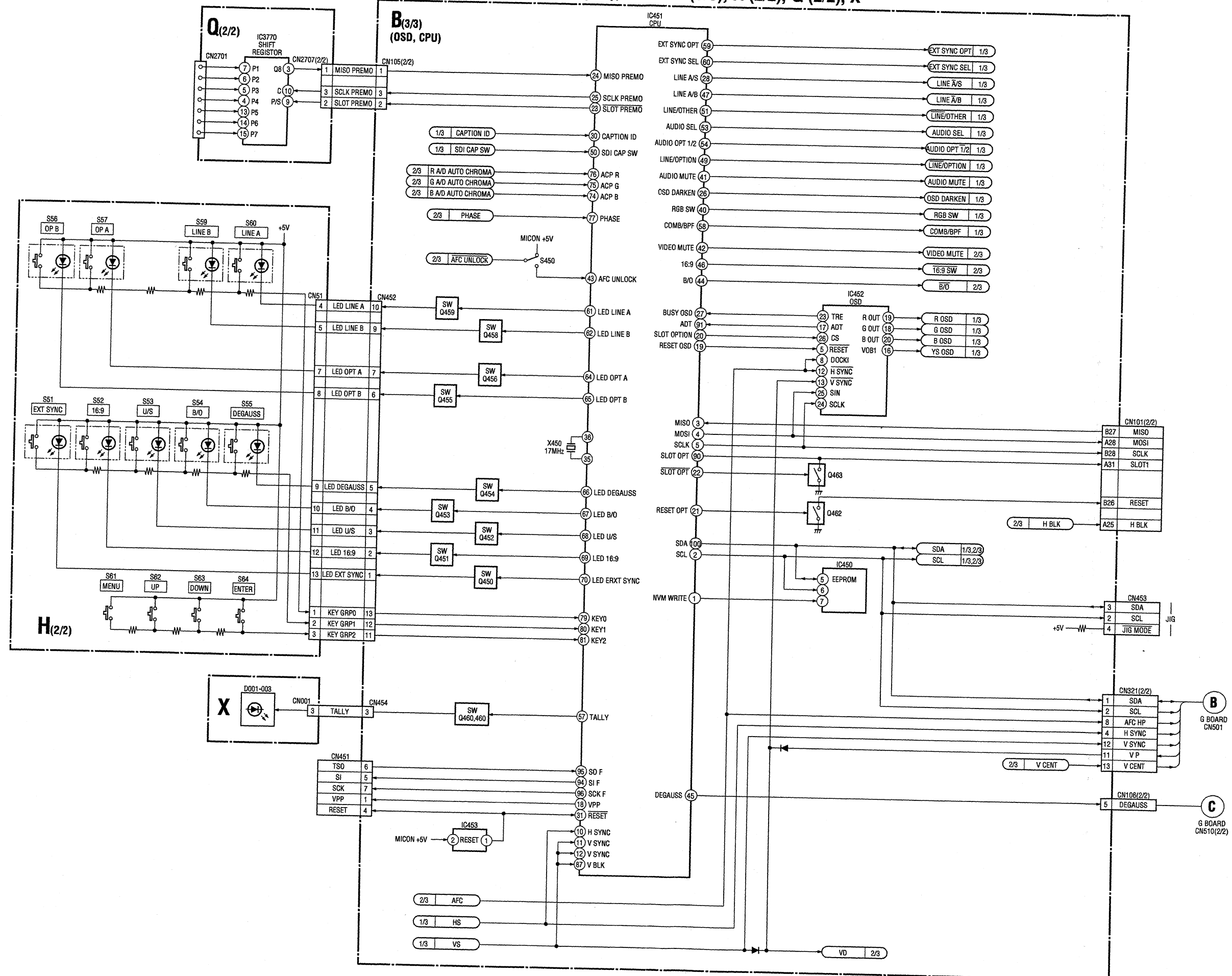

B (3/3), H (2/2), Q (2/2), X B (3/3), H (2/2), Q (2/2), X

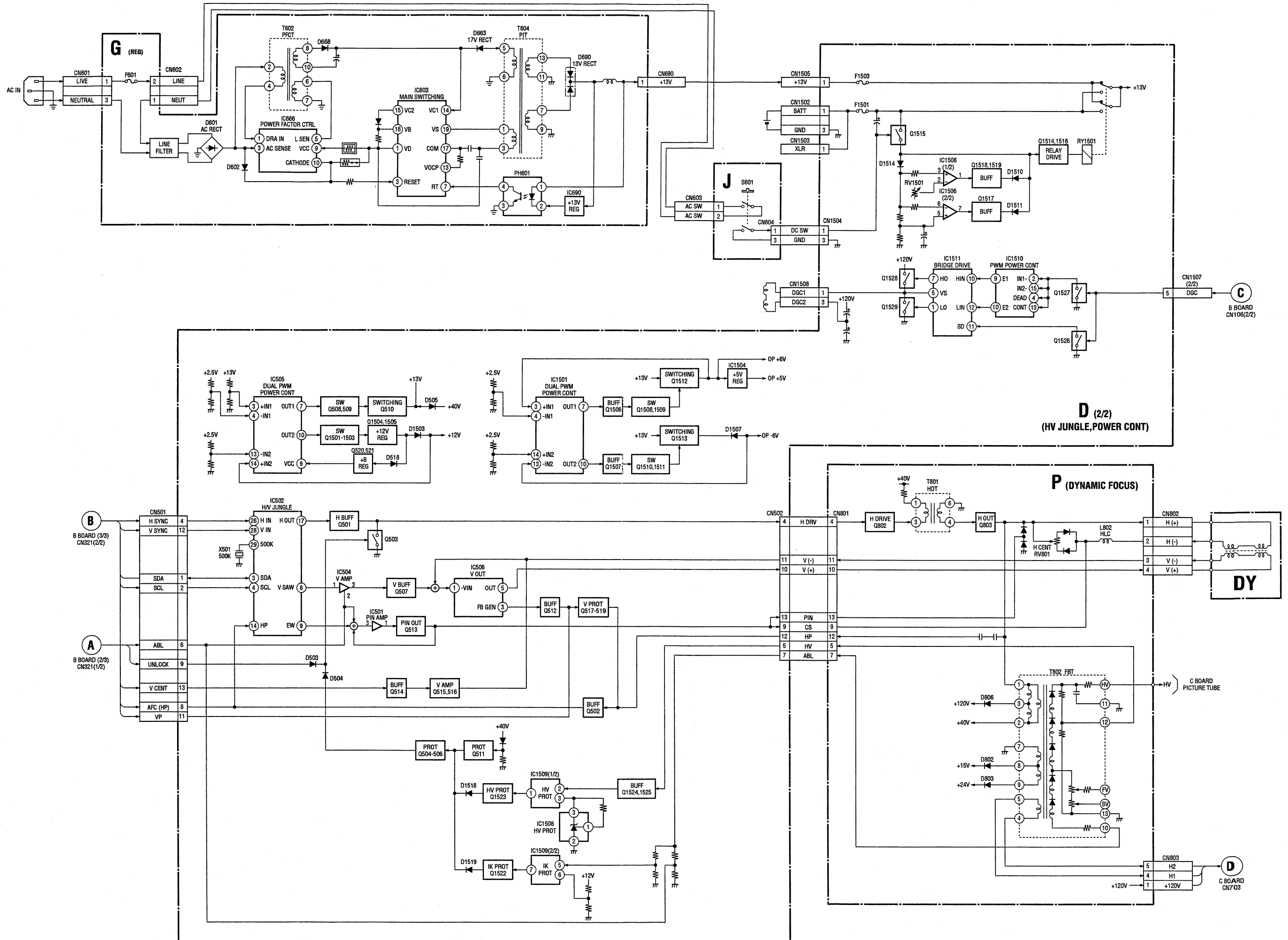



Section 9 Diagrams



Note:

- Parts marked “ * ” differ according to the model/destination. Refer to the mount table for each function.
- The parts marked “ # ” on schematic diagrams are not mounted.
- All capacitors are in μF unless otherwise noted. pF: $\mu\mu\text{F}$ 50WV or less are not indicated except for electrolytics.
- All electrolytics are in 50 V unless otherwise specified.
-  : fusible resistor
-  : nonflammable resistor
- Δ : internal component
-  : panel designation and adjustment for repair
- Caution when replacing chip parts
New parts must be attached after removal of the chip.
Be careful not to heat the minus side of a tantalum capacitor, because it is easily damaged by the heat.

Reference information

RESISTOR	RN	: METAL FILM
	RC	: SOLID
	FPRD	: NONFLAMMABLE CARBON
	FUSE	: NONFLAMMABLE FUSIBLE
	RS	: NONFLAMMABLE METAL OXIDE
	RB	: NONFLAMMABLE CEMENT
	RW	: NONFLAMMABLE WIREWOUND
	※	: ADJUSTMENT RESISTOR
COIL	LF-8L	: MICRO INDUCTOR
CAPACITOR	TA	: TANTALUM
	PS	: STYROL
	PP	: POLYPROPYLENE
	PT	: MYLAR
	MPS	: METALIZED POLYESTER
	MPP	: METALIZED POLYPROPYLENE
	ALB	: BIPOLAR
	ALT	: HIGH TEMPERATURE
ALR	: HIGH RIPPLE	

[Measuring conditions, voltage and waveform]



- A voltage value is the reference value between the measurement point and the earth, when the NTSC color bar signal is received from the color bar generator. (digital multi-meter used: 10 M ohms/ V DC)
- Unit of voltage is V (volt).
(Voltage variations may occur due to normal production tolerances.)
-  : B+ line
-  : B- line
- No mark : NTSC (3.58 MHz) color bar signal.
- \star : Measurement disabled.
- Circled numbers indicate the reference waveform.
-  : Signal path.

The components identified marked Δ are critical for safety. Replace only with the part number specified.

Les composants identifiés par la marque Δ sont critiques pour la sécurité. Ne les remplacer que par une pièce portant le numéro spécifié.



NOTE:
The circuit indicated as shown on the left contains high voltages of over 600 Vp-p. Take care to avoid electric shock during inspection or repair work.

- The components marked  in this schematic diagram have been carefully factory-selected for each set in order to satisfy regulations regarding X-ray radiation.
When replacing components marked , make the necessary adjustments indicated. If results do not meet the specified value, change the component marked  and repeat the adjustment until the specified value is achieved.
- When replacing a part shown in the table below, be sure to perform the related adjustment.

9-1. Schematic Diagrams and Printed Wiring Boards

Q BOARD

*:B SIDE

D2700	* D-2
D2710	* E-2
D2720	* E-1
D2730	* D-2
D2740	* B-2
D2750	* B-2
D2760	* A-1
D2770	* A-1
D3790	* A-2
D3791	* A-2
IC2782	* D-1
IC2783	* C-1
IC2784	* B-1
IC2785	* C-1
IC3770	* C-2
Q2700	* D-2
Q2710	* E-1
Q2720	* D-1
Q2730	* D-2
Q2740	* B-2
Q2750	* B-2
Q2760	* A-1
Q2770	* A-1
Q2780	* D-1
Q3790	* B-2

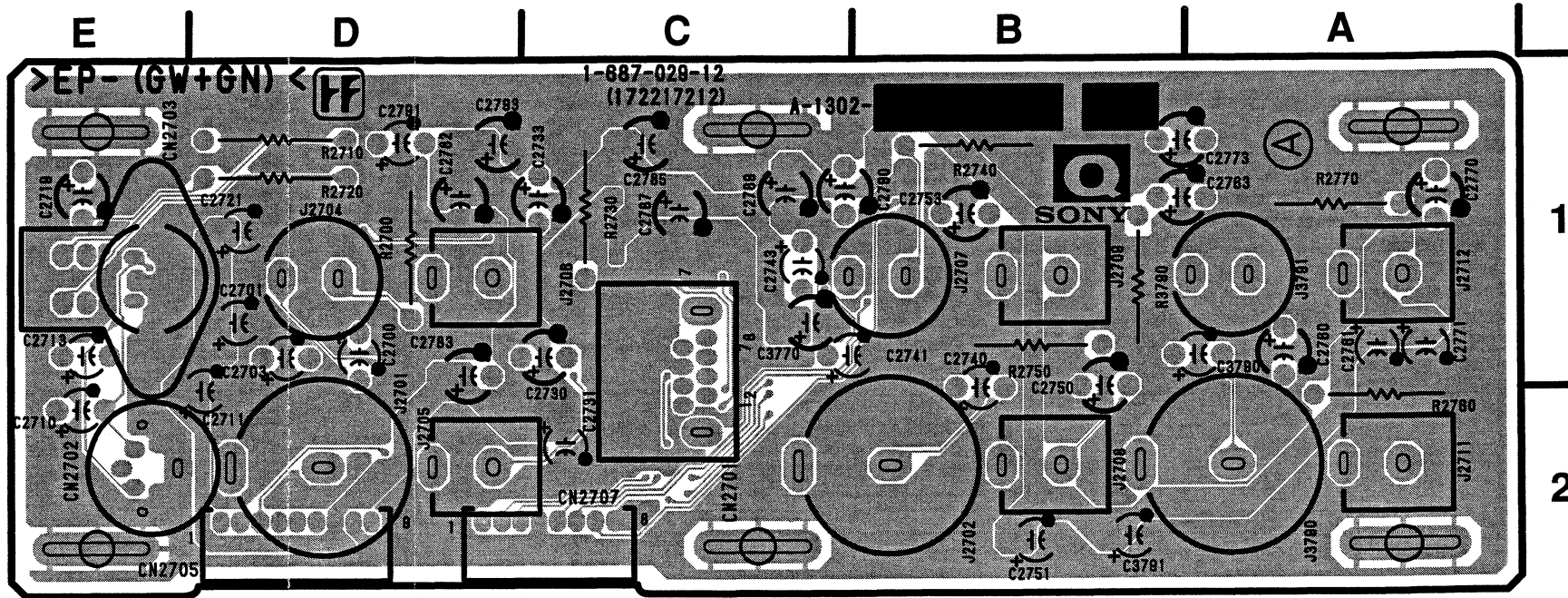

Q -A SIDE-
SUFFIX: -12

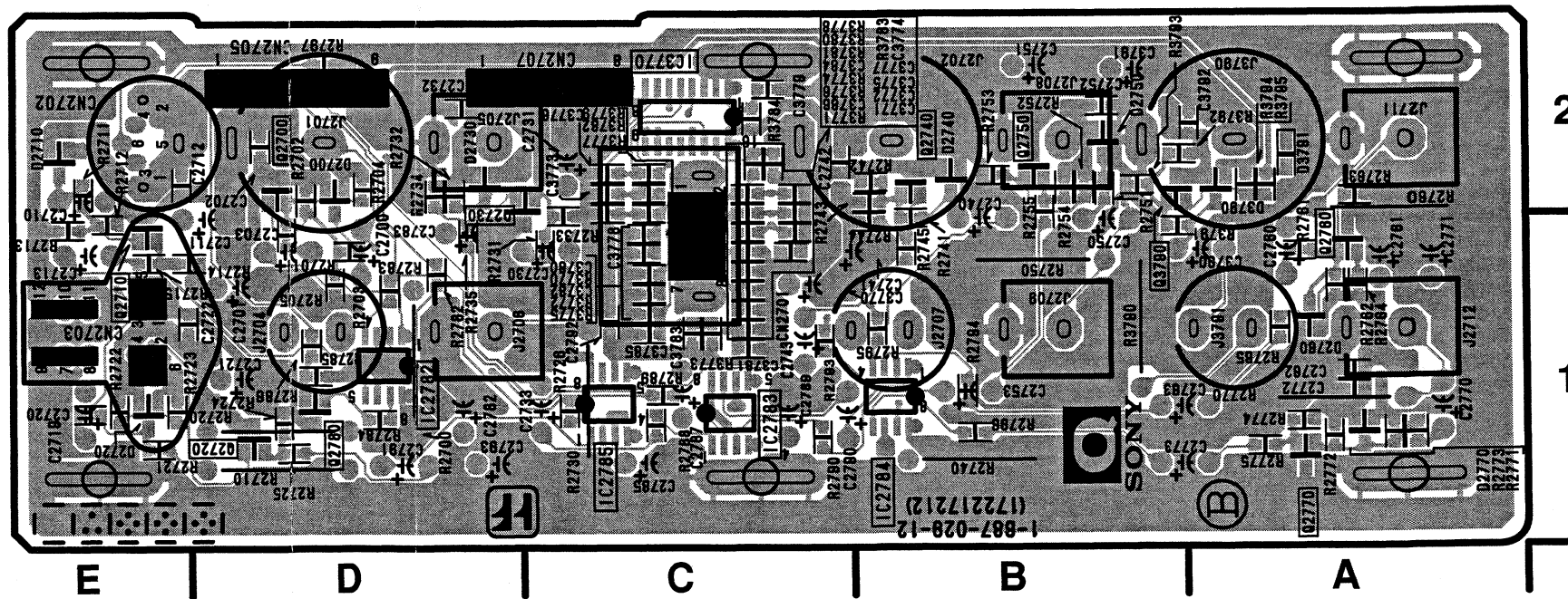

Q -B SIDE-
SUFFIX: -12

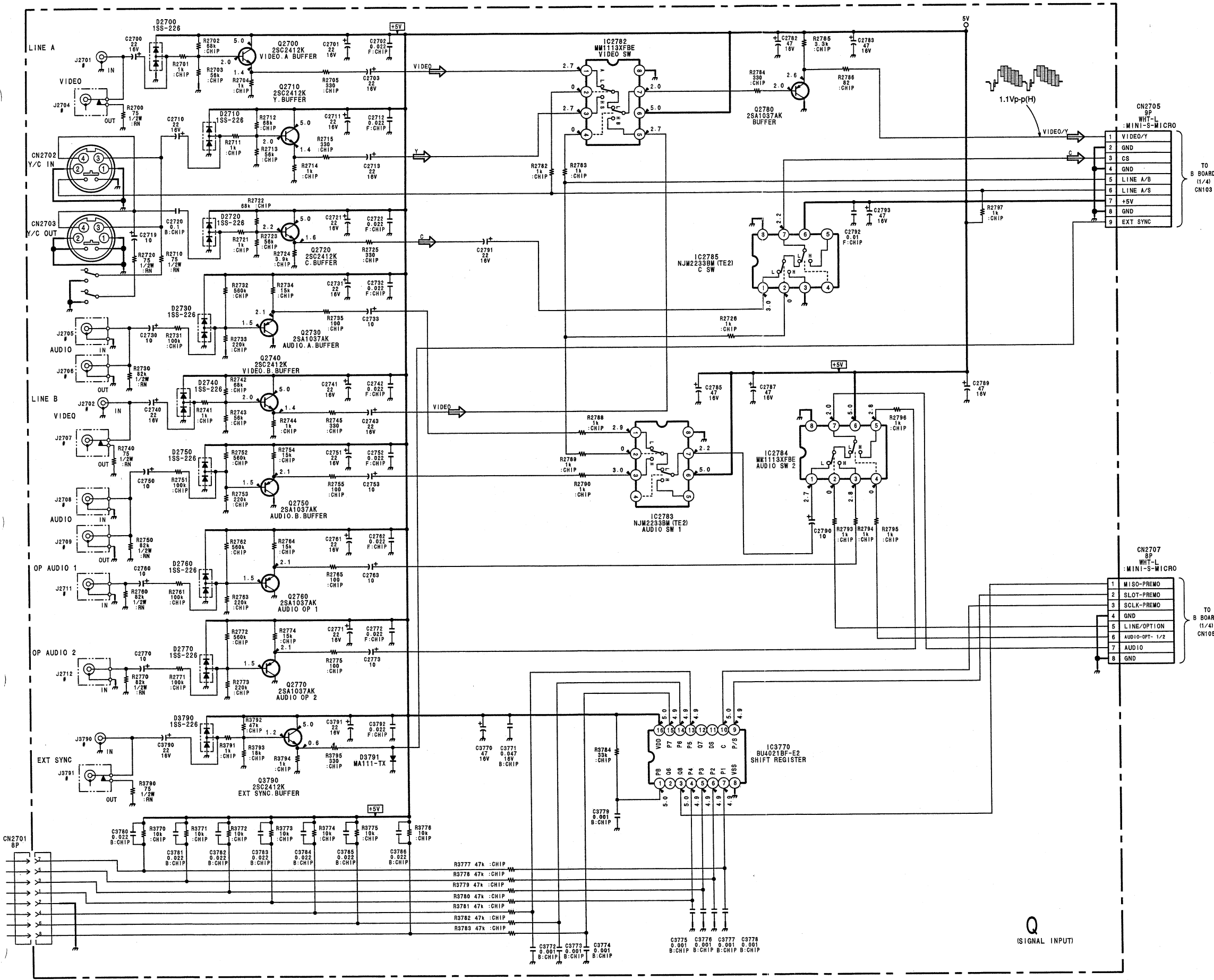

Q BU4021BF-E2 (IC3770)

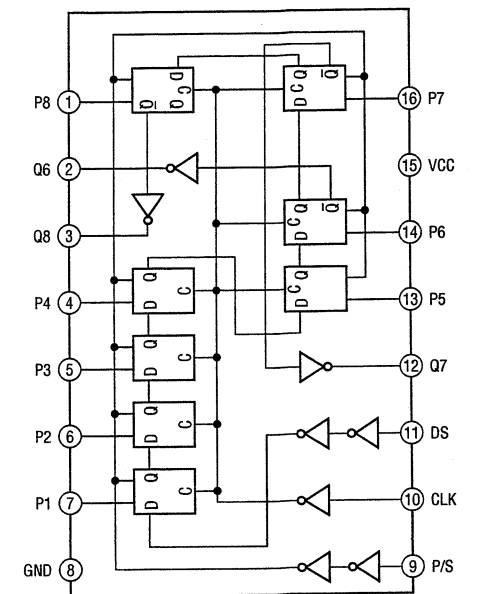

- 1
- 2
- 3
- 4
- 5

(B-SS9719-WW-UC-Q)

B BOARD

*:B SIDE

D201	*E-4	Q101	*D-4	Q459	A-4
D202	*E-4	Q102	*D-4	Q460	*A-5
D230	B-3	Q103	*D-4	Q461	*A-5
D231	*B-3	Q104	C-3	Q462	*B-4
D232	B-3	Q105	*D-4	Q463	*B-4
D233	B-3	Q106	*D-3	Q501	C-1
D234	C-4	Q107	*D-4	Q502	C-1
D235	C-4	Q108	*C-2	Q503	*C-1
D236	*B-3	Q109	*D-4	Q7201	*D-1
D237	*A-3	Q110	*D-4		
D238	A-3	Q111	*D-4	TP101	D-2
D239	*A-3	Q112	C-2	TP102	D-3
D301	*D-5	Q113	*C-2	TP103	B-4
D350	*B-2	Q114	*C-2	TP104	D-2
D351	*B-1	Q115	*C-1	TP105	D-3
D352	*B-1	Q116	*C-1	TP106	D-3
D353	B-1	Q117	*C-2	TP107	D-3
D354	B-1	Q118	*C-1	TP111	D-4
D355	A-1	Q119	*C-1	TP112	D-3
D356	A-1	Q120	*C-1	TP113	D-4
D357	B-1	Q121	*D-2	TP114	A-1
D358	*A-1	Q122	*D-2	TP115	E-1
D359	A-1	Q123	*D-2	TP116	C-3
D360	*A-1	Q124	*C-1	TP117	E-5
D361	B-2	Q125	*C-2	TP230	B-2
D362	B-2	Q126	*C-2	TP350	B-2
D363	*A-2	Q130	*D-3	TP351	B-2
D364	*A-2	Q131	*D-3	TP352	B-1
D365	*A-1	Q132	*E-3	TP353	B-2
D366	A-1	Q201	B-4		
D367	A-1	Q202	C-4		
D368	A-1	Q233	B-3		
D369	A-2	Q234	*A-3		
D401	*B-5	Q235	C-5		
D450	A-5	Q236	*B-3		
D451	A-4	Q237	*A-3		
D452	A-4	Q238	*A-3		
D453	*A-4	Q239	C-4		
D454	A-4	Q240	*B-3		
D455	*A-4	Q241	*B-3		
D456	A-4	Q242	C-4		
D457	*A-4	Q243	*A-3		
D458	*A-5	Q244	*A-3		
D459	A-4	Q245	A-3		
D460	A-4	Q246	C-1		
D461	*A-4	Q247	C-2		
D462	A-4	Q248	C-2		
D463	*A-5	Q249	A-3		
D464	*A-4	Q250	A-3		
D465	*A-5	Q251	*A-2		
D466	*B-5	Q252	A-3		
		Q253	*A-2		
IC101	C-1	Q254	A-3		
IC102	D-1	Q255	*A-3		
IC104	D-2	Q256	A-2		
IC105	D-2	Q257	A-3		
IC106	D-1	Q258	A-3		
IC107	E-4	Q259	*A-2		
IC108	D-4	Q260	*A-3		
IC109	D-4	Q261	*D-2		
IC111	D-3	Q262	D-2		
IC112	C-2	Q263	*D-2		
IC113	C-2	Q350	D-5		
IC114	C-3	Q351	B-2		
IC115	C-1	Q352	B-1		
IC231	B-3	Q353	B-1		
IC232	A-2	Q354	D-5		
IC233	C-4	Q355	A-1		
IC301	D-5	Q356	A-1		
IC350	C-4	Q357	A-1		
IC351	C-4	Q358	B-1		
IC352	D-3	Q359	A-2		
IC353	C-5	Q360	A-2		
IC354	D-5	Q361	A-1		
IC355	C-5	Q362	A-1		
IC356	D-5	Q363	A-1		
IC357	D-5	Q364	A-1		
IC401	C-5	Q365	*A-2		
IC450	B-3	Q450	*A-4		
IC451	B-4	Q451	*A-4		
IC452	B-5	Q452	A-4		
IC453	B-5	Q453	A-4		
IC7201	C-1	Q454	*A-4		
IC7202	D-1	Q455	A-4		
IC7203	D-2	Q456	A-4		
IC7204	D-2	Q457	A-4		
IC7205	*D-1	Q458	A-4		

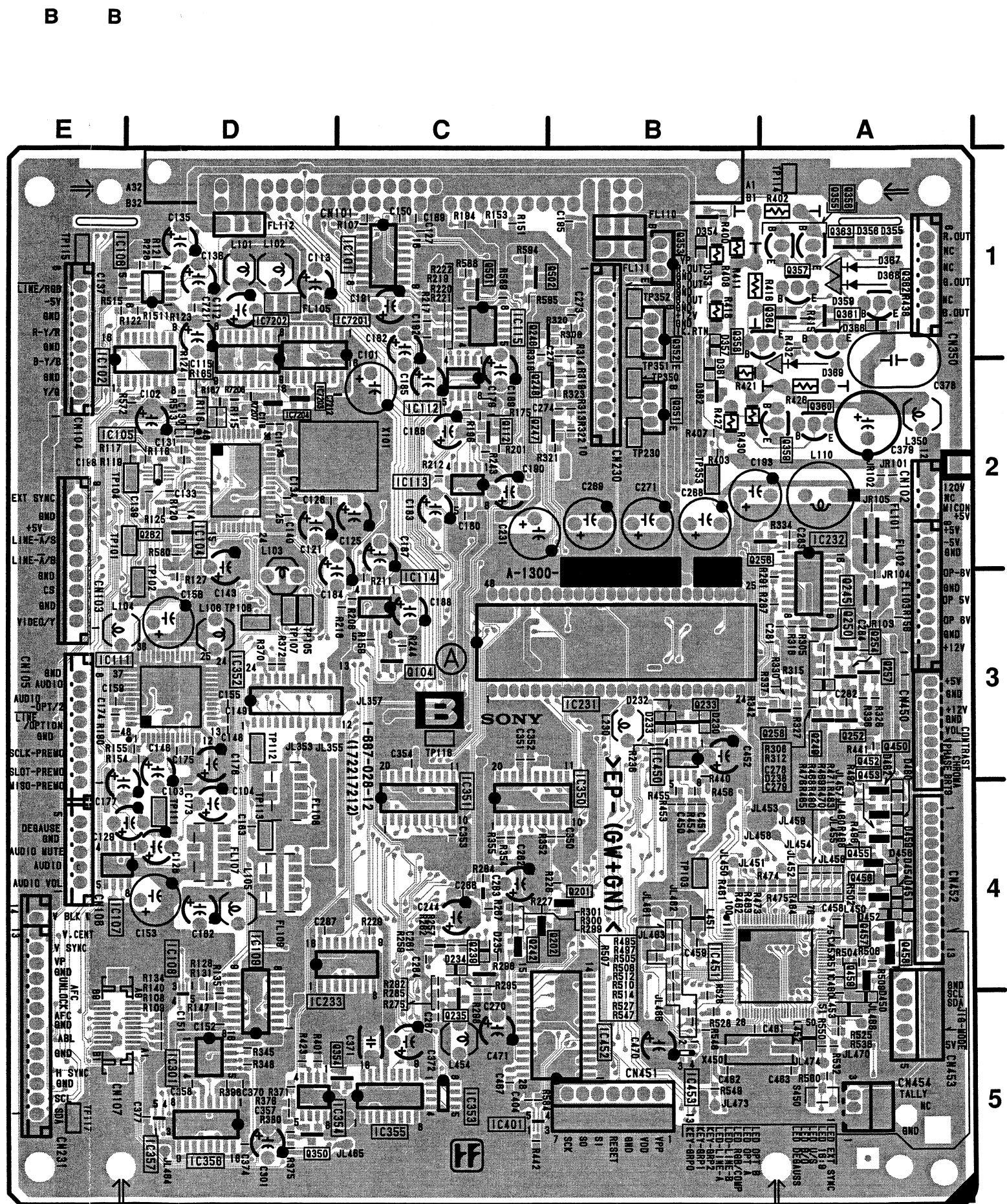

B - A SIDE-
SUFFIX: -12

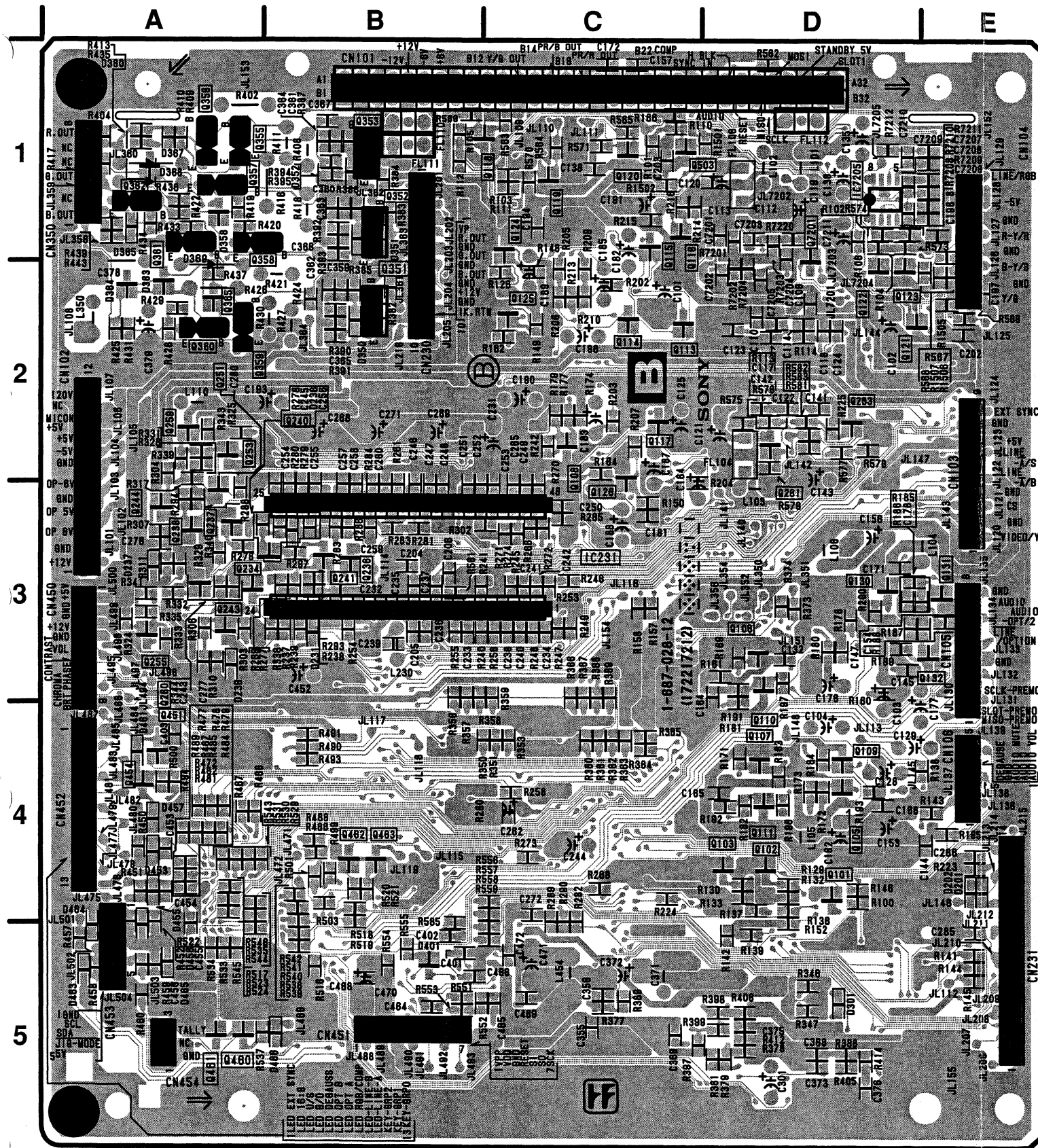

B - B SIDE-
SUFFIX: -12

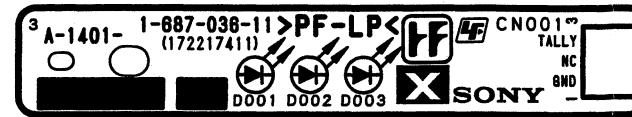

X - A SIDE-
SUFFIX: -11



X - B SIDE-
SUFFIX: -11

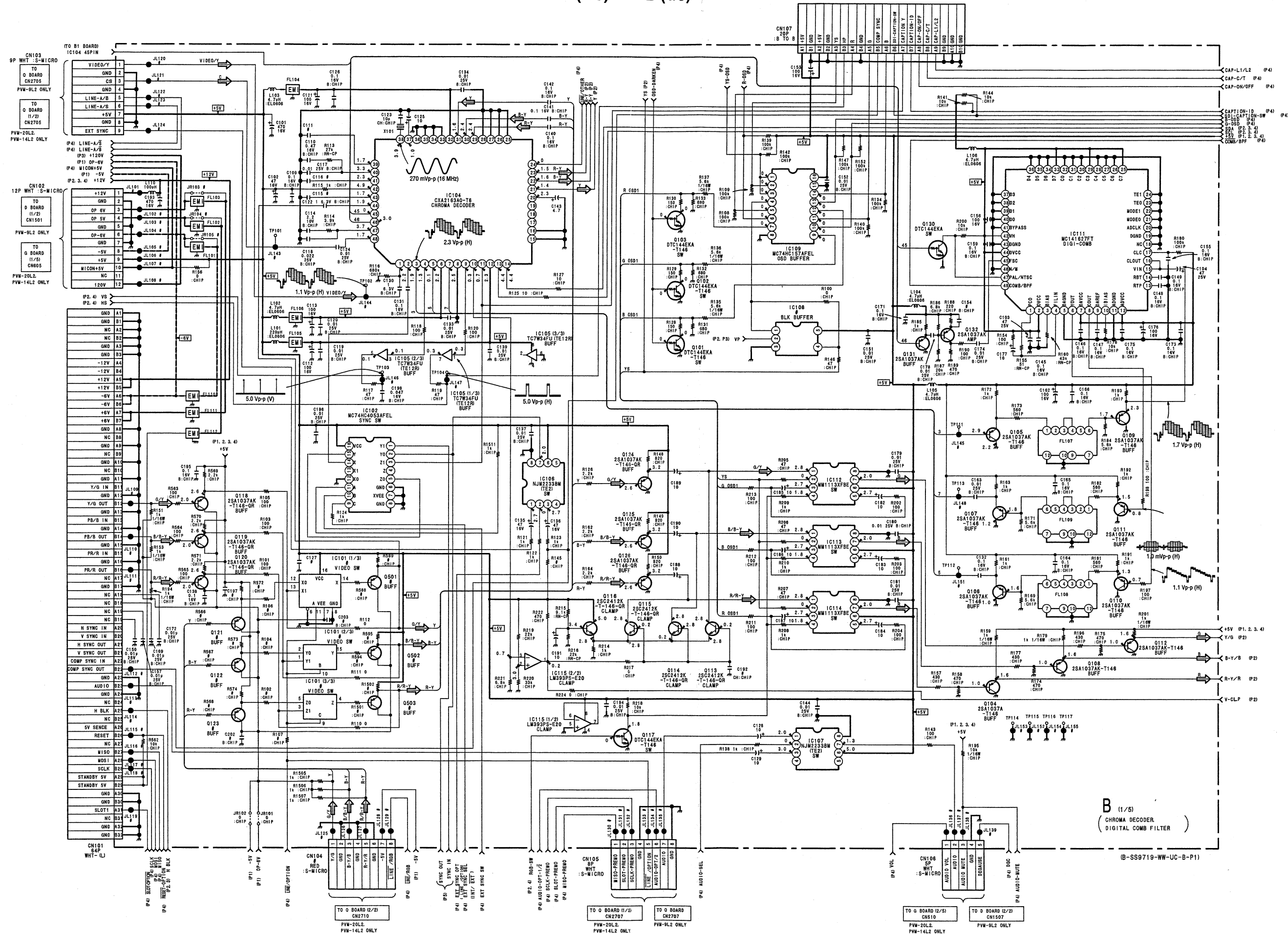

B (1/5)
(CHROMA DECODER
DIGITAL COMB FILTER)

(B-SS9719-WW-UC-B-P1)

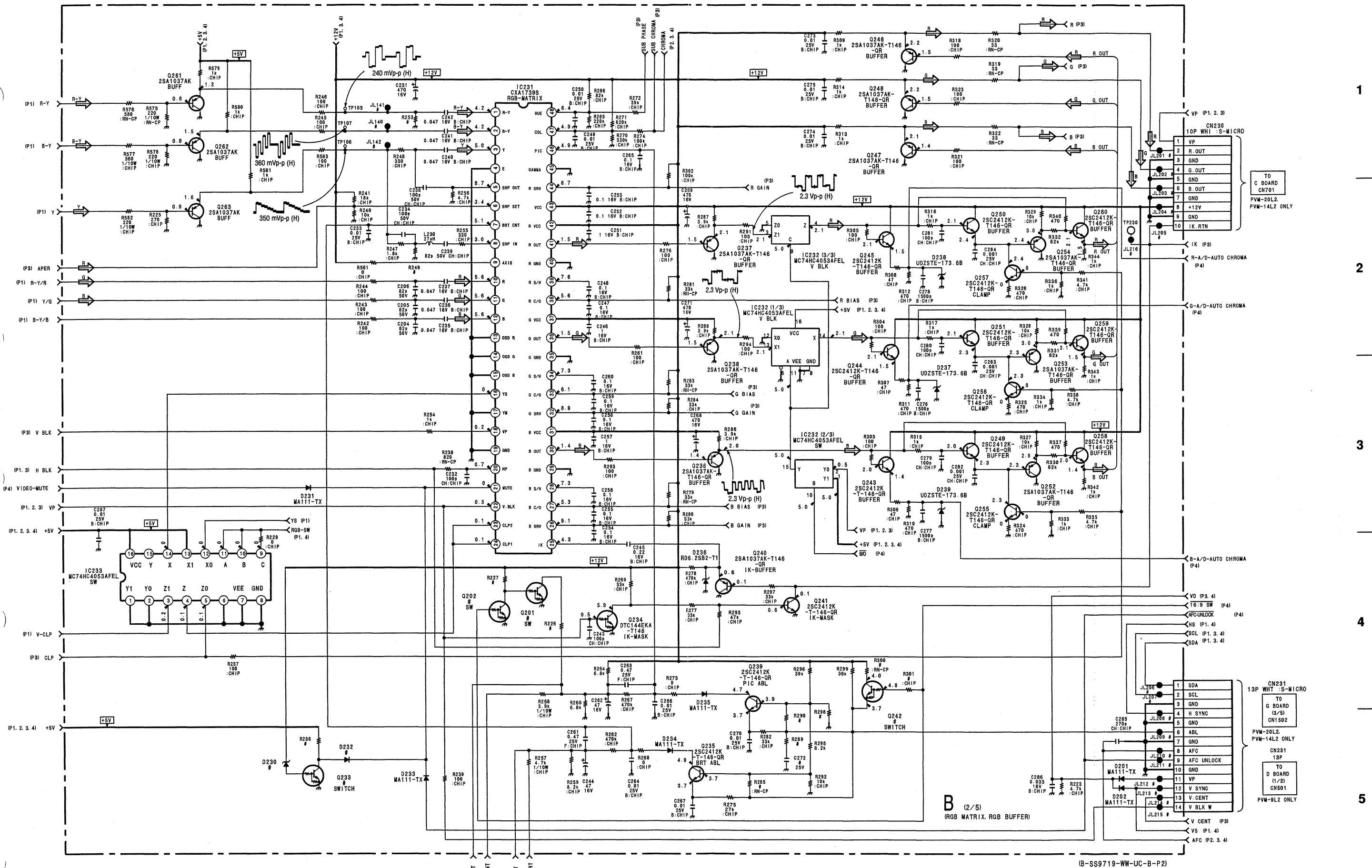

1
2
3
4
5

(B-SS9719-WW-UC-B-P2)

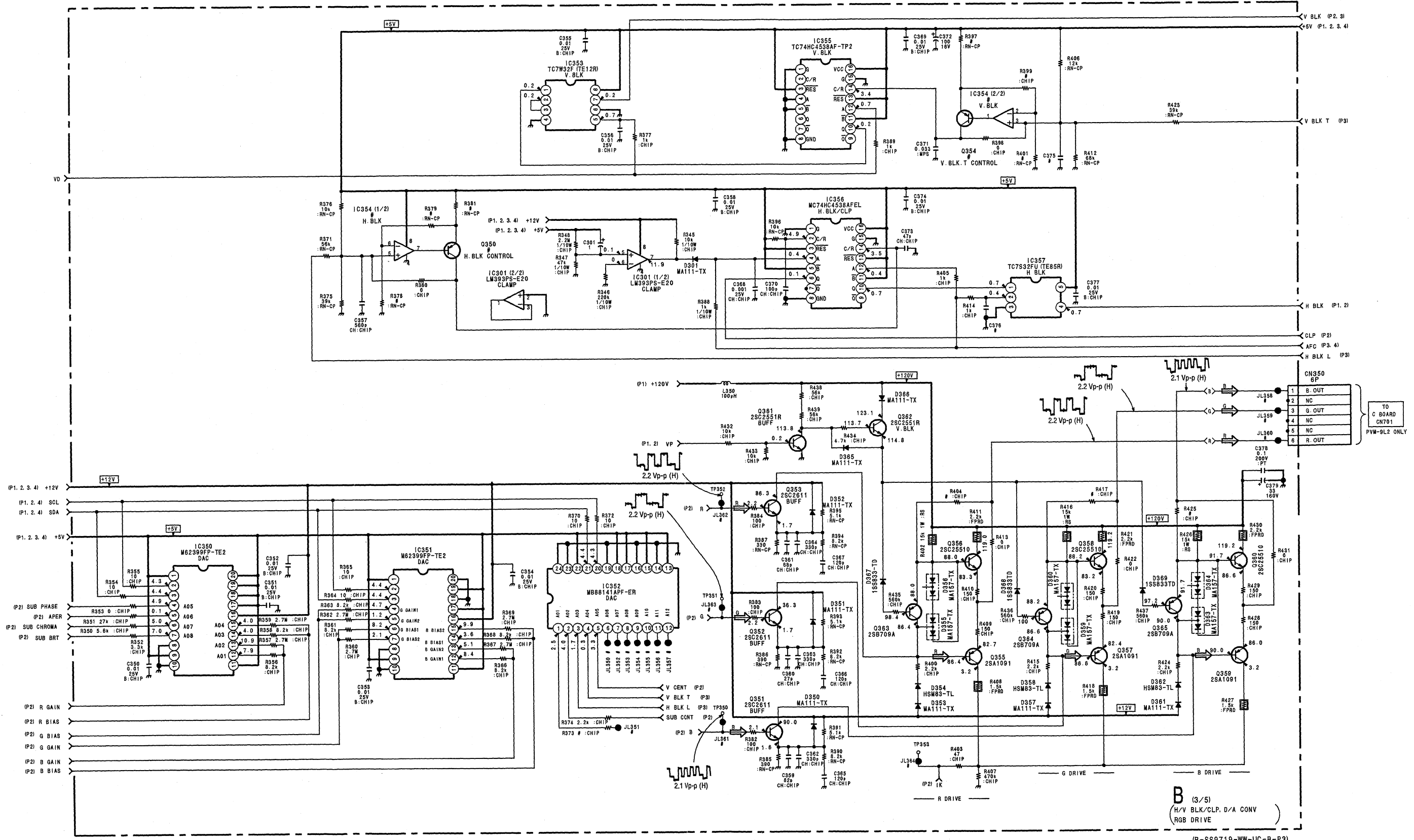

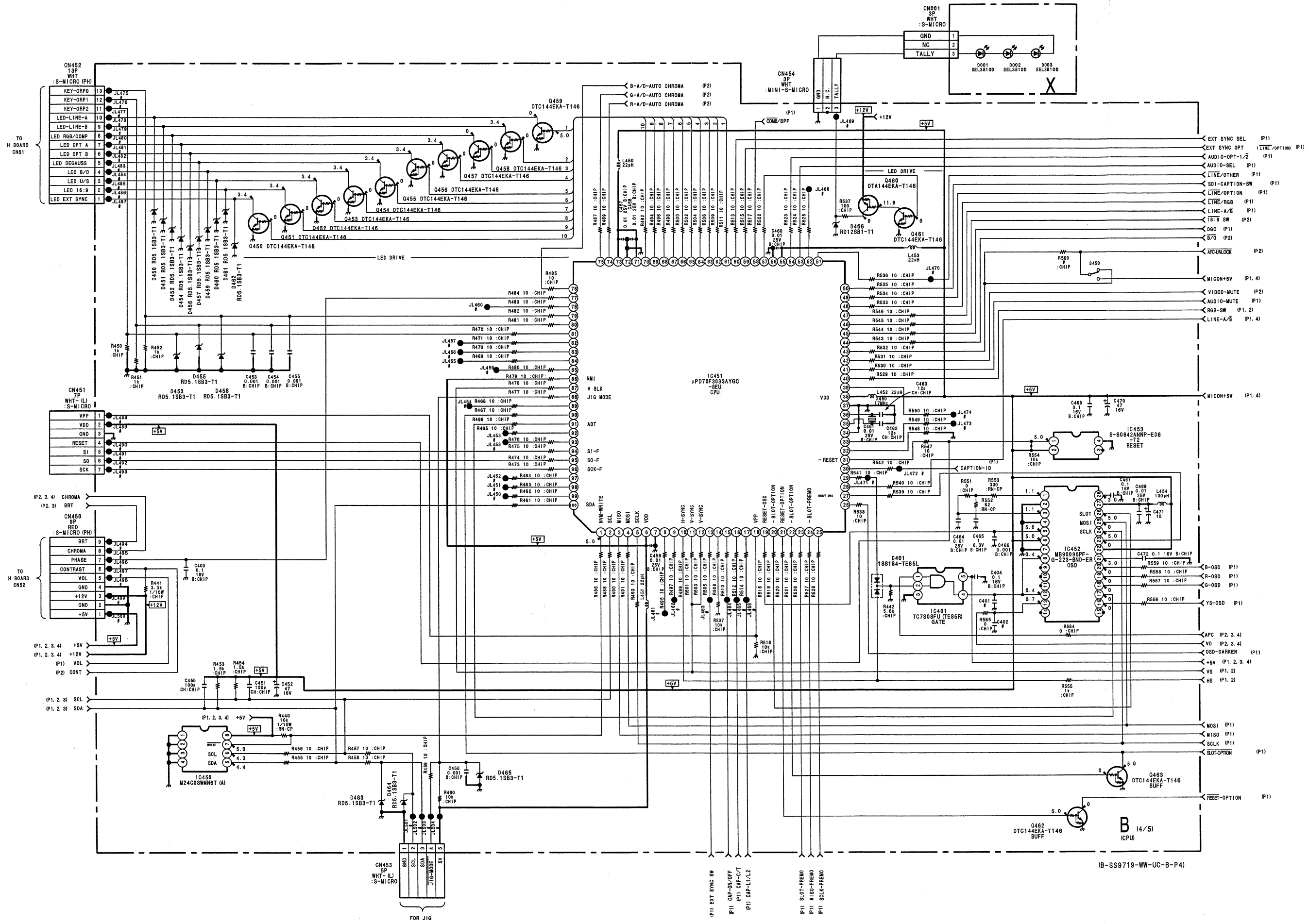

1
2
3
4
5

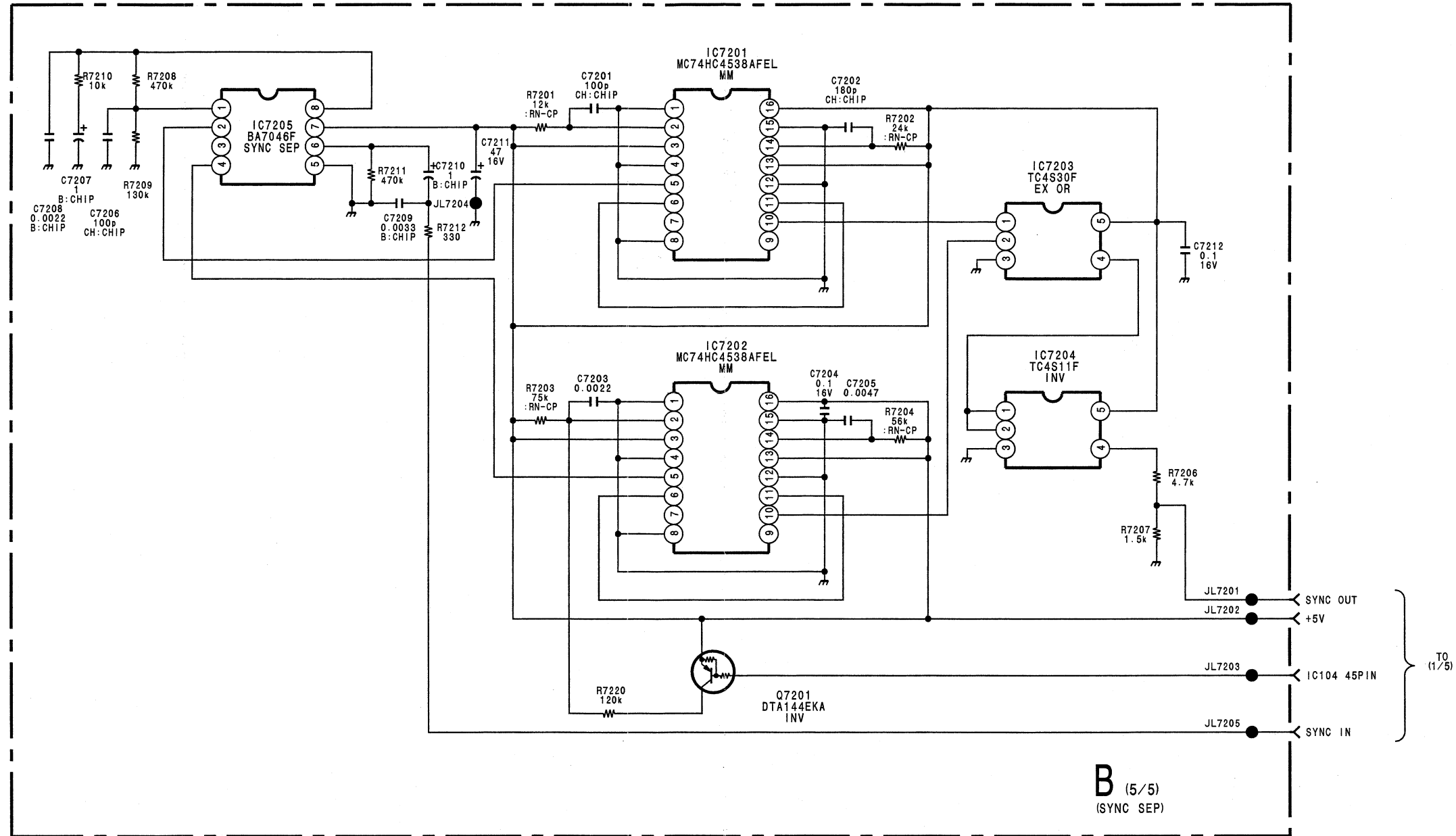

B (5/5)
(SYNC SEP)

(B-SS9719-WW-UC-B-P5)

B (5/5) BA7046F (IC7205)

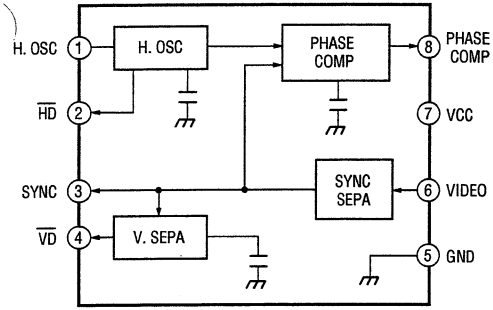

B (1/5) CXA2163AQ-T6 (IC104)

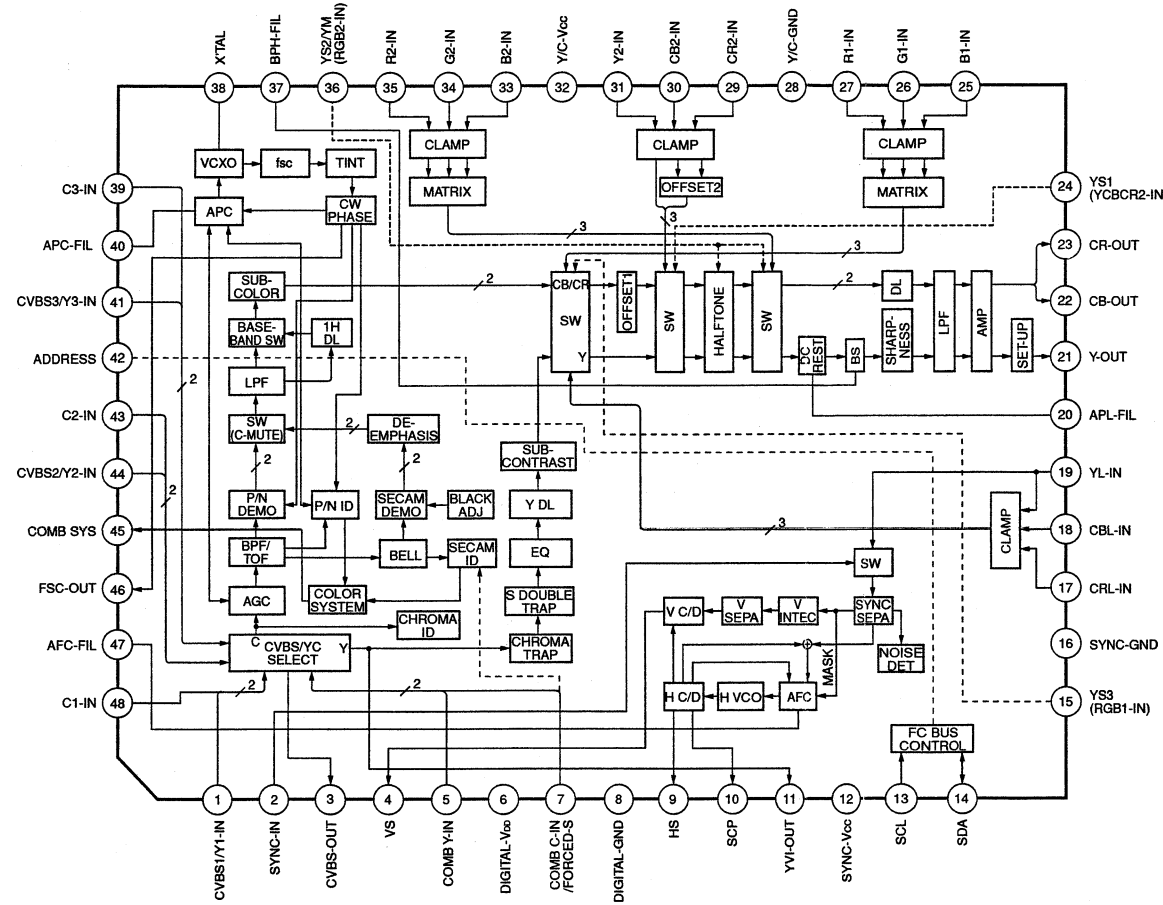

B (3/5) MB88141APF-ER (IC352)

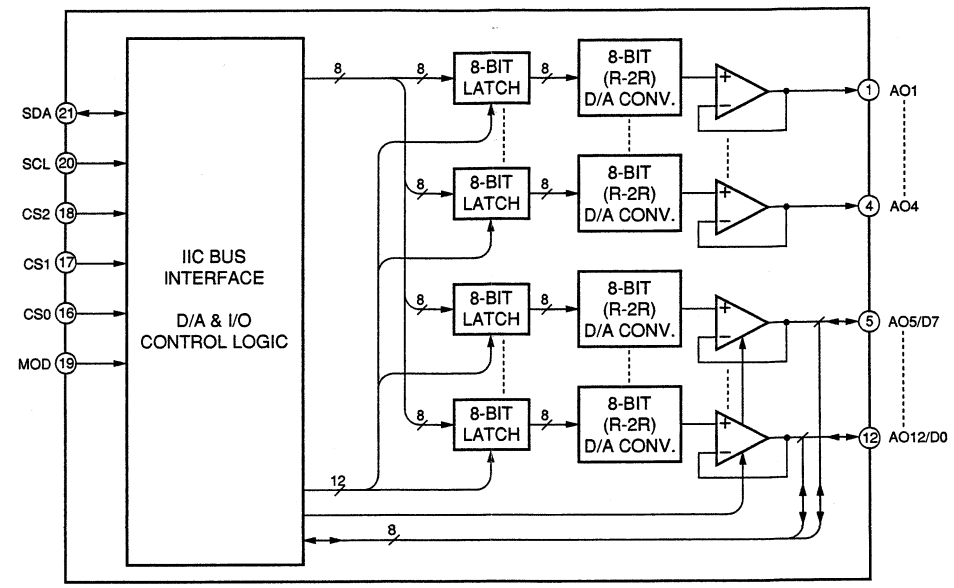

B (2/5) CXA1739S (IC231)

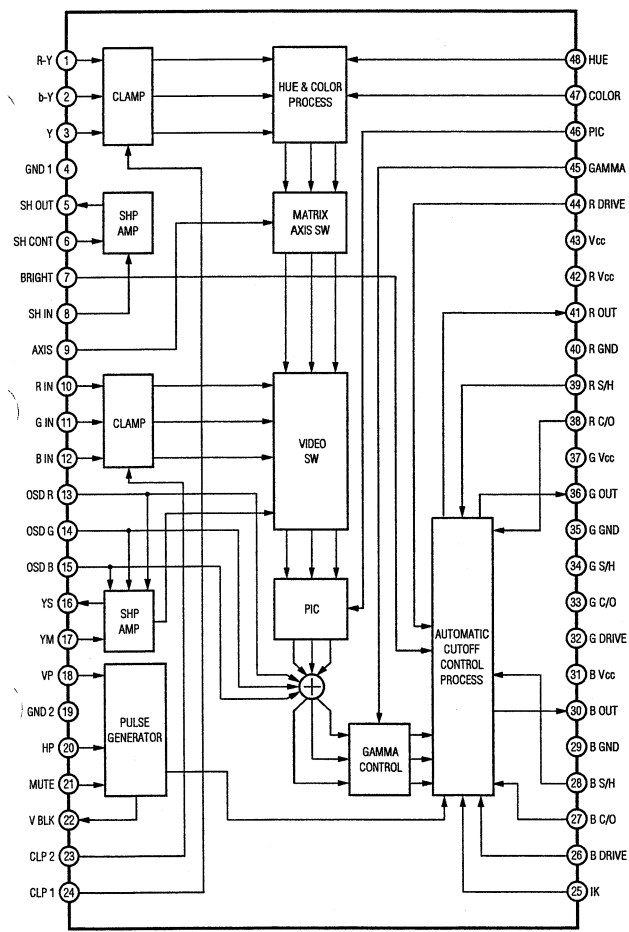

B (3/5) M62399FP-TE2 (IC350, IC351)

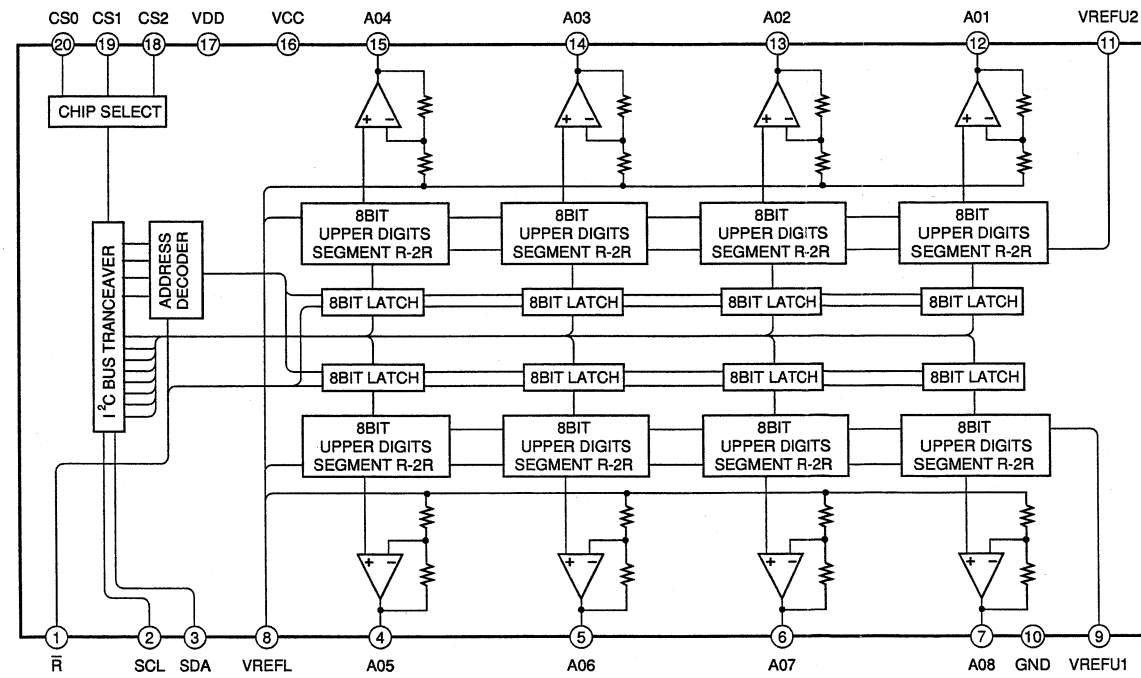

B (1/5) MC14162FT (IC111)

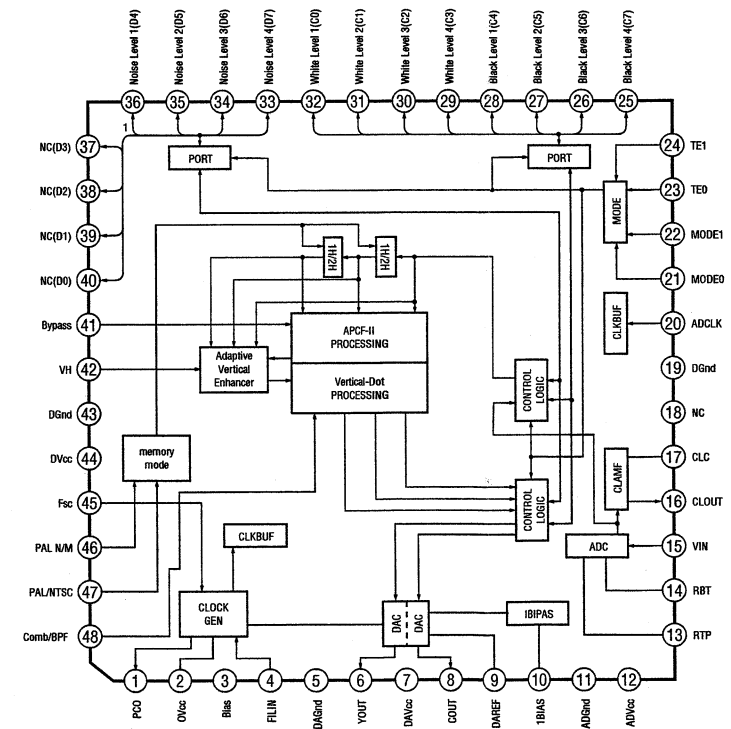

B (1/5) MC74HC157AFEL (IC109)

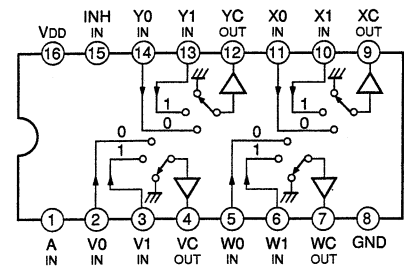

B (1/5, 2/5) MC74HC4053AFEL (IC102, IC233)

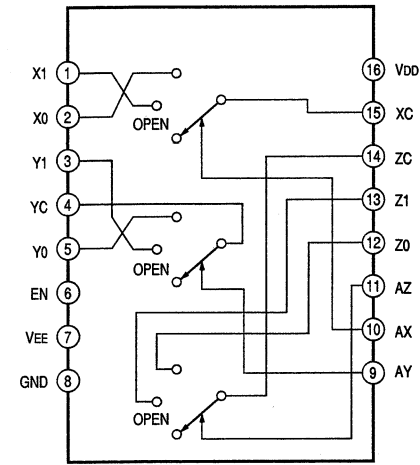

B (3/5, 5/5) MC74HC4538AFEL (IC356, IC7201, IC7202)

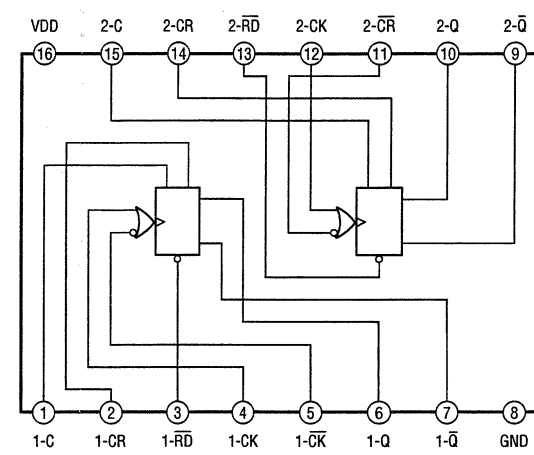

B (1/5) MM1113XFBE (IC112, IC113, IC114)

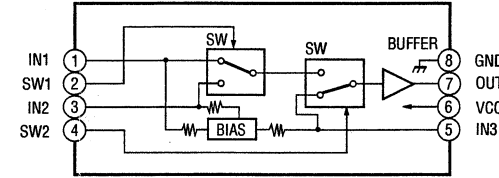

B (1/5) NJM2233BM (TE2) (IC106, IC107)

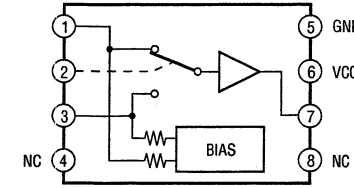

B (4/5) S-80842ANNP-ED6-T2 (IC453)

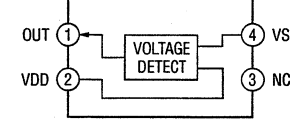

B (5/5) TC4S11F (IC7204)

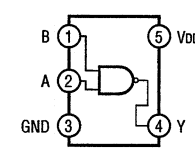

B (5/5) TC4S30F (IC7203)

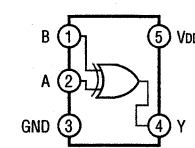

B (3/5) TC74HC4538AF-TP2 (IC355)

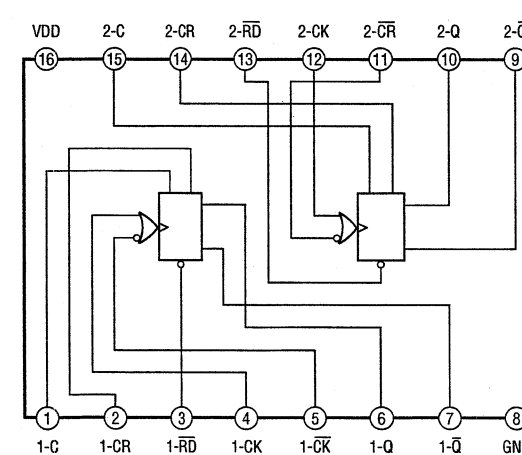

B (3/5) TC7S32FU (TE85R) (IC357)

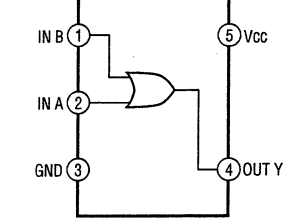

B (3/5) TC7W32F (TE12R) (IC353)

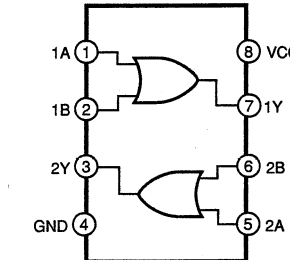

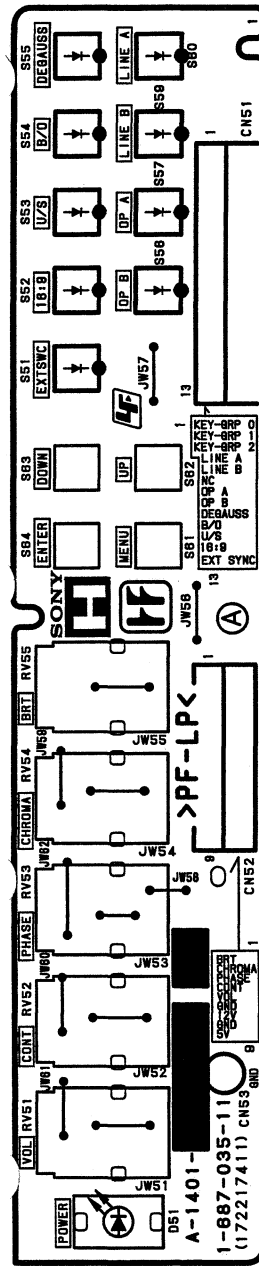

H - A SIDE-
SUFFIX: -11

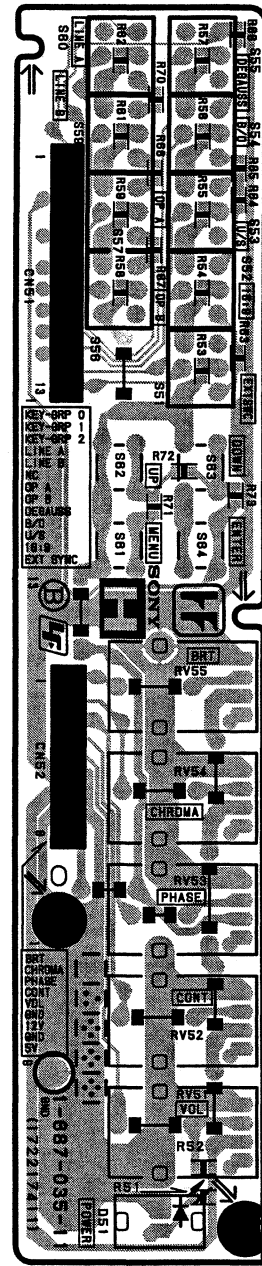

H - B SIDE-
SUFFIX: -11

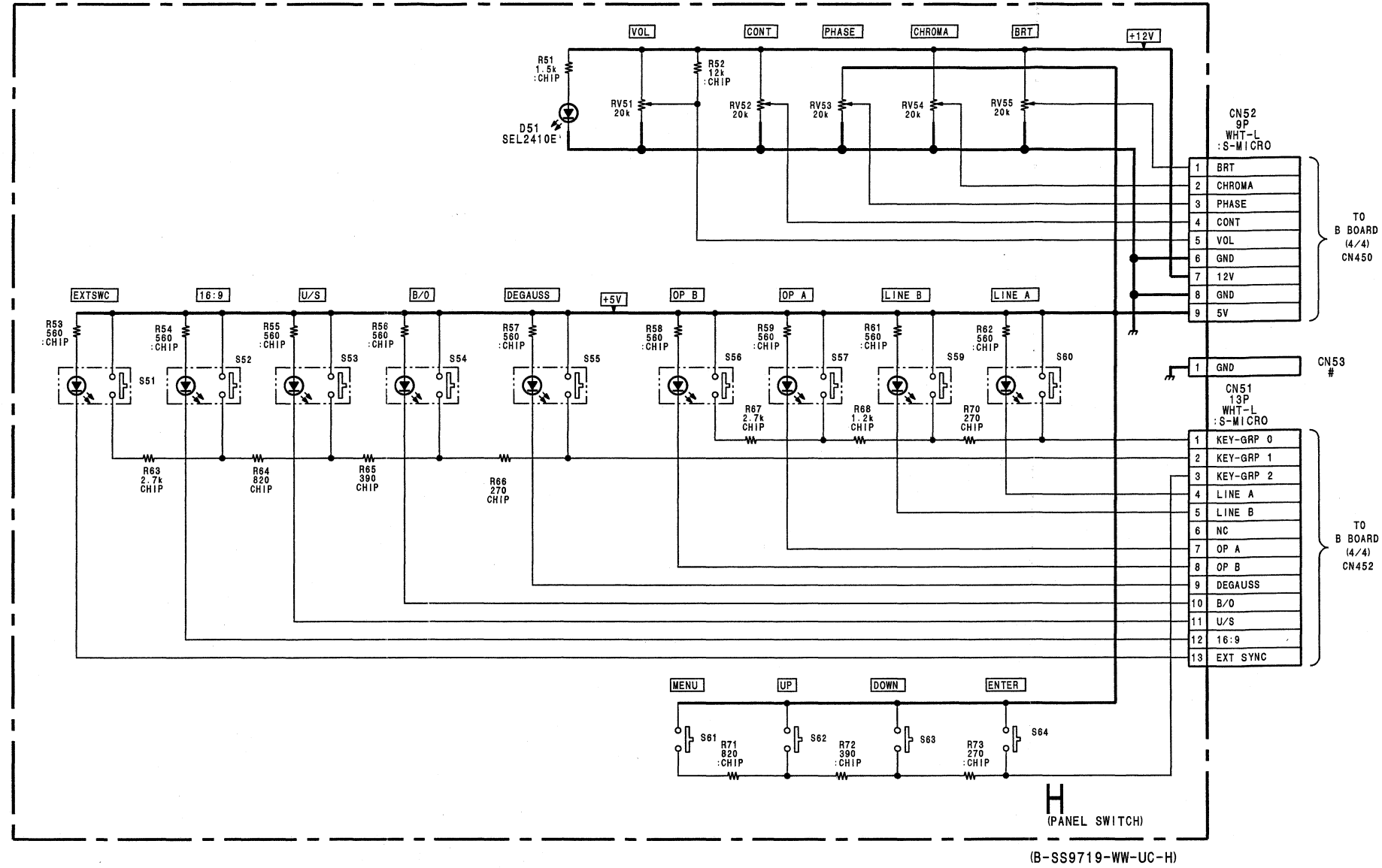

1
2
3
4
5

P BOARD

*: B SIDE

- | | |
|-------|-----|
| D802 | G-3 |
| D803 | G-2 |
| D804 | B-2 |
| D805 | A-3 |
| D806 | E-3 |
| D807 | A-3 |
| D808 | A-2 |
| D809 | A-2 |
| Q802 | C-2 |
| Q803 | B-2 |
| RV801 | A-2 |

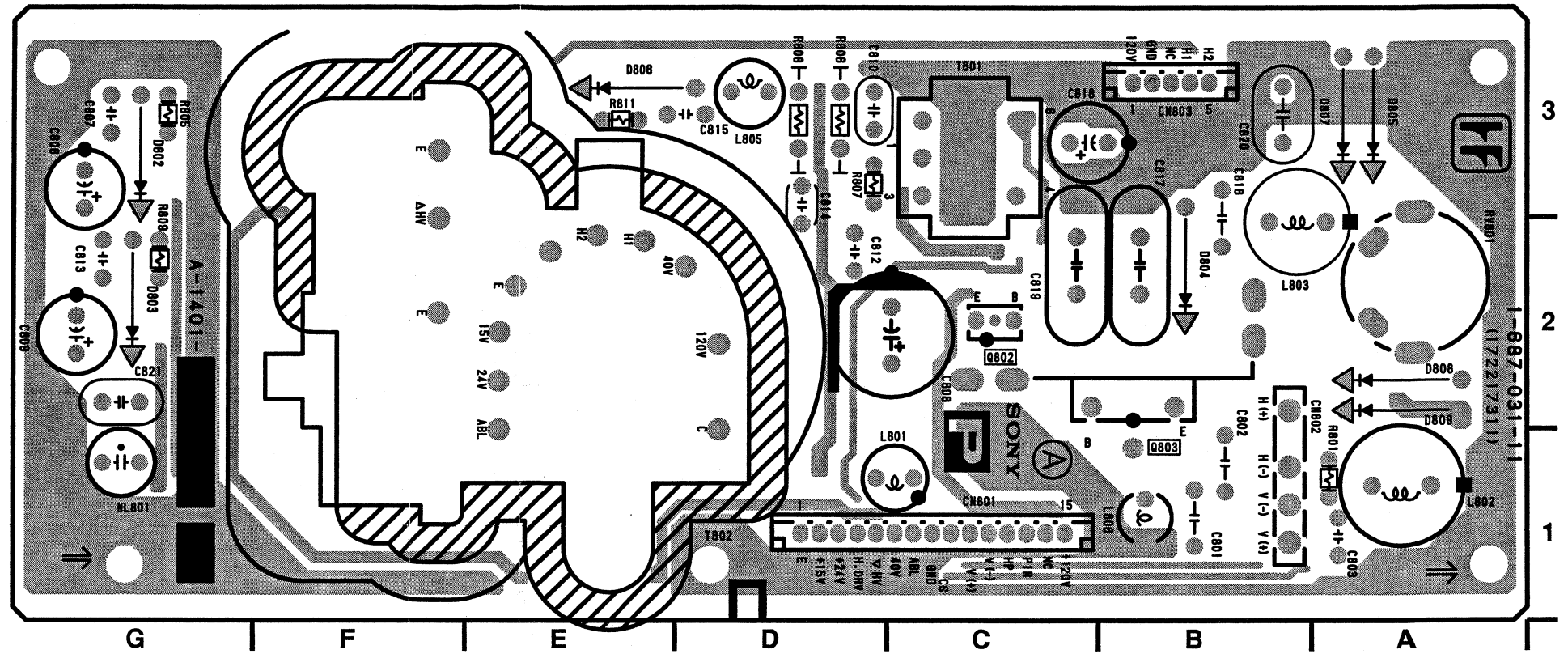

P - A SIDE-
SUFFIX: -11

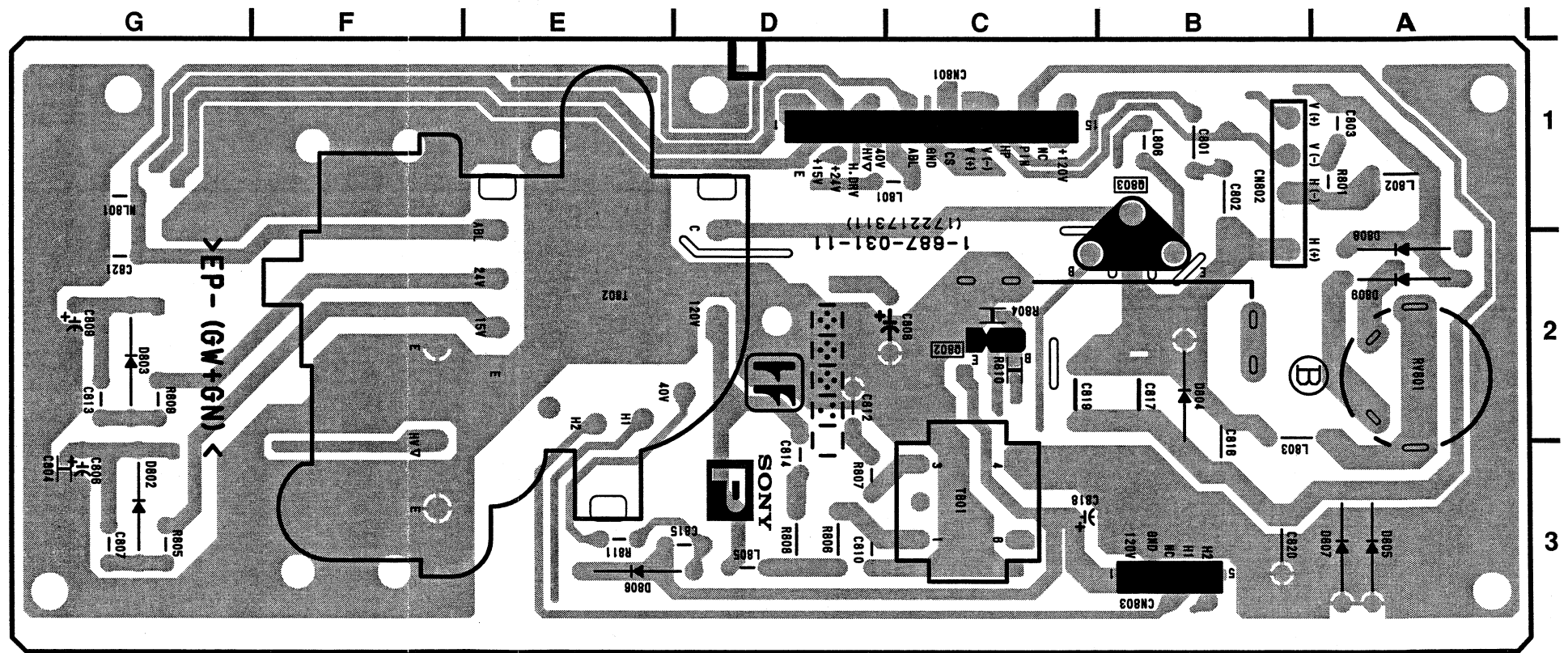

P - B SIDE-
SUFFIX: -11

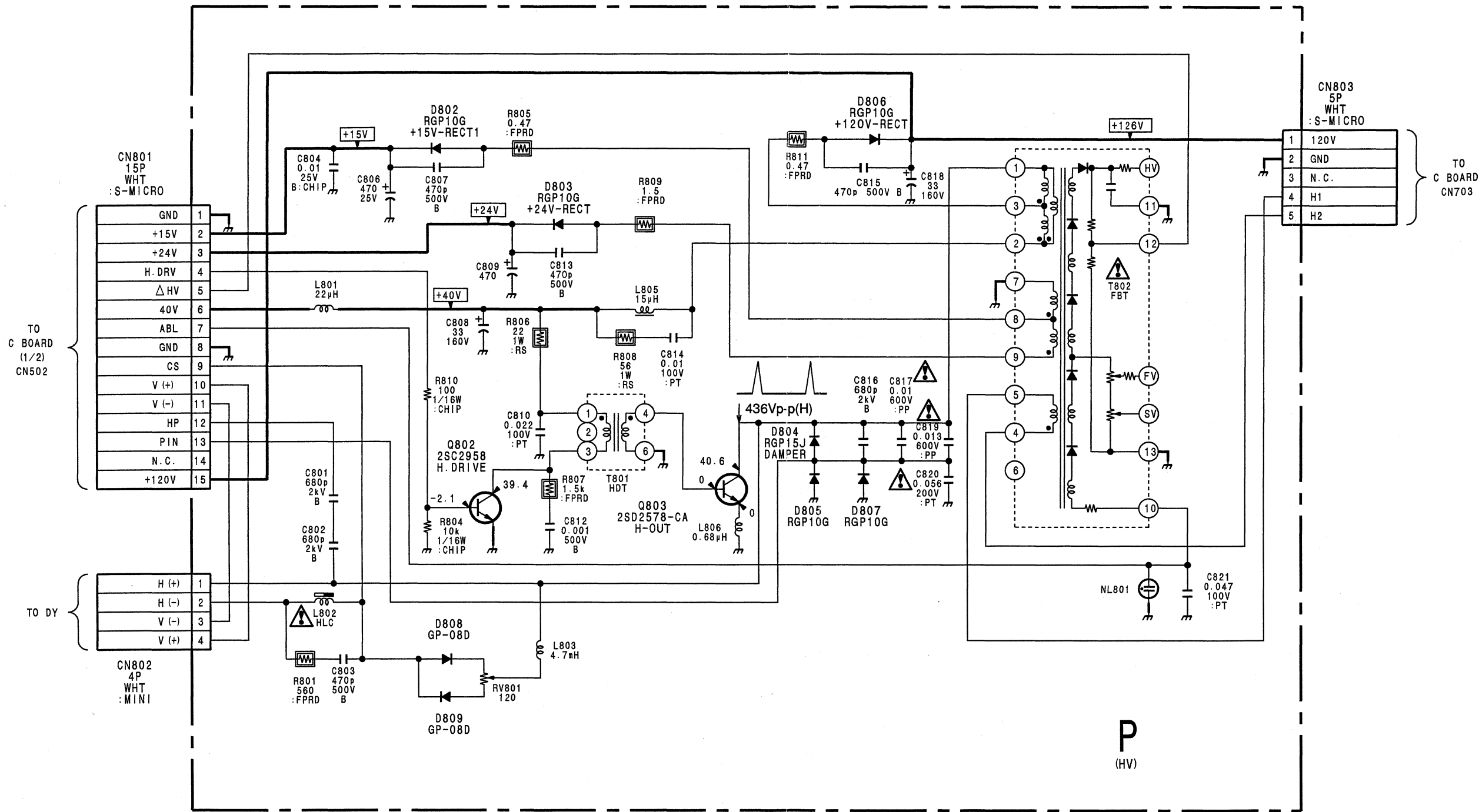

(B-SS9719-WW-UC-P)

1
2
3
4
5

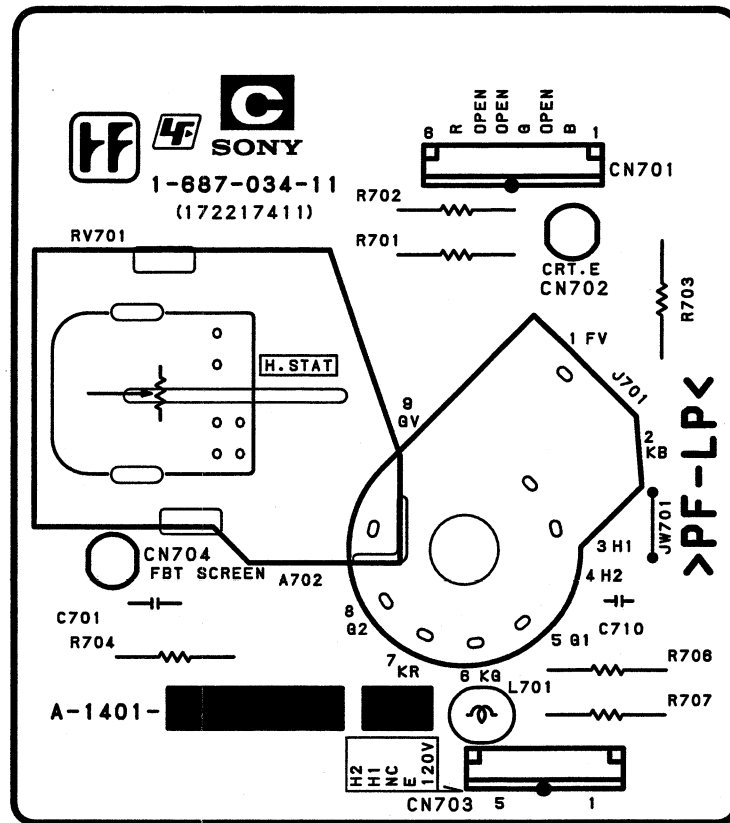

C -A SIDE-
SUFFIX: -11

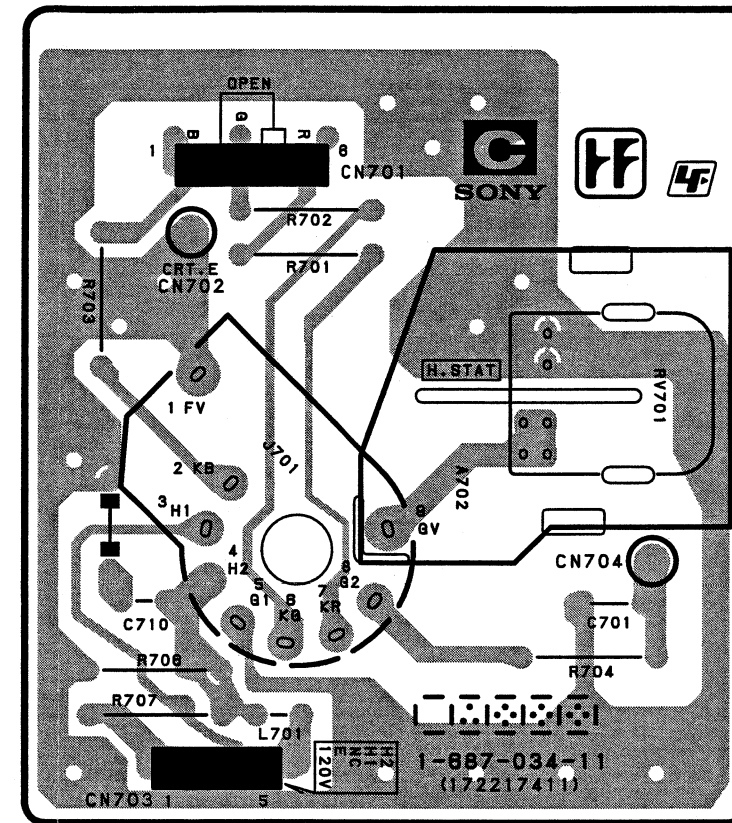

C -B SIDE-
SUFFIX: -11

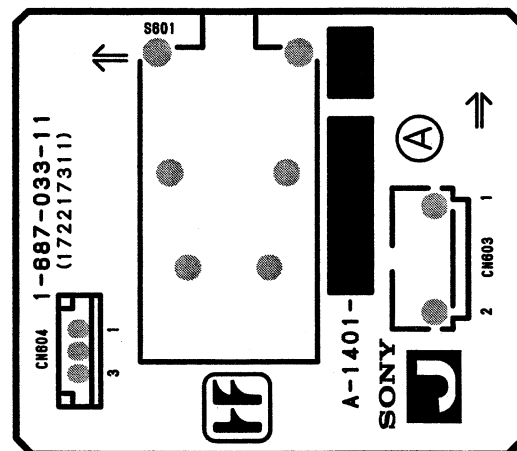

J -A SIDE-
SUFFIX: -11

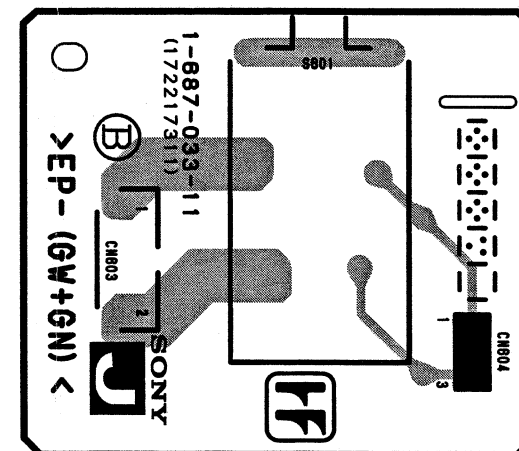

J -B SIDE-
SUFFIX: -11

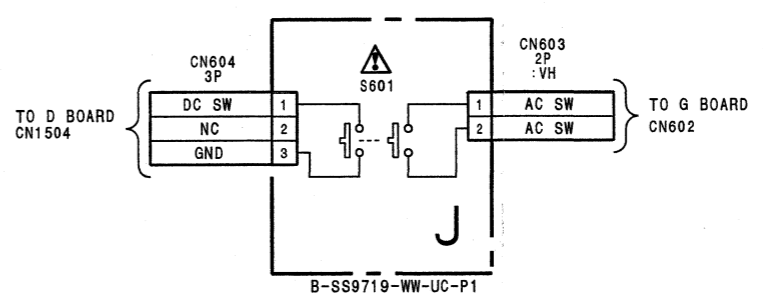
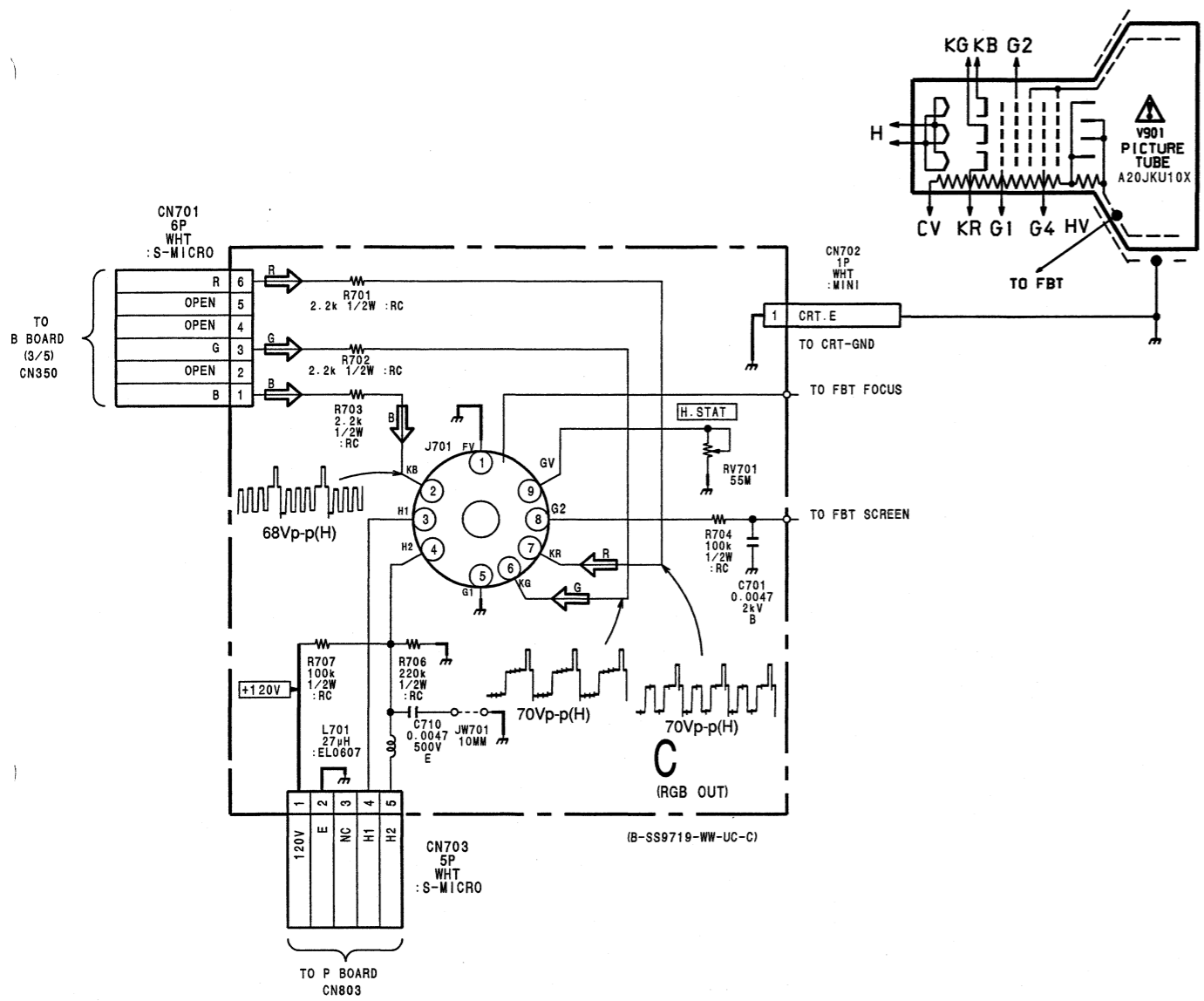

1
—
2
—
3
—
4
—
5

D BOARD

*:B SIDE

- | | | | |
|--------|-------|--------|-------|
| D501 | * G-3 | Q501 | * F-2 |
| D502 | * F-2 | Q502 | * F-2 |
| D503 | * F-2 | Q503 | * F-2 |
| D504 | * F-2 | Q504 | * F-2 |
| D505 | * B-2 | Q505 | * F-2 |
| D506 | * D-1 | Q506 | * F-2 |
| D507 | * H-3 | Q507 | * D-2 |
| D508 | * D-1 | Q508 | * A-2 |
| D509 | * H-3 | Q509 | * B-1 |
| D510 | * H-2 | Q510 | * B-2 |
| D511 | * G-1 | Q511 | * D-1 |
| D512 | * F-2 | Q512 | * H-3 |
| D513 | * F-2 | Q513 | * F-1 |
| D514 | * F-1 | Q514 | * F-2 |
| D515 | * G-2 | Q515 | * G-2 |
| D516 | * F-2 | Q516 | * G-2 |
| D517 | * H-3 | Q517 | * H-3 |
| D518 | * D-3 | Q518 | * H-3 |
| D519 | * D-4 | Q519 | * H-3 |
| D1501 | * A-2 | Q520 | * D-4 |
| D1502 | * B-2 | Q521 | * D-4 |
| D1503 | * B-2 | Q1501 | * A-3 |
| D1504 | * D-3 | Q1502 | * A-3 |
| D1505 | * A-4 | Q1503 | * A-3 |
| D1506 | * C-2 | Q1504 | * A-2 |
| D1507 | * C-3 | Q1505 | * B-2 |
| D1510 | * A-4 | Q1506 | * C-3 |
| D1511 | * A-4 | Q1507 | * A-4 |
| D1512 | * A-4 | Q1508 | * C-3 |
| D1513 | * A-4 | Q1509 | * D-3 |
| D1514 | * B-4 | Q1510 | * A-4 |
| D1515 | * C-5 | Q1511 | * A-4 |
| D1516 | * B-4 | Q1512 | * D-3 |
| D1517 | * G-4 | Q1513 | * B-3 |
| D1518 | * F-4 | Q1514 | * A-4 |
| D1519 | * E-4 | Q1515 | * A-4 |
| D1520 | * E-5 | Q1516 | * A-4 |
| D1521 | * H-5 | Q1517 | * C-4 |
| D1522 | * H-5 | Q1518 | * B-4 |
| D1523 | * H-5 | Q1519 | * B-4 |
| D1524 | * H-5 | Q1520 | * G-5 |
| D1525 | * H-5 | Q1521 | * F-4 |
| D1526 | * H-5 | Q1522 | * F-4 |
| D1527 | * H-5 | Q1523 | * F-4 |
| | | Q1524 | * E-4 |
| | | Q1525 | * E-4 |
| IC501 | * F-2 | Q1526 | * G-4 |
| IC502 | * F-3 | Q1527 | * G-4 |
| IC503 | * G-3 | Q1528 | * H-5 |
| IC504 | * F-3 | Q1529 | * H-5 |
| IC505 | * D-4 | Q1530 | * G-6 |
| IC506 | * H-2 | RV1501 | * B-4 |
| IC1501 | * C-4 | | |
| IC1503 | * D-1 | | |
| IC1504 | * E-1 | | |
| IC1506 | * C-4 | | |
| IC1507 | * G-5 | | |
| IC1508 | * E-4 | | |
| IC1509 | * F-4 | | |
| IC1510 | * H-4 | | |
| IC1511 | * H-4 | | |

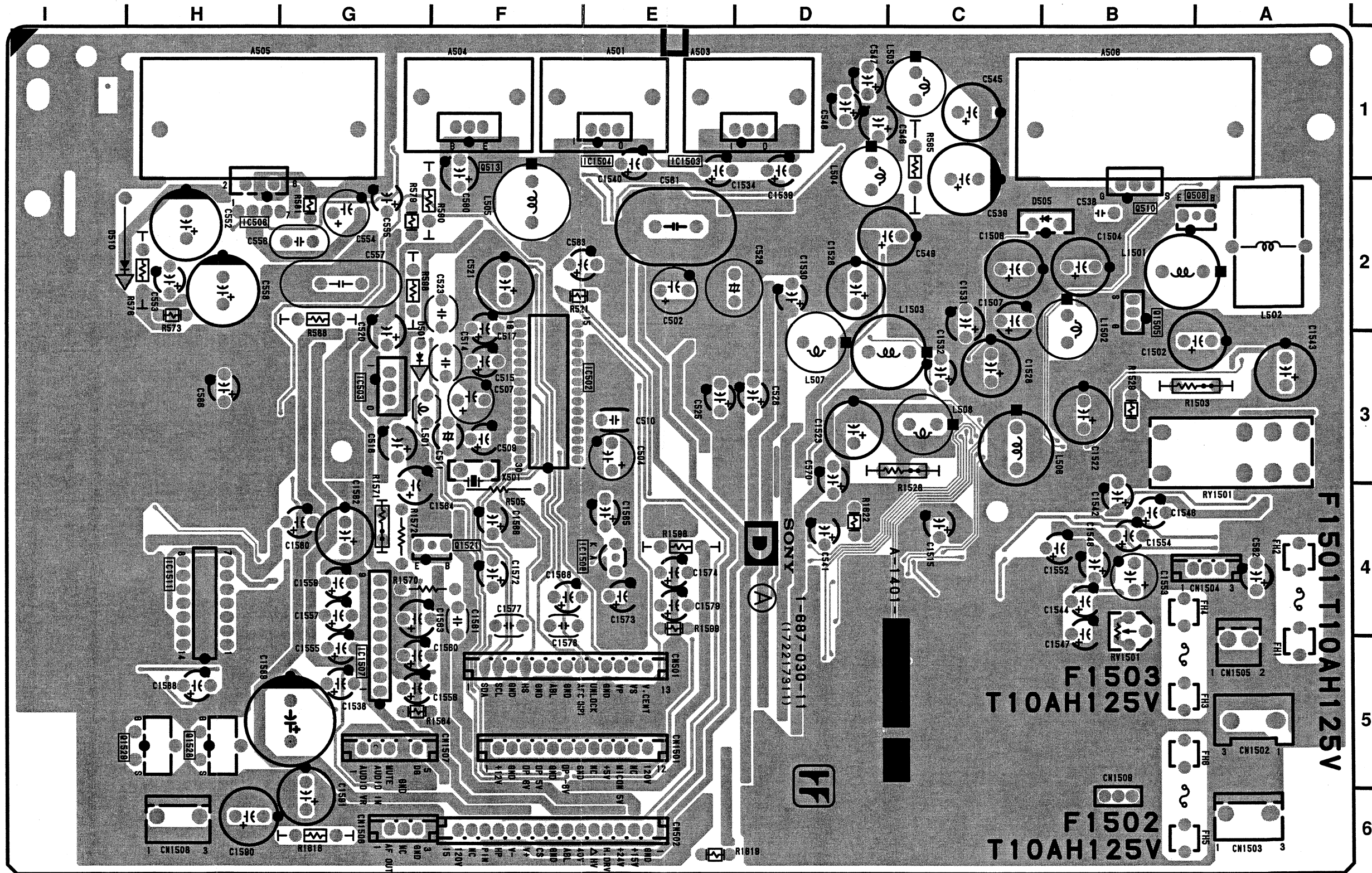

D - A SIDE-
SUFFIX: -11

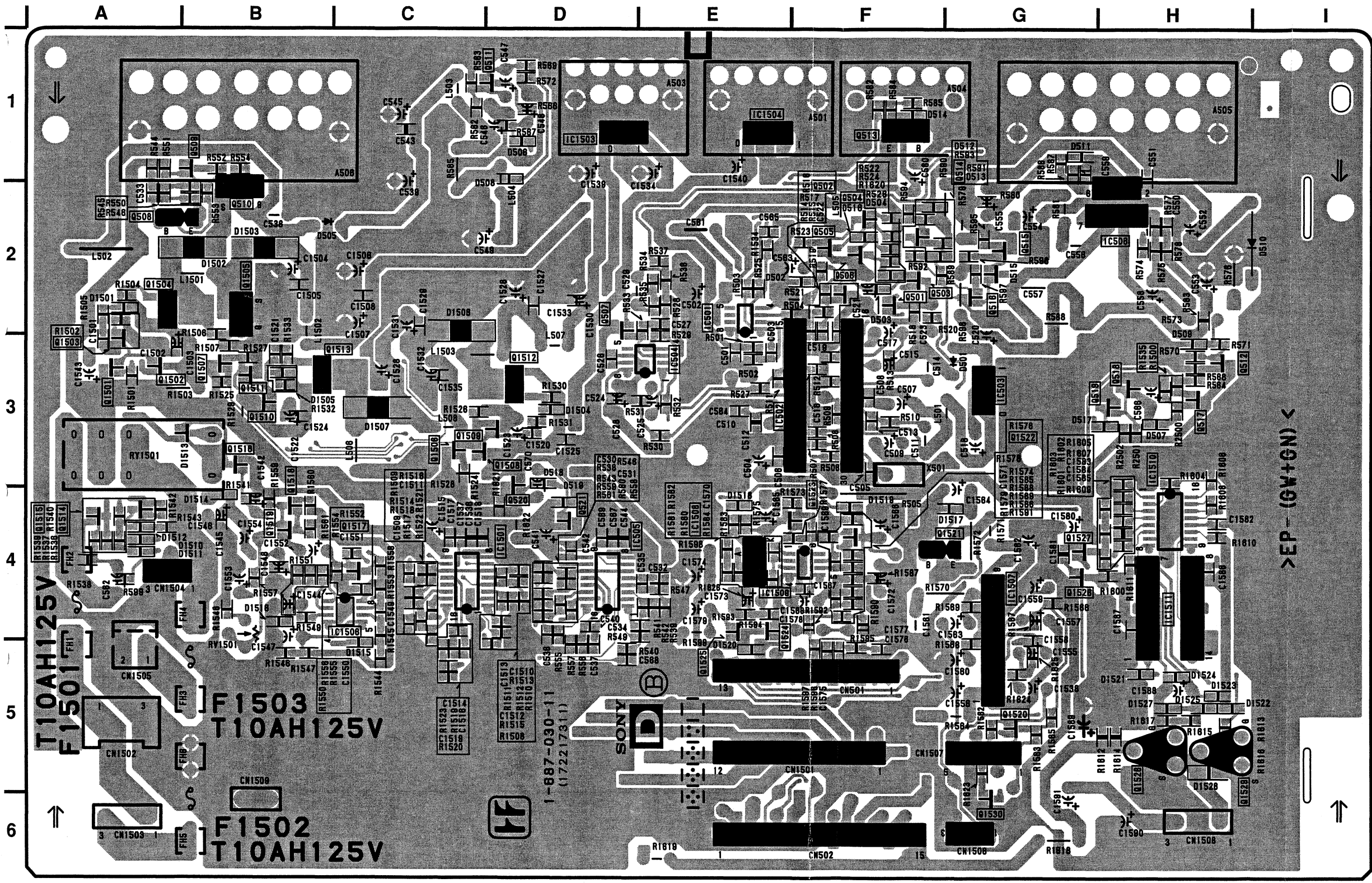

D -B SIDE-
SUFFIX: -11

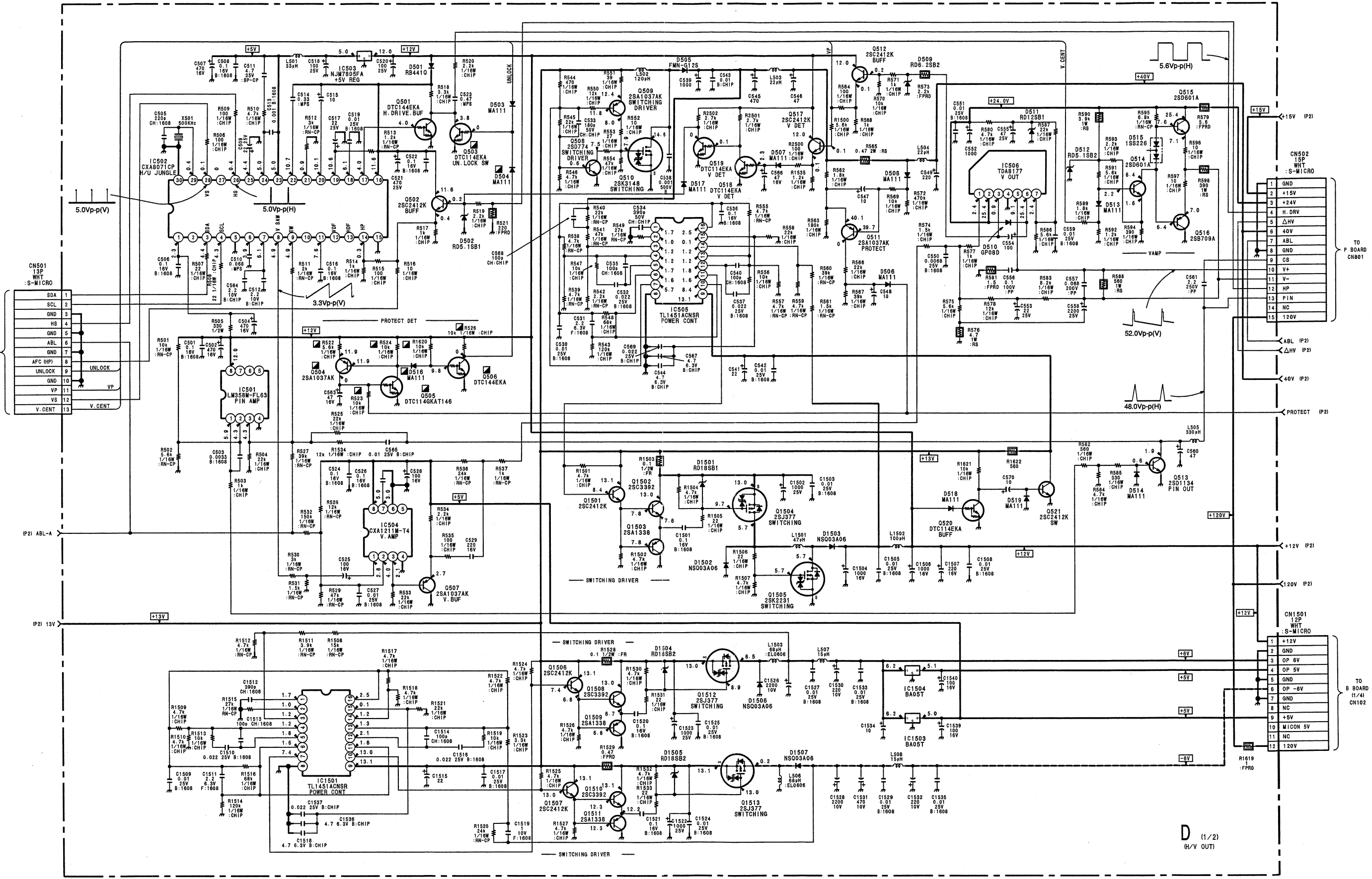

(B-SS9719-WW-UC-D-P1)

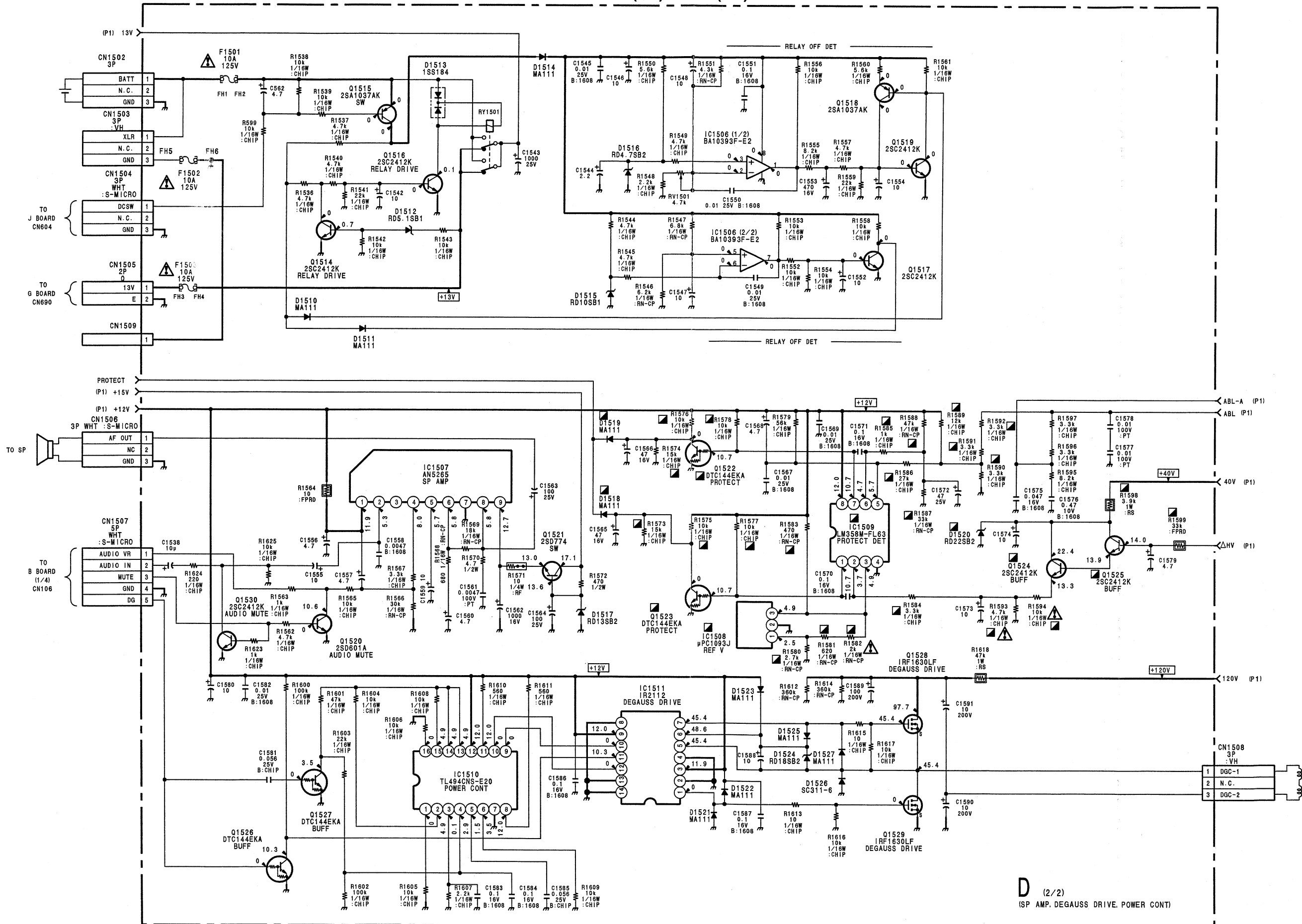

D (2/2) (SP AMP, DEGAUSS DRIVE, POWER CONT)

(B-SS9719-WW-UC-D-P2)

1

2

3

4

5

D (2/2) AN5265 (IC1507)

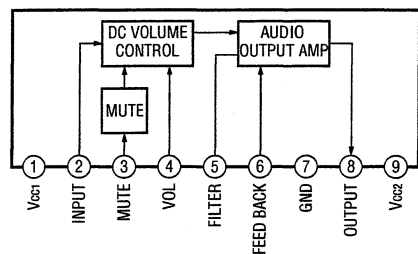

D (1/2, 2/2) LM358M-FL63 (IC501, IC1509)

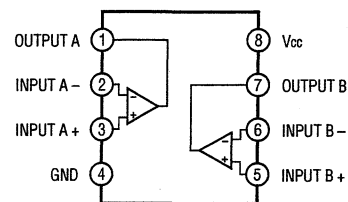

D (1/2) CXA1211M-T4 (IC504)

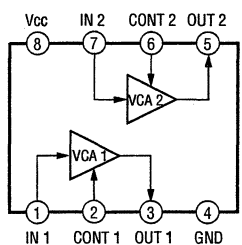

D (1/2) CXA8071CP (IC502)

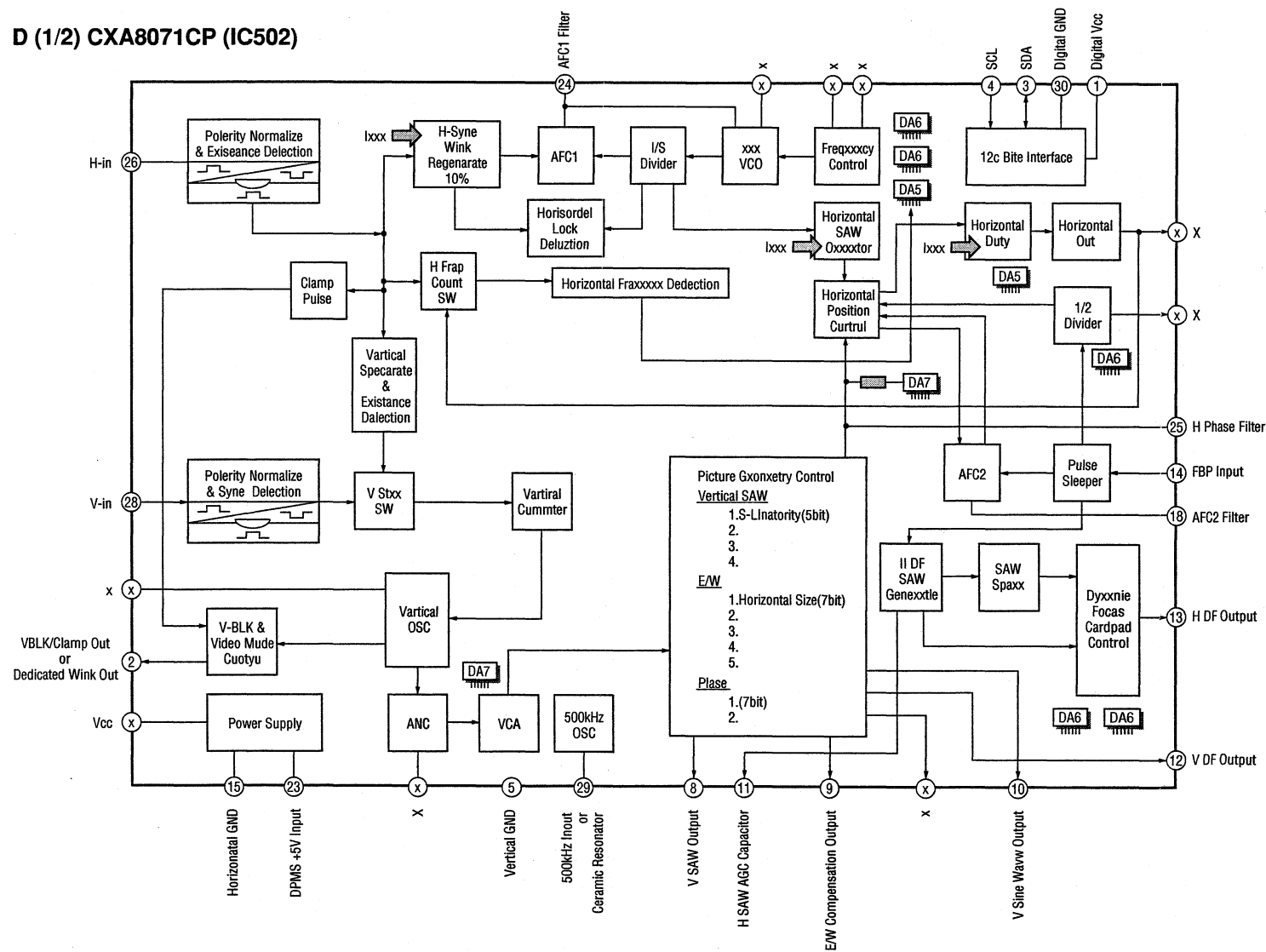

D (2/2) IR2112 (IC1511)

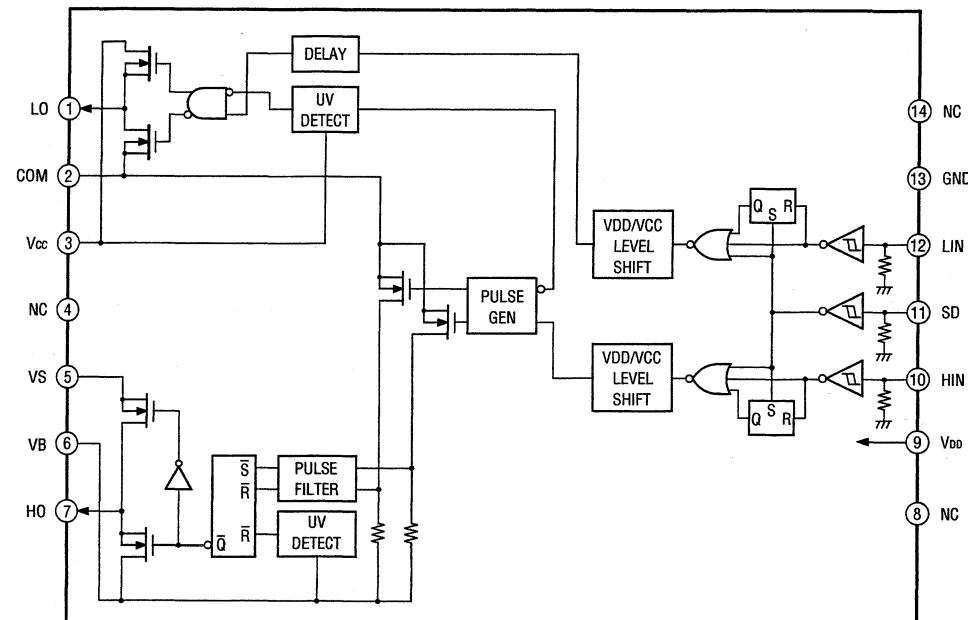

D (1/2) TDA8177 (IC506)

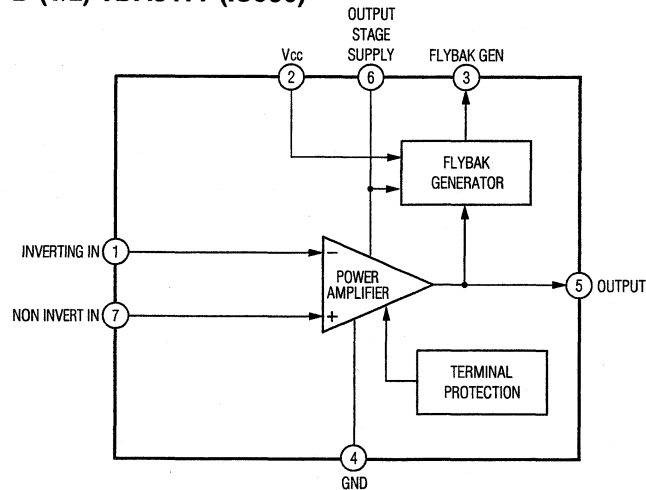

D (2/2) TL494CNS-E20 (IC1510)

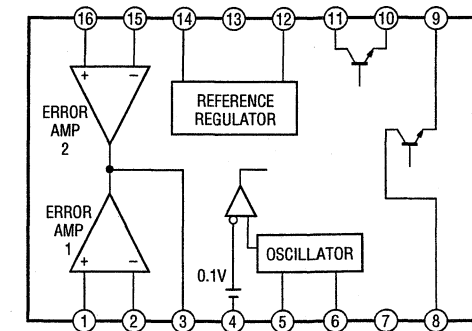

D (1/2) TL1451ACNSR (IC1501, IC1505)

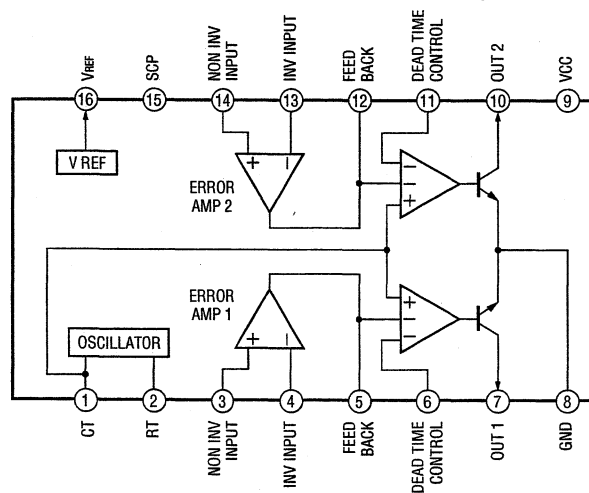

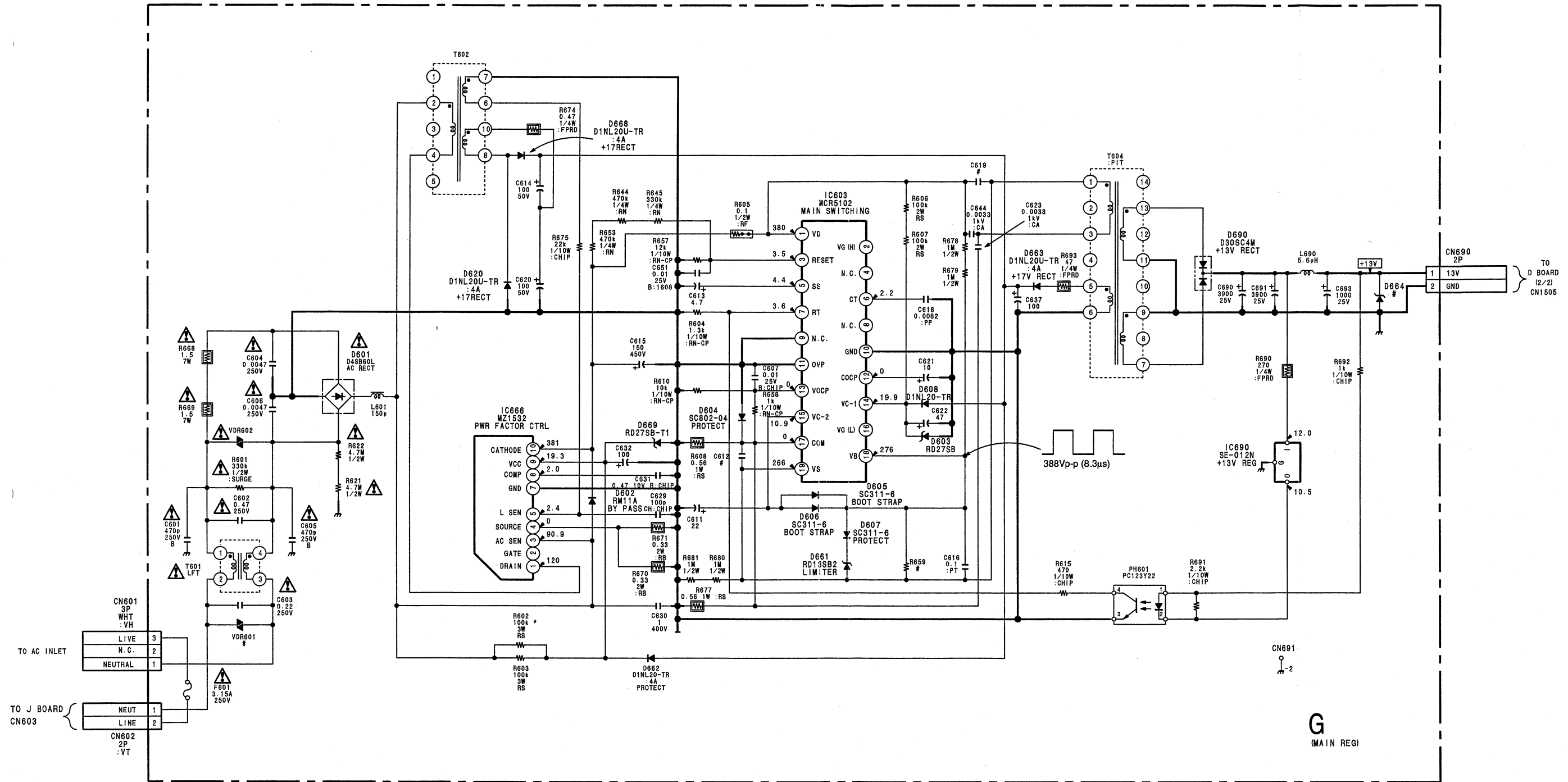

G
(MAIN REG)

(B-SS9719-WW-UC-G)

G BOARD

*:B SIDE

- D602 B-1
- D603 *D-4
- D604 *D-3
- D605 *E-4
- D606 *E-4
- D607 *E-4
- D608 C-3
- D620 C-3
- D661 *E-4
- D662 B-3
- D663 E-3
- D664 *I-3
- D668 *C-3
- D669 *A-2
- D690 H-4
- IC603 E-4
- IC666 E-1
- IC690 I-2

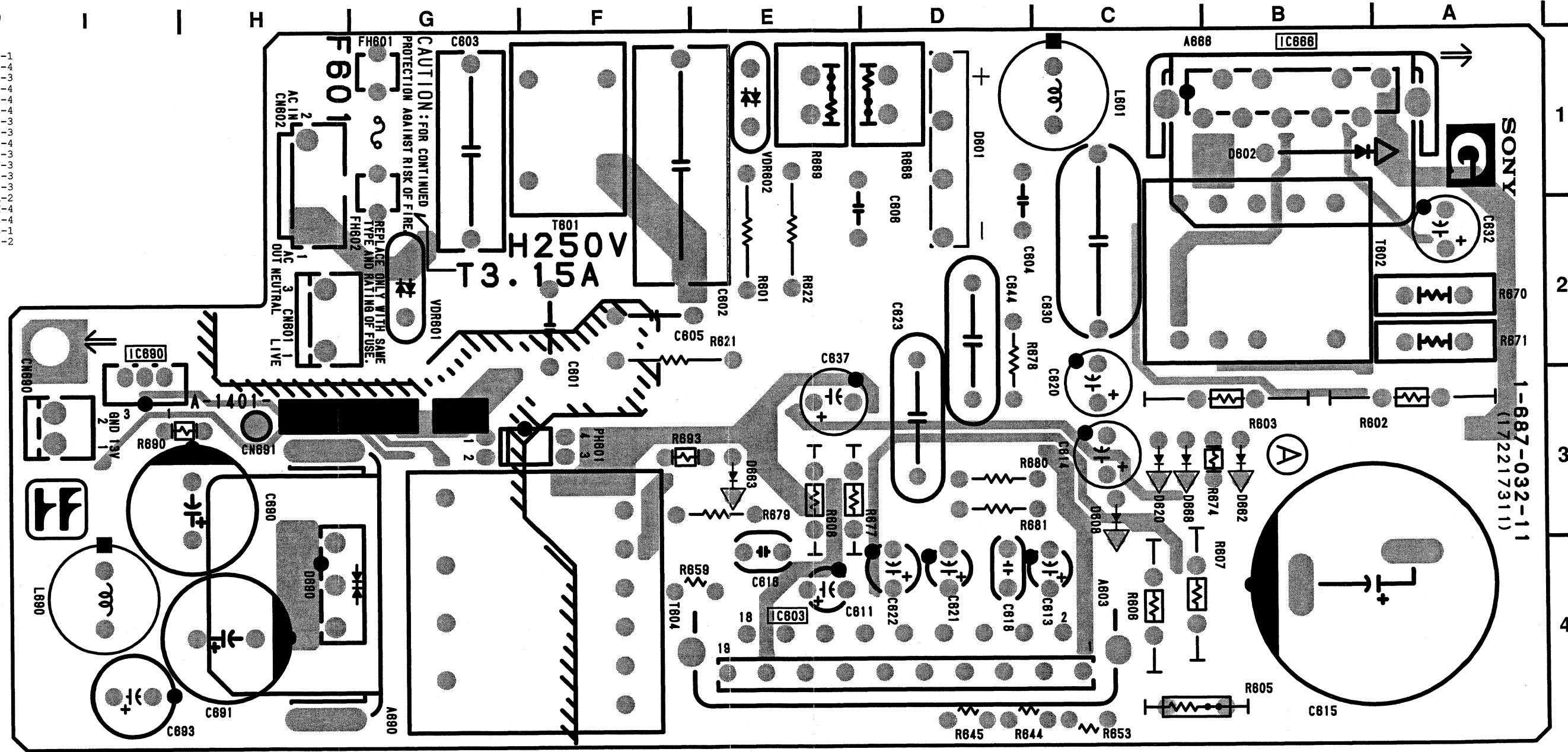

G -A SIDE-
SUFFIX: -11

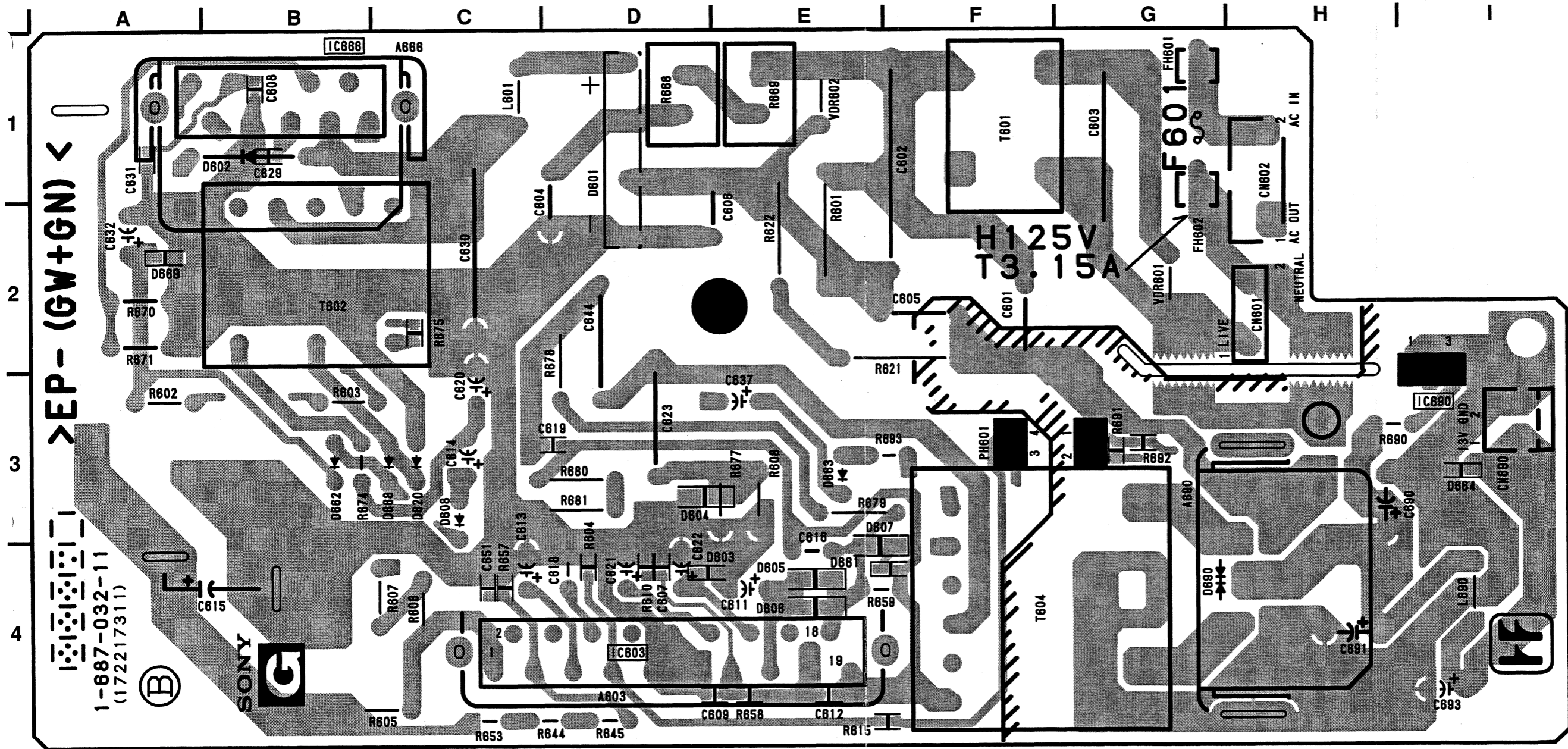

G - B SIDE-
SUFFIX: -11

G MCR5102 (IC603)

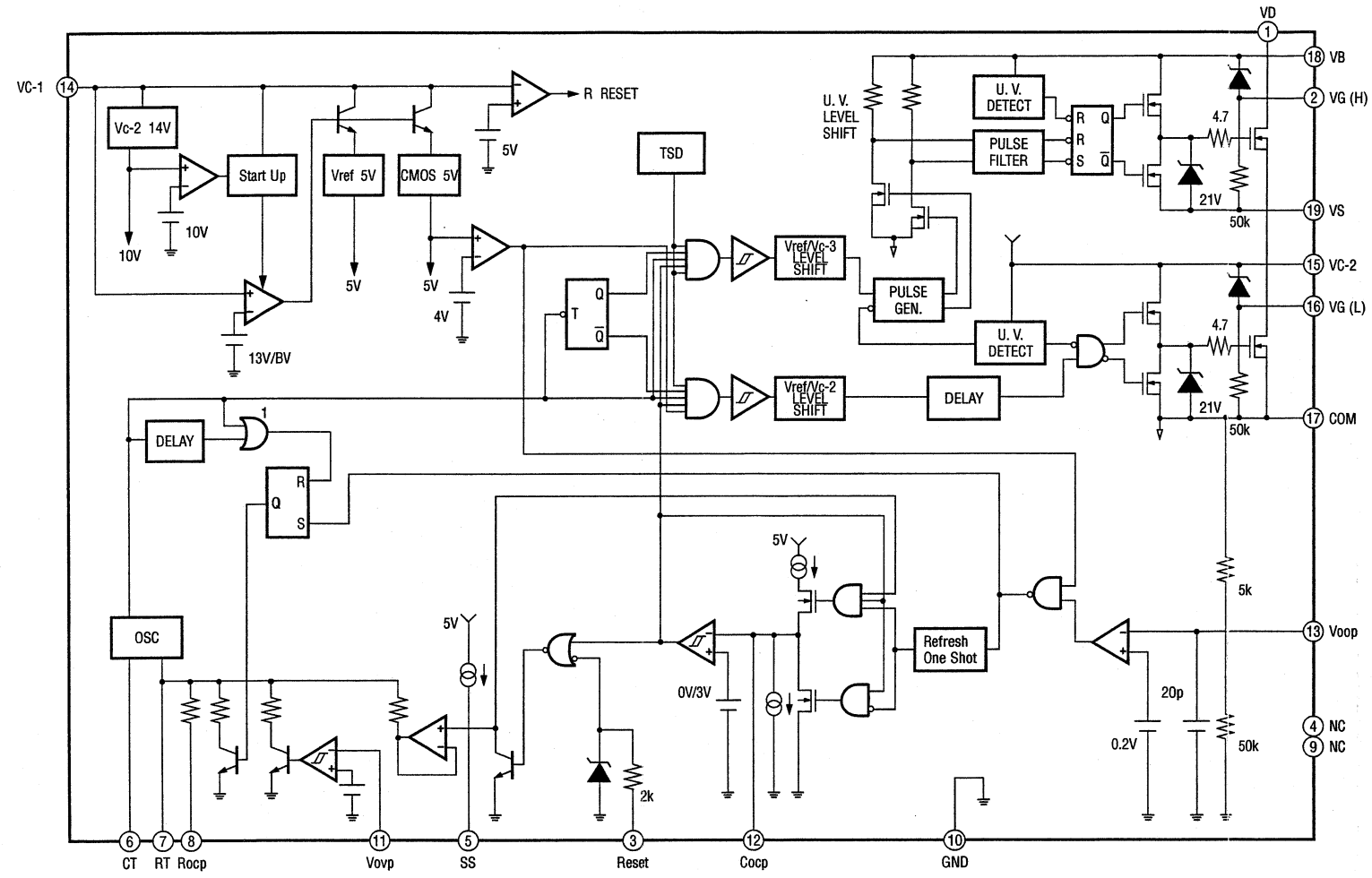

G MZ1532 (IC666)

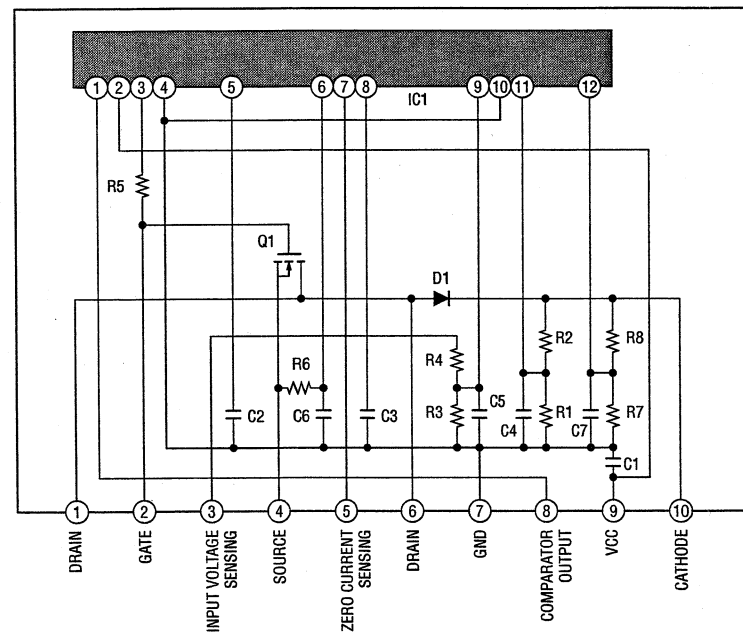

SAFETY CHECK-OUT

After correcting the original service problem, perform the following safety checks before releasing the set to the customer :

Check the metal trim, "metallized" knobs, screws, and all other exposed metal parts for AC leakage. Check leakage as described below.

LEAKAGE TEST

The AC leakage from any exposed metal part to earth ground and from all exposed metal parts to any exposed metal part having a return to chassis, must not exceed 0.5 mA. Leakage current can be measured by any one of three methods.

1. A commercial leakage tester, such as the Simpson 229 or RCA WT-540A. Follow the manufacturers' instructions to use these instruments.
2. A battery-operated AC milliammeter. The Data Precision 245 digital multimeter is suitable for this job.
3. Measuring the voltage drop across a resistor by means of a VOM or battery-operated AC voltmeter. The "limit" indication is 0.75 V, so analog meters must have an accurate low-voltage scale. The Simpson 250 and Sanwa SH-63Trd are examples of a passive VOM that is suitable. Nearly all battery operated digital multimeters that have a 2 V AC range are suitable. (See Fig. A)

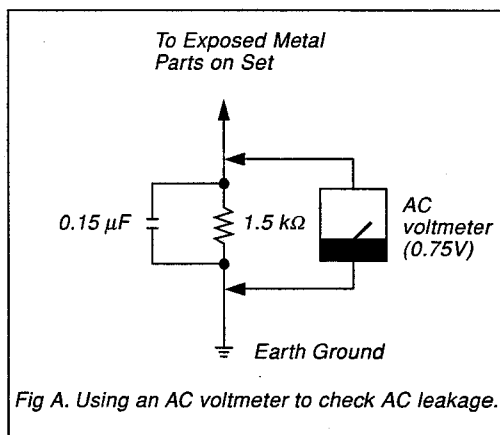

Fig A. Using an AC voltmeter to check AC leakage.